

INSTALLATION, OPERATION & SERVICE MANUAL

LOW STATIC DUCTED PDWA-EC

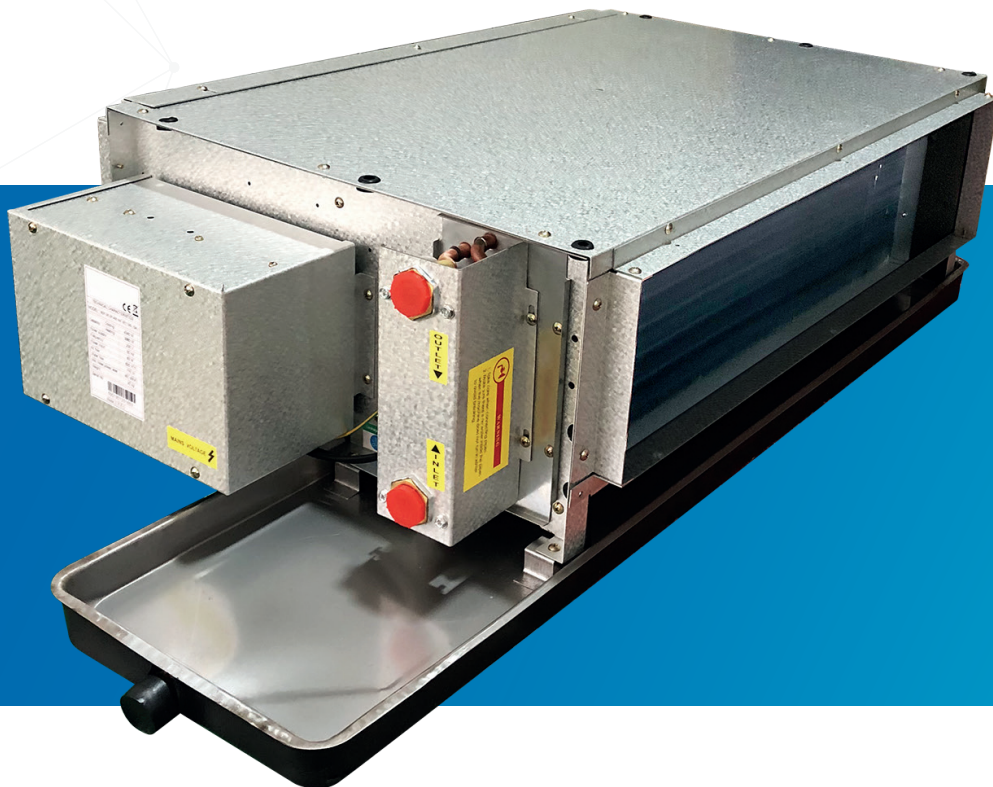

INVESTING IN QUALITY, RELIABILITY & PERFORMANCE

ISO 9001 QUALITY



Management Service

Every product is manufactured to meet the stringent requirements of the internationally recognized ISO 9001 standard for quality assurance in design, development and production.

World Leading Design and Technology

Equipped with the latest air-conditioning test rooms and manufacturing technology, we produce over 50,000 fan coil units each year, all conforming to the highest international standards of quality and safety.

CE SAFETY STANDARDS



Product Service

All products conform to the Certificate Europe directives (Machinery Safety, Electromagnetic Compatibility and Low Voltage), as required throughout the European Community, to guarantee correct standards of safety.

The Highest Standards of Manufacturing

In order to guarantee the very highest standards and performance, we manage every stage in the manufacturing of our products. Throughout the production process we maintain strict control, starting with our extensive resources in research and development through to the design and manufacture of almost every individual component, from molded plastics to the assembly of units and controllers.

EUROVENT CERTIFICATION



WEEE MARK



All products conform to the "WEEE" directive to guarantee correct standards of environmental solutions.

Quality Controlled from Start to Finish

Our highly trained staff and strict quality control methods enable us to produce products with an exceptional reputation for reliability and efficiency, maintained over many years. As well as CE certification and ISO 9001, several products ranges have UL / ETL safety approval in the USA and Canada, Eurovent performance and sound certification as well as ROHS compliance for Europe, giving you the confidence of knowing our company is the right choice when selecting fan coil units.

ALWAYS MAKE SURE THIS MANUAL REMAINS WITH THE UNIT. READ THIS MANUAL BEFORE PERFORMING ANY OPERATION ON THE UNIT.

Table of Contents

A. Technical Data	5
A.1. General Descriptions	5
A.2. General Specifications	6
A.2.1. 2-pipe Systems	6
A.2.2. 4-pipe Systems	9
A.3. Coil Data	13
A.4. Sound Power Data (Inlet + Radiated)	15
A.5. Dimensional Drawings	20
A.5.1. 2-pipe	20
A.5.2. 4-pipe	22
B. Installation	24
B.1. Safety Precautions	24
B.2. Location	25
B.3. Insulation	26
B.4. Service Connection	26
B.5. Electrical Connection	26
B.6. Unit Operation	26
C. Maintenance	27
C.1. General Maintenance	27
C.2. Regular Maintenance	27
C.3. Filter Cleaning	27
C.4. Fan Motor Assembly Maintenance	27
C.5. Coil Direction Interchange	28
C.6. Electric Heater Replacement	28
D. Control Specifications: Intelligent Control (I Type)	29
D.1. I/O Port Definitions	29
D.2. Wiring Diagram	30
D.2.1. Fan Coil Unit ON/OFF	31
D.2.2. Auto Restart	31
D.3. Control Logics for 2-Pipe System	32
D.4. Control Logics for 4-Pipe System	35
D.5. Control logic for 2-pipe with 6-way modulating valve configuration	37
D.6. Sleep Mode	39
D.7. Buzzer	39
D.8. Auto Restart	39
D.9. On/Off Switch on LED Display Panel	39
D.10. Drain Pump (Optional)	39
D.11. Float Switch	39
D.12. Electric Heater Safety Switch	40
D.13. Low Temperature Protection of Indoor Coil in Winter	40
D.14. Network Setup	41
D.15. Open Modbus Protocol	43
D.16. LED Indication and Error Description	47
E. Control Specifications: Flexible function (W Type)	48
E.1. Features	48
E.2. I/O Port Definitions	48
E.3. Onboard configuration	48
E.4. Wiring Diagram	49
E.5. Control Logic Specifications	50
E.5.1. Unit Power ON/OFF	50
E.5.2. Alarm Protection and Error Display	50
E.5.3. Drain Pump Operation	50
E.5.4. Modulating Signal Input	50
E.5.5. Electrical Heater Operation	50
E.5.6. Low Temperature Protection of Indoor Coil in Winter	50
E.6. LED Display and Error Description	51
F. User Interface	52
F.1. Remote Handset	52
F.2. Wired Wall Pad Controller	53
F.2.1. LED display	53

F.2.2. Operation guide.....	54
F.2.3. Error Code List	57
F.2.4. Dimensions and installation	58
G. Sensor Resistance R-T Conversion Table	59
H. Troubleshooting.....	61

Model Code Nomenclature

<u>1</u>	<u>2</u>	<u>3</u>	<u>4</u>	<u>5</u>	<u>6</u>	<u>7</u>
<u>PDWA</u>	<u>-3R</u>	<u>-200</u>	<u>-V</u>	<u>-I</u>	<u>-EC</u>	<u>-LS</u>

Notation		Description
1	PDWA	Low Static Hydronic Ducted Unit
2	3R	3R: 2-pipe 3 rows 4R: 2-pipe 4 rows 3+1R: 4-pipe with 3rows cooling and 1 row heating
3	200	Unit Size (See General Specification Section A for cooling and heating capacities.)
4	V	V – 2-pipe P – 4-pipe
5	I	Control type: I –Intelligent Control W – Flexible Function Control
6	EC	EC Motor
7	LS	Coil Connection : LS : Left Side RS : Right Side

A. Technical Data

A.1. General Descriptions

The Duct Fan Coil is designed to meet and exceed the demanding requirements for efficient and quiet operation.

Structure

The structure is made from heavy gauge galvanized steel panels with couplings for the connection of ducting and a gravity drain pan with insulation for condensation. Fire resistant insulation is optional for internal casing to provide both thermal and acoustic insulation. Insulation is also fitted on the top of coil.

Condensate Pans

Positive sloped drain pans are steel with powder finish, coated with self-extinguishing closed cell expanded polyethylene with thermal properties. The drain pan outlet is 3/4" (standard on the same side of coil connections).

Coils

Constructed with seamless copper tubes and headers. The tubes are mechanically expanded into corrugated aluminum fin material for permanent primary to secondary surface bond. Coils are tested at 35 bar and recommended for a maximum operation at 20 bar. Coils include manual air vent and water purge valves.

Fan Wheels

Housings are double inlet forward curved centrifugal types. Wheels are statically and dynamically balanced for smooth and quiet operation. The housings manufactured in heavy gauge galvanized steel with die-formed inlet cones.

EC motor

The unit adopts EC motor which powered by PCB. The constant torque and permanent magnet brushless EC motor with preliminary 3-speed setting allows precise air balancing.

Air filter

It is easily removable and washable and is made from self-extinguishing acrylic with an efficiency of class EU2 (G2) (Merv 2-4). G4 (Merv 8) efficiency is optional.

CONTROL SYSTEMS

1. Intelligent control (I type)

Intelligent control board is controlled via Infra-red handset and/or Intelligent wired wall pad, is field programmable and easy to be configured through the wired wall pad or open Modbus protocol with VWV and VAV control logics, provides variable speed indoor fan control, integrates with Intelligent modulating valves to allow Auto Dynamic Balancing and Intelligent Constant Delta T management systems. It controls 2-pipe, 2-pipe with electric heater, 2-pipe with 6-way valve and 4-pipe systems.

2. Flexible control (W type)

This control options features flexible functionality for external thermostat applications, allowing the independent control of drain pumps (if equipped), offering zone control operations, and limited diagnostics. In products where louvers are required, this control allows the stepping motors to open the louver at maximum position or close them when power of the unit is OFF.

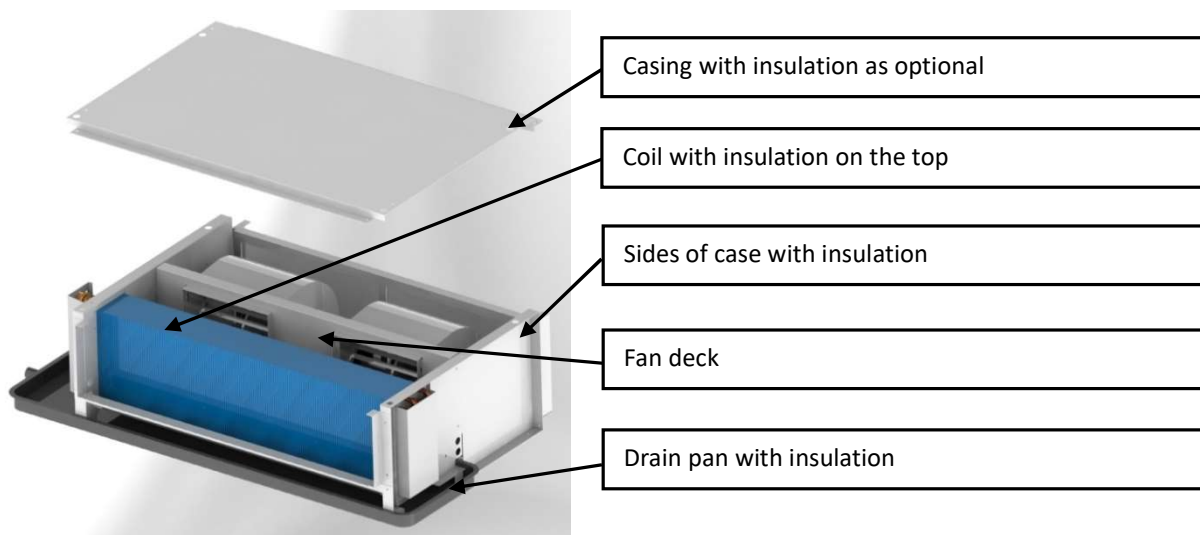



A.2. General Specifications

A.2.1. 2-pipe Systems

Product range: PDWA-3R-ECM Low Static Hydronic Ducted Fan Coil Unit

PDWA-3R-V~-ECM Hydronic Ducted 2-pipe Unit with 3-row Coil and EC motor

PDWA-3R-[Size]-V~-ECM				200	300	400B	500	600	800B	1000	1200	1400	1600	
Unit Configuration				Configuration		2-pipe								
				Number Of Fan Blowers		Single		Twin		Three		Four	Three	Four
				Power Supply (V/Ph/Hz)		220-240 / 1 / 50-60								
Performance Data	Air	Air Flow	H	m³/hr	463	574	784	913	1085	1363	1611	1915	2477	3198
			M	429	553	746	892	1051	1310	1554	1871	2374	3019	
			L	401	524	656	749	953	1146	1413	1767	2247	2912	
		Available pressure	H	Pa	58	54	59	55	62	56	52	60	60	57
			M	50	50	50	50	50	50	50	50	50	50	50
			L	35	35	30	32	39	31	35	40	43	39	
	Cooling	Cooling Capacity ^e	H	kW	2.82	3.39	4.34	5.13	5.84	8.39	8.74	10.21	13.25	15.54
			M		2.66	3.29	4.19	5.02	5.7	8.13	8.53	10.06	12.86	14.85
			L		2.52	3.17	3.79	4.43	5.3	7.35	7.95	9.67	12.27	14.4
		Sensible Cooling Capacity ^e	H	kW	2.03	2.42	3.15	3.69	4.16	5.98	6.31	7.39	9.55	11.14
			M		1.91	2.34	3.03	3.6	4.05	5.78	6.15	7.27	9.25	10.62
			L		1.8	2.25	2.72	3.14	3.74	5.18	5.7	6.95	8.77	10.25
		Latent Cooling Capacity	H	kW	0.79	0.97	1.19	1.44	1.68	2.41	2.43	2.82	3.7	4.4
			M		0.75	0.95	1.16	1.42	1.65	2.35	2.38	2.79	3.61	4.23
			L		0.72	0.92	1.07	1.29	1.56	2.17	2.25	2.72	3.5	4.15
	FCEER ^e	Rating		79.4	76.3	74.3	64.9	55.4	76.0	76.8	69.3	58.3	47.7	
		Class		B	B	B	B	C	B	B	B	C	C	
	Heating	Heating Capacity ^e	H	kW	2.43	3.04	3.98	4.67	5.52	7.13	8.23	9.52	12.2	15.3
			M		2.32	2.95	3.82	4.6	5.38	6.94	8.02	9.36	11.9	14.6
			L		2.2	2.82	3.47	3.99	5.03	6.26	7.42	8.96	11.4	14.3
		Max. Electric Heater Capacity			2	3	4	5	6	6	6	6	6	
	FCCOP ^e	Rating		70.9	69.3	71	61	52.9	65.9	73.5	66	55.4	47.3	
		Class		B	B	B	B	C	B	B	B	C	C	
	Sound	Sound Pressure Level (Outlet)		dB(A)	48/47/43	50/49/46	52/50/44	52/51/46	54/52/49	53/52/47	56/54/50	58/55/52	58/54/50	59/57/55
Sound Pressure Level (Inlet + Radiated)		50/49/45	52/51/48		54/52/46	54/53/48	56/54/51	55/54/49	58/56/52	60/57/54	60/56/52	61/59/57		
Sound Power Level (Outlet) ^e		57/56/52	59/58/55		61/59/53	61/60/55	63/61/58	62/61/56	65/63/59	67/64/61	67/63/59	68/66/64		
Sound Power Level (Inlet + Radiated) ^e		59/58/54	61/60/57		63/61/55	63/62/57	65/63/60	64/63/58	67/65/61	69/66/63	69/65/61	70/68/66		
Electrical	Fan Motor Power	H	W	53	63	95	120	137	150	180	224	363	380	
		M		43	52	85	110	112	128	140	190	286	310	
		L		26	36	35	50	89	84	85	113	170	298	
Fan Motor Running Current @ H	A		0.46	0.55	0.72	0.83	0.89	1.30	1.78	1.95	3.16	3.30		
Hydraulic	Cooling Water Flow Rate	H	L/h	493	606	776	874	993	1558	1653	1844	2255	2644	
		M		446	572	728	861	951	1405	1475	1791	2205	2507	
		L		436	538	681	760	899	1295	1313	1631	2087	2468	
	Cooling Pressure Drop ^e	H	kPa	23.6	36.47	20.51	30.04	41.16	46.3	17.45	24.15	44.88	63.92	
		M		21.42	34.68	19.30	28.9	39.41	43.94	16.75	23.52	42.65	59.2	
		L		19.84	32.5	16.27	23.4	34.82	37	14.86	22	39.38	56.14	
	Heating Water Flow Rate	H	L/h	427	542	708	795	939	1332	1544	1725	2082	2596	
		M		387	509	666	788	897	1201	1374	1672	2033	2463	
		L		380	484	623	685	853	1109	1232	1521	1929	2425	
Heating Pressure Drop ^e	H	kPa	15.4	25.5	14.8	21.6	31.6	29.8	13.3	18.1	33.4	52.9		
	M		14.2	24.1	13.8	21	30.2	28.4	12.7	17.6	31.6	49.1		
	L		12.9	22.4	11.7	16.5	27	23.8	11.1	16.3	29.4	47.2		
water content	L		0.72	0.87	1.02	1.17	1.32	1.92	2.07	2.22	2.59	2.84		
Construction and Packing Data	Water Connections	Type		Socket(Threaded Female)										
		In	mm [in]	19.05 [3/4]										
	Out													
	Condensate Drainage Connection													
	Dimensions	L	mm	755	855	955	1055	1155	1555	1655	1795	1655	2015	
		W		550								620		
H		250								300				
Net Weight	kg		17	23	24	28	31	36	43	45	51	60		

^e: Above specifications are based on declared Eurovent test data for the year of publication of this document. To confirm the most updated specifications, please visit www.eurovent-certification.com.

Eurovent Test Conditions:

a. Cooling mode:

- Return air temperature: 27C DB/ 19C WB.

- Inlet/ outlet water temperature: 7C/ 12C.

b. Heating mode:

- Return air temperature: 20C.

- Inlet/ outlet water temperature: 45C/ 40C.

Note: For I-control models only, dimension "L" adds 100 mm.

Product range: PDWA(4R)-ECM Low Static Hydronic Ducted Fan Coil Unit
 PDWA-4R-V~ECM Hydronic Ducted 2-pipe Unit with 4-row Coil and EC motor

PDWA-4R-[Size]-V~ECM				200	300	400	500	600	800	1000	1200	1400	1600		
Unit Configuration		Configuration		2-pipe											
		Number Of Fan Blowers		Single		Twin			Three		Four	Three	Four		
		Power Supply		(V/Ph/Hz)	220-240 / 1 / 50-60										
Performance Data	Air	Air Flow	H	m ³ /hr	440	594	815	924	1125	1563	1774	2020	2907	3877	
			M		349	535	685	713	963	1176	1546	1907	2756	3675	
			L		263	393	385	541	795	928	1247	1595	2009	2679	
		Available pressure	H	Pa	50	50	50	50	50	50	50	50	50	50	50
			M		50	50	50	50	50	50	50	50	50	50	
			L		50	50	50	50	50	50	50	50	50	50	
	Cooling	Cooling Capacity	H	kW	2.82	3.6	4.87	5.89	6.79	9.31	11.22	12.73	17.17	20.51	
			M		2.36	3.33	4.25	4.85	6.07	7.53	10.1	12.18	16.56	19.71	
			L		1.9	2.63	2.73	3.93	5.21	6.21	8.58	10.67	13.01	15.5	
		Sensible Cooling Capacity	H		1.97	2.51	3.4	4.97	4.77	6.52	7.84	8.88	12.19	14.57	
			M		1.63	2.32	2.95	4.02	4.23	5.19	7	8.48	11.72	13.98	
			L		1.3	1.8	1.85	3.23	3.59	4.25	5.89	7.34	9.05	10.83	
		Latent Cooling Capacity	H		0.85	1.09	1.47	0.92	2.02	2.79	3.38	3.85	4.98	5.94	
			M		0.73	1.01	1.3	0.83	1.84	2.34	3.1	3.7	4.84	5.73	
			L		0.6	0.83	0.88	0.7	1.62	1.96	2.69	3.33	3.96	4.67	
	Sound	Sound Pressure Level (Outlet)		dB(A)	48/47/43	50/49/46	52/50/44	52/51/46	54/52/49	53/52/47	56/54/50	58/55/52	58/54/50	59/57/55	
		Sound Pressure Level (Inlet + Radiated)			50/49/45	52/51/48	54/52/46	54/53/48	56/54/51	55/54/49	58/56/52	60/57/54	60/56/52	61/59/57	
		Sound Power Level (Outlet) ^e			57/56/52	59/58/55	61/59/53	61/60/55	63/61/58	62/61/56	65/63/59	67/64/61	67/63/59	68/66/64	
		Sound Power Level (Inlet + Radiated)			59/58/54	61/60/57	63/61/55	63/62/57	65/63/60	64/63/58	67/65/61	69/66/63	69/65/61	70/68/66	
	Electrical	Fan Motor Power	H	W	53	63	83	96	102	150	205	224	363	380	
			M		43	52	58	68	84	128	174	190	286	310	
			L		26	31	35	49	62	84	121	113	170	190	
		Fan Motor Running Current @ H		A	0.46	0.55	0.72	0.83	0.89	1.30	1.78	1.95	3.16	3.30	
	Hydraulic	Cooling Water Flow Rate	H	L/h	483	617	834	1010	1164	1596	1924	2183	2944	3516	
M			404		570	729	831	1041	1290	1732	2088	2839	3379		
L			326		451	469	674	893	1065	1472	1830	2230	2656		
Cooling Pressure Drop ^e		H	kPa	43.43	74.47	139.79	70.35	97.84	102.23	148.96	196.94	130.06	192.49		
		M		31.53	64.62	109.56	49.46	79.92	69.74	123.25	181.81	121.79	179.15		
		L		21.4	42.35	49.5	33.91	60.73	49.4	91.94	143.4	78.85	116.19		
Water content		L	0.96	1.16	1.36	1.56	1.76	2.56	2.76	2.96	3.45	3.79			
Construction and Packing Data	Water Connections	Type		Socket(Threaded Female)											
		In	mm [in]	19.05 [3/4]											
		Out													
	Condensate Drainage Connection		19.05 [3/4]												
	Dimensions	L	mm	755	855	955	1055	1155	1555	1655	1795	1655	1915		
		W		550							620				
		H		250							300				
Net Weight		kg	17	23	24	28	31	36	43	45	51	60			

Test Conditions:

a. Cooling mode:

- Return air temperature: 27C DB/ 19C WB.

- Inlet/ outlet water temperature: 7C/ 12C.

Note: For I-control models only, dimension "L" adds 100 mm.

Product range: PDWA(6R)-ECM Low Static Hydronic Ducted Fan Coil Unit**PDWA-6R-V~ECM Hydronic Ducted 2-pipe Unit with 6-row Coil and EC motor**

PDWA-6R-[Size]-V~ECM			200	300	400	500	600	800	1000	1200	1400	1600		
Unit Configuration	Configuration		2-pipe											
	Number Of Fan Blowers		Single		Twin			Three		Four	Three	Four		
	Power Supply	(V/Ph/Hz)	220-240 / 1 / 50-60											
Performance Data	Air	Air Flow	H	380	532	717	822	1013	1375	1626	1860	2708	3611	
			M	294	482	599	612	869	1005	1422	1773	2591	3454	
			L	225	357	317	475	731	817	1166	1498	1897	2529	
		Available pressure	H	50	50	50	50	50	50	50	50	50	50	50
			M	50	50	50	50	50	50	50	50	50	50	50
			L	50	50	50	50	50	50	50	50	50	50	50
	Cooling	Cooling Capacity	H	2.78	3.89	5.09	5.98	7.16	9.97	11.73	13.35	18.52	23.58	
			M	2.3	3.64	4.46	4.76	6.38	7.86	10.6	12.9	17.89	22.81	
			L	1.85	2.88	2.73	3.91	5.61	6.66	9.1	11.26	14.15	17.95	
		Sensible Cooling Capacity	H	1.91	2.66	3.5	4.09	4.92	6.81	8.01	9.11	12.74	16.44	
			M	1.55	2.47	3.02	3.21	4.34	5.28	7.18	8.77	12.28	15.88	
			L	1.24	1.93	1.8	2.61	3.8	4.45	6.12	7.61	9.54	12.28	
		Latent Cooling Capacity	H	0.87	1.23	1.59	1.89	2.24	3.16	3.72	4.24	5.78	7.14	
			M	0.75	1.17	1.44	1.55	2.04	2.58	3.42	4.13	5.61	6.93	
			L	0.61	0.95	0.93	1.3	1.81	2.21	2.98	3.65	4.61	5.67	
	Sound	Sound Pressure Level (Outlet)		48/47/43	50/49/46	52/50/44	52/51/46	54/52/49	53/52/47	56/54/50	58/55/52	58/54/50	59/57/55	
		Sound Pressure Level (Inlet + Radiated)		50/49/45	52/51/48	54/52/46	54/53/48	56/54/51	55/54/49	58/56/52	60/57/54	60/56/52	61/59/57	
		Sound Power Level (Outlet)		57/56/52	59/58/55	61/59/53	61/60/55	63/61/58	62/61/56	65/63/59	67/64/61	67/63/59	68/66/64	
		Sound Power Level (Inlet + Radiated)		59/58/54	61/60/57	63/61/55	63/62/57	65/63/60	64/63/58	67/65/61	69/66/63	69/65/61	70/68/66	
		Electrical	Fan Motor Power	H	40	60	60	82	105	136	189	224	322	436
	M			24	40	40	56	82	95	133	165	193	265	
	L			17	24	31	38	55	73	77	87	127	143	
	Fan Motor Running Current @ H		A	0.46	0.55	0.72	0.83	0.89	1.3	1.57	1.95	3.16	3.3	
	Hydraulic	Cooling Water Flow Rate	H	477	668	873	1025	1227	1709	2010	2289	3175	4043	
M			394	623	764	816	1093	1348	1817	2211	3067	3910		
L			318	493	469	670	961	1142	1559	1930	2425	3078		
Cooling Pressure Drop		H	64.97	129.3	75.36	108.61	73.65	173.05	132.61	175.85	224.34	168.31		
		M	46	114.32	59.29	71.99	59.86	112.82	110.55	165.3	210.71	158.49		
		L	31.21	74.94	24.58	50.45	47.48	83.76	83.95	129.45	138.09	103.01		
Water content		L	0.96	1.16	1.36	1.56	1.76	2.56	2.76	2.96	3.45	3.79		
Construction and Packing Data	Water Connections	Type	Socket(Threaded Female)											
		In Out	mm [in]	19.05 [3/4]										
	Condensate Drainage Connection													
	Dimensions	L	755	855	955	1055	1155	1555	1655	1795	1655	1915		
		W	590								660			
		H	250								300			
Net Weight		kg	17	23	24	28	31	36	43	45	51	60		

Note:

a. Cooling mode:

- Return air temperature: 27C DB/ 19C WB.

- Inlet/ outlet water temperature: 7C/ 12C.

Note: For I-control models only, dimension "L" adds 100 mm.

A.2.2. 4-pipe Systems

Product range: PDWA-3R+1-ECM Low Static Hydronic Ducted Fan Coil Unit

PDWA-3R+1-P~-ECM Hydronic Ducted 4-pipe Unit with 3-row Cooling and 1-row Heating Coils and EC motor

PDWA-3R+1-[Size]-P~-ECM			200	300	400	500	600	800	1000	1200	1400	1600			
Unit Configuration	Configuration		4-pipe												
	Number Of Fan Blowers		Single			Twin			Three		Four	Three	Four		
	Power Supply (V/Ph/Hz)		220-240 / 1 / 50-60												
Performance Data	Air	Air Flow	H	m ³ /hr	440	594	815	924	1125	1563	1774	2020	2907	3877	
			M	349	535	685	713	963	1176	1546	1907	2756	3675		
			L	263	393	385	541	795	928	1247	1595	2009	2679		
		Available pressure	H	Pa	50	50	50	50	50	50	50	50	50	50	50
			M	50	50	50	50	50	50	50	50	50	50	50	
			L	50	50	50	50	50	50	50	50	50	50	50	
	Cooling	Cooling Capacity ^e	H	kW	2.51	3.31	4.27	4.91	5.69	8.63	8.96	10.15	14.26	17.08	
			M		2.09	3.05	3.74	4.02	5.08	6.92	8.04	9.7	13.62	16.39	
			L		1.67	2.41	2.4	3.24	4.38	5.78	6.84	8.49	10.69	12.9	
		Sensible Cooling Capacity ^e	H		1.8	2.37	3.1	3.53	4.06	6.18	6.52	7.36	10.33	12.34	
			M		1.48	2.17	2.7	2.84	3.59	4.87	5.79	7.02	9.84	11.8	
			L		1.17	1.69	1.68	2.27	3.08	4.05	4.88	6.07	7.59	9.14	
	Heating	Heating Capacity ^e	H	kW	1.91	2.52	3.35	3.78	4.47	6.37	7.12	7.98	10.64	13.56	
			M		1.61	2.34	2.93	3.11	3.95	5.13	6.42	7.65	10.26	13.1	
			L		1.29	1.83	1.87	2.52	3.43	4.28	5.42	6.61	8.03	10.25	
	Max. Electric Heater Capacity				2	3	4	5	6	6	6	6	6		
	Sound	Sound Pressure Level (Outlet)			dB(A)	48/47/43	50/49/46	52/50/44	52/51/46	54/52/49	53/52/47	56/54/50	58/55/52	58/54/50	59/57/55
		Sound Pressure Level (Inlet + Radiated)				50/49/45	52/51/48	54/52/46	54/53/48	56/54/51	55/54/49	58/56/52	60/57/54	60/56/52	61/59/57
Sound Power Level (Outlet) ^e		57/56/52	59/58/55	61/59/53		61/60/55	63/61/58	62/61/56	65/63/59	67/64/61	67/63/59	68/66/64			
Sound Power Level (Inlet + Radiated)		59/58/54	61/60/57	63/61/55		63/62/57	65/63/60	64/63/58	67/65/61	69/66/63	69/65/61	70/68/66			
Electrical	Fan Motor Power	H	W	53	63	83	96	102	150	205	224	363	380		
		M		43	52	58	68	84	128	174	190	286	310		
		L		26	31	35	49	62	84	121	113	170	190		
Fan Motor Running Current @ H		A	0.46	0.55	0.72	0.83	0.89	1.30	1.78	1.95	3.16	3.30			
Hydraulic	Cooling Water Flow Rate	H	L/h	430	568	732	842	975	1480	1536	1740	2444	2927		
		M		359	524	642	689	871	1186	1378	1663	2334	2809		
		L		287	413	411	555	750	992	1172	1456	1833	2211		
	Cooling Pressure Drop ^e	H	kPa	26.5	48.24	27.53	38.18	53.42	66.82	24.95	32.72	70.16	104.35		
		M		19.1	41.68	21.73	26.58	43.59	44.9	20.52	30.19	64.58	96.88		
		L		12.78	27.25	9.73	17.99	33.34	32.51	15.33	23.75	41.8	62.97		
	Heating Water Flow Rate	H	L/h	164	216	287	324	383	546	611	684	912	1163		
		M		138	200	251	266	339	440	551	656	879	1123		
		L		111	157	160	216	294	367	464	566	688	878		
	Heating Pressure Drop ^e	H	kPa	7.83	14.48	26.85	36.65	7.79	19.59	25.46	33.13	5.08	8.46		
M		5.72		12.65	21.08	25.71	6.23	13.27	21.13	30.69	4.76	7.95			
L		3.85		8.17	9.36	17.57	4.83	9.56	15.55	23.58	3.06	5.1			
Cooling water content		L	0.72	0.87	1.02	1.17	1.32	1.92	2.07	2.22	2.59	2.84			
Heating water content			0.24	0.29	0.34	0.39	0.44	0.64	0.69	0.74	0.86	0.95			
Construction and Packing Data	Water Connections	Type	Socket(Threaded Female)												
		In	mm [in]	19.05 [3/4]											
		Out													
	Condensate Drainage Connection														
	Dimensions	L	mm	755	855	955	1055	1155	1555	1655	1795	1655	1915		
W		550								620					
H		250								300					
Net Weight		kg	17	23	24	28	31	36	43	45	51	60			

Test Conditions:

a. Cooling mode:

- Return air temperature: 27C DB/ 19C WB.

- Inlet/ outlet water temperature: 7C/ 12C.

b. Heating mode:

- Return air temperature: 20C.

- Inlet/ outlet water temperature: 65C/55C.

Note: For I-control models only, dimension "L" adds 100 mm.

Product range: PDWA-3R+2-ECM Low Static Hydronic Ducted Fan Coil Unit

PDWA-3R+2-P~ECM Hydronic Ducted 4-pipe Unit with 3-row Cooling and 2-row Heating Coils and EC motor

PDWA-3R+2-[Size]-P~ECM				200	300	400	500	600	800	1000	1200	1400	1600		
Unit Configuration		Configuration		4-pipe											
		Number Of Fan Blowers		Single		Twin		Three		Four	Three	Four			
		Power Supply (V/Ph/Hz)		220-240 / 1 / 50-60											
Performance Data	Air	Air Flow	H	m ³ /hr	408	561	762	869	1065	1462	1694	1934	2800	3734	
			M	322	509	642	663	916	1091	1484	1840	2674	3565		
			L	244	375	351	508	763	873	1207	1547	1953	2604		
		Available pressure	H	Pa	50	50	50	50	50	50	50	50	50	50	50
			M	50	50	50	50	50	50	50	50	50	50	50	
			L	50	50	50	50	50	50	50	50	50	50	50	
	Heating	Heating Capacity	H	kW	2.93	3.95	5.22	5.94	7.16	10.05	11.45	12.85	17.6	22.65	
			M	2.45	3.68	4.59	4.84	6.41	8.04	10.29	12.39	16.98	21.73		
			L	1.98	2.91	2.84	3.91	5.55	6.73	8.74	10.86	13.33	17.18		
		Max. Electric Heater Capacity		2	3	4	5		6						
	Cooling	Cooling Capacity	H	kW	2.36	3.17	4.04	4.7	5.46	8.15	8.63	9.78	13.8	16.59	
			M		1.97	2.94	3.54	3.82	4.88	6.53	7.83	9.48	13.34	16.06	
			L		1.59	2.33	2.22	3.11	4.22	5.51	6.69	8.26	10.5	12.56	
		Sensible Cooling Capacity	H		1.68	2.26	2.93	3.37	3.88	5.82	6.26	7.08	9.98	11.96	
			M		1.39	2.08	2.53	2.7	3.45	4.58	5.63	6.84	9.63	11.56	
			L		1.11	1.63	1.55	2.18	2.97	3.84	4.78	5.89	7.44	8.88	
	Sound	Sound Pressure Level (Outlet)	dB(A)	48/47/43	50/49/46	52/50/44	52/51/46	54/52/49	53/52/47	56/54/50	58/55/52	58/54/50	59/57/55		
		Sound Pressure Level (Inlet + Radiated)		50/49/45	52/51/48	54/52/46	54/53/48	56/54/51	55/54/49	58/56/52	60/57/54	60/56/52	61/59/57		
		Sound Power Level (Outlet)		57/56/52	59/58/55	61/59/53	61/60/55	63/61/58	62/61/56	65/63/59	67/64/61	67/63/59	68/66/64		
		Sound Power Level (Inlet + Radiated)		59/58/54	61/60/57	63/61/55	63/62/57	65/63/60	64/63/58	67/65/61	69/66/63	69/65/61	70/68/66		
		Fan Motor Running Current @ H		A	0.46	0.55	0.72	0.83	0.89	1.3	1.57	1.95	3.16	3.3	
	Electrical	Fan Power	H	W	53	63	83	96	102	150	180	224	363	380	
			M	43	52	58	68	84	128	147	190	286	310		
			L	26	31	35	49	62	84	94	113	170	190		
		Hydraulic	Cooling Water Flow Rate	H	L/h	405	544	692	805	936	1397	1480	1676	2366	2844
				M	338	503	606	654	837	1120	1343	1625	2286	2753	
				L	272	400	381	533	723	944	1147	1416	1800	2153	
			Cooling Pressure Drop	H	kPa	23.75	44.61	24.87	35.19	49.63	60.25	23.33	30.6	66.17	99.07
				M	17.14	38.84	19.62	24.23	40.6	40.44	19.58	28.96	62.21	93.44	
				L	11.62	25.66	8.51	16.75	31.23	29.74	14.75	22.58	40.43	60	
Heating Water Flow Rate			H	L/h	251	338	447	509	614	861	981	1101	1509	1941	
			M	210	315	394	415	550	689	882	1062	1455	1862		
			L	169	250	244	336	476	577	749	931	1142	1472		
Heating Pressure Drop	H	kPa	5.02	9.58	17.5	7.8	11.87	28.9	17.4	22.67	15.22	25.88			
	M	3.64	8.45	13.91	5.39	9.73	19.36	14.36	21.25	14.26	24.01				
	L	2.47	5.54	5.86	3.68	7.51	14.04	10.7	16.75	9.22	15.74				
Cooling water content	L	0.72	0.87	1.02	1.17	1.32	1.92	2.07	2.22	2.59	2.84				
Heating water content	L	0.24	0.29	0.34	0.39	0.44	0.64	0.69	0.74	0.86	0.95				
Construction and Packing Data	Water Connections	Type	Socket(Threaded Female)												
		In / Out	mm [in]	19.05 [3/4]											
	Condensate Drainage Connection														
	Dimensions	L	mm	755	855	955	1055	1155	1555	1655	1795	1655	1915		
		W		590								660			
		H		250								300			
Net Weight	kg	17	23	24	28	31	36	43	45	51	60				

Note:

a. Cooling mode:

- Return air temperature: 27C DB/ 19C WB.

- Inlet/ outlet water temperature: 7C/ 12C.

b. Heating mode:

- Return air temperature: 20C.

- Inlet/ outlet water temperature: 65C/55C.

Note: For I-control models only, dimension "L" adds 100 mm.

Product range: PDWA-4R+1-ECM Low Static Hydronic Ducted Fan Coil Unit
 PDWA-4R+1-P~ECM Hydronic Ducted 4-pipe Unit with 4-row Cooling and 1-row Heating Coils and EC motor

PDWA(4R+1)-[Size]-P~ECM				200	300	400	500	600	800	1000	1200	1400	1600		
Unit Configuration		Configuration		4-pipe											
		Number Of Fan Blowers		Single		Twin		Three		Four		Three		Four	
		Power Supply (V/Ph/Hz)		220-240 / 1 / 50-60											
Performance Data	Air	Air Flow	H	m³/hr	408	561	762	869	1065	1462	1694	1934	2800	3734	
			M		322	509	642	663	916	1091	1484	1840	2674	3565	
			L		244	375	351	508	763	873	1207	1547	1953	2604	
		Available pressure	H	Pa	50	50	50	50	50	50	50	50	50	50	50
			M		50	50	50	50	50	50	50	50	50	50	
			L		50	50	50	50	50	50	50	50	50	50	
	Cooling	Cooling Capacity	H	kW	2.64	3.45	4.61	5.65	6.5	8.86	10.82	12.36	16.67	19.94	
			M		2.21	3.20	4.06	4.58	5.83	7.06	9.78	11.90	16.12	19.26	
			L		1.79	2.52	2.55	3.74	5.05	5.92	8.41	10.38	12.66	15.13	
		Sensible Cooling Capacity	H	kW	1.84	2.41	3.21	4.75	4.56	6.2	7.55	8.62	11.8	14.15	
			M		1.52	2.22	2.80	3.79	4.04	4.85	6.76	8.27	11.40	13.65	
			L		1.22	1.72	1.71	3.07	3.48	4.04	5.76	7.13	8.79	10.55	
	Heating	Heating Capacity	H	kW	1.81	2.41	3.16	3.63	4.27	6.06	6.84	7.72	10.33	13.26	
			M		1.51	2.25	2.79	2.94	3.81	4.84	6.18	7.45	10.03	12.76	
			L		1.22	1.77	1.75	2.38	3.31	4.07	5.29	6.46	7.86	10.06	
		Max. Electric Heater Capacity		2	3	4	5		6						
	Sound	Sound Pressure Level (Outlet)	dB(A)	43/40/3	47/44/3	47/44/4	49/46/4	51/49/4	51/47/4	55/53/4	55/52/5	54/51/4	57/55/5		
				6	9	1	2	6	5	9	0	8	2		
		Sound Pressure Level (Inlet + Radiated)		46/43/3	50/47/4	50/47/4	52/49/4	54/52/4	54/50/4	58/56/5	58/55/5	57/54/5	60/58/5		
		9		2	4	5	9	8	2	3	1	5			
		Sound Power Level (Outlet)		52/49/4	56/53/4	56/53/5	58/55/5	60/58/5	60/56/5	64/62/5	64/61/5	63/60/5	66/64/6		
		5		8	0	1	5	4	8	9	7	1			
	Sound Power Level (Inlet + Radiated)	55/52/4	59/56/5	59/56/5	61/58/5	63/61/5	63/59/5	67/65/6	67/64/6	66/63/6	69/67/6				
	8	1	3	4	8	7	1	2	0	4					
	Electrical	Fan Motor Power	H	W	40	60	60	82	105	136	189	224	322	436	
			M		24	40	40	56	82	95	133	165	193	265	
			L		17	24	31	38	55	73	77	87	127	143	
		Fan Motor Running Current @ H	A	0.46	0.55	0.72	0.83	0.89	1.3	1.57	1.95	3.16	3.3		
	Hydraulic	Cooling Water Flow Rate	H	L/h	452	592	790	968	1115	1520	1855	2119	2858	3418	
			M		379	549	695	786	999	1210	1677	2040	2763	3302	
L			306		432	436	641	866	1015	1441	1780	2170	2594		
Cooling Pressure Drop		H	kPa	38.61	69.02	126.66	65.1	90.48	93.64	139.53	186.79	123.25	182.92		
		M		28.10	60.35	100.70	44.71	74.25	62.16	116.30	174.44	116.01	171.93		
		L		19.13	39.23	43.55	30.98	57.43	45.29	88.55	136.44	75.08	111.34		
Heating Water Flow Rate		H	L/h	155	207	271	311	366	519	586	661	886	1136		
		M		129	193	239	252	326	415	530	638	859	1094		
		L		105	152	150	204	284	349	453	554	673	863		
Heating Pressure Drop		H	kPa	7.08	13.37	24.21	34	7.16	17.87	23.66	31.18	4.82	8.12		
		M		5.12	11.77	19.25	23.20	5.83	11.93	19.71	29.24	4.57	7.57		
		L		3.50	7.67	8.36	15.85	4.54	8.74	14.88	22.67	2.95	4.94		
Cooling water content	L	0.72	0.87	1.02	1.17	1.32	1.92	2.07	2.22	2.59	2.84				
Heating water content	L	0.24	0.29	0.34	0.39	0.44	0.64	0.69	0.74	0.86	0.95				
Construction and Packing Data	Water Connections	Type	Socket(Threaded Female)												
		In													
	Condensate Drainage Connection	mm [in]	19.05 [3/4]												
		L	755	855	955	1055	1155	1555	1655	1795	1655	1915			
	Dimensions	W	590								660				
		H	250								300				
Net Weight	kg	17	23	24	28	31	36	43	45	51	60				

Note:

a. Cooling mode:

- Return air temperature: 27C DB/ 19C WB.

- Inlet/ outlet water temperature: 7C/ 12C.

b. Heating mode:

- Return air temperature: 20C.

- Inlet/ outlet water temperature: 65C/55C.

Note: For I-control models only, dimension "L" adds 100 mm.

Product range: PDWA-4R+2-ECM Low Static Hydronic Ducted Fan Coil Unit
 PDWA-4R+2-P~ECM Hydronic Ducted 4-pipe Unit with 4-row Cooling and 2-row Heating Coils and EC motor

PDWA(4R+2)-[Size]-P~ECM				200	300	400	500	600	800	1000	1200	1400	1600			
Unit Configuration		Configuration		4-pipe												
		Number Of Fan Blowers		Single		Twin		Three		Four		Three		Four		
		Power Supply (V/Ph/Hz)		220-240 / 1 / 50-60												
Performance Data	Air	Air Flow	H	m ³ /hr	380	532	717	822	1013	1375	1626	1860	2708	3611		
			M		294	482	599	612	869	1005	1422	1773	2591	3454		
			L		225	357	317	475	731	817	1166	1498	1897	2529		
		Available pressure	H	Pa	50	50	50	50	50	50	50	50	50	50	50	50
			M		50	50	50	50	50	50	50	50	50	50	50	
			L		50	50	50	50	50	50	50	50	50	50	50	
	Cooling	Cooling Capacity	H	kW	2.52	3.3	4.41	5.4	6.26	8.42	10.5	11.99	16.23	19.37		
			M		2.06	3.08	3.86	4.31	5.57	6.64	9.53	11.53	15.68	18.83		
			L		1.67	2.44	2.34	3.55	4.89	5.63	8.14	10.18	12.42	14.89		
		Sensible Cooling Capacity	H	kW	1.75	2.3	3.07	4.52	4.37	5.87	7.31	8.34	11.48	13.74		
			M		1.41	2.13	2.65	3.56	3.85	4.55	6.57	7.98	11.07	13.32		
			L		1.13	1.66	1.57	2.90	3.36	3.84	5.58	6.98	8.62	10.36		
	Heating	Heating Capacity	H	kW	2.79	3.8	4.98	5.7	6.88	9.59	11.07	12.51	17.23	22.03		
			M		2.30	3.53	4.35	4.51	6.11	7.53	9.99	12.05	16.60	21.26		
			L		1.86	2.78	2.65	3.70	5.36	6.37	8.53	10.61	13.05	16.84		
		Max. Electric Heater Capacity			2	3	4	5		6						
	Sound	Sound Pressure Level (Outlet)		dB(A)	43/40/36	47/44/39	47/44/41	49/46/42	51/49/46	51/47/45	55/53/49	55/52/50	54/51/48	57/55/52		
					46/43/39	50/47/42	50/47/44	52/49/45	54/52/49	54/50/48	58/56/52	58/55/53	57/54/51	60/58/55		
		(Inlet + Radiated)														
		Sound Power Level (Outlet)			52/49/45	56/53/48	56/53/50	58/55/51	60/58/55	60/56/54	64/62/58	64/61/59	63/60/57	66/64/61		
		Sound Power Level (Inlet + Radiated)			55/52/48	59/56/51	59/56/53	61/58/54	63/61/58	63/59/57	67/65/61	67/64/62	66/63/60	69/67/64		
	Electrical	Fan Motor Power	H	W	40	60	60	82	105	136	189	224	322	436		
			M		24	40	40	56	82	95	133	165	193	265		
			L		17	24	31	38	55	73	77	87	127	143		
		Fan Motor Running Current @ H		A	0.46	0.55	0.72	0.83	0.89	1.3	1.57	1.95	3.16	3.3		
	Hydraulic	Cooling Water Flow Rate	H	L/h	432	566	756	925	1074	1444	1801	2056	2782	3321		
			M		353	528	661	738	956	1138	1634	1977	2687	3228		
			L		286	418	402	608	839	965	1396	1746	2130	2553		
		Cooling Pressure Drop	H	kPa	35.53	63.75	117.2	60.02	84.54	85.39	132.18	176.88	117.44	173.67		
M			24.69		56.21	91.96	40.00	68.54	55.67	110.94	164.84	110.35	165.04			
L			16.97		36.88	37.55	28.18	54.20	41.33	83.58	131.77	72.62	108.15			
Heating Water Flow Rate		H	L/h	239	326	427	488	590	822	949	1072	1477	1889			
		M		197	302	373	387	524	645	856	1033	1423	1823			
		L		159	238	227	317	459	546	731	909	1118	1443			
Heating Pressure Drop		H	kPa	4.58	8.94	16.12	7.24	11.05	26.57	16.37	21.6	14.64	24.63			
		M		3.25	7.83	12.61	4.76	8.93	17.18	13.61	20.21	13.69	23.10			
		L		2.21	5.08	5.16	3.32	7.05	12.74	10.23	16.06	8.88	15.18			
	cooling water content		L	0.72	0.87	1.02	1.17	1.32	1.92	2.07	2.22	2.59	2.84			
	heating water content		L	0.24	0.29	0.34	0.39	0.44	0.64	0.69	0.74	0.86	0.95			
Construction and Packing Data	Water Connections	Type	Socket(Threaded Female)													
		In Out														
	Condensate Drainage Connection	mm [in]	19.05 [3/4]													
	Dimensions	L	mm	755	855	955	1055	1155	1555	1655	1795	1655	1915			
		W		590								660				
		H		250								300				
Net Weight		kg	17	23	24	28	31	36	43	45	51	60				

Note:

a. Cooling mode:

- Return air temperature: 27C DB/ 19C WB

- Inlet/ outlet water temperature: 7C/ 12C

b. Heating mode:

- Return air temperature: 20C.

- Inlet/ outlet water temperature: 65C/55C.

Note: For I-control models only, dimension "L" adds 100 mm.

A.3. Coil Data

3-row Coils

Model	Fin height (mm)	Fin Length (mm)	Fins per Inch	No. of Rows	Fin width (mm)	No. of Circuits	Tube \emptyset (mm)
PDWA(3R)-200	200	480	12.7	3	66	2	9.52
PDWA(3R)-300		580				2	
PDWA(3R)-400		680				3	
PDWA(3R)-500		780				3	
PDWA(3R)-600		880				3	
PDWA(3R)-800		1280				4	
PDWA(3R)-1000		1380				6	
PDWA(3R)-1200	250	1480	6				
PDWA(3R)-1400		1380	6				
PDWA(3R)-1600		1480	6				

4-row Coils

Model	Fin height (mm)	Fin Length (mm)	Fins per Inch	No. of Rows	Fin width (mm)	No. of Circuits	Tube \emptyset (mm)
PDWA(4R)-200	200	480	12.7	4	88	2	9.52
PDWA(4R)-300		580				2	
PDWA(4R)-400		680				2	
PDWA(4R)-500		780				3	
PDWA(4R)-600		880				3	
PDWA(4R)-800		1280				4	
PDWA(4R)-1000		1380				4	
PDWA(4R)-1200	250	1480	4				
PDWA(4R)-1400		1380	6				
PDWA(4R)-1600		1480	6				

6-row Coils

Model	Fin height (mm)	Fin Length (mm)	Fins per Inch	No. of Rows	Fin width (mm)	No. of Circuits	Tube \emptyset (mm)
PDWA(6R)-200	200	480	12.7	6	110	2	9.52
PDWA(6R)-300		580				2	
PDWA(6R)-400		680				3	
PDWA(6R)-500		780				3	
PDWA(6R)-600		880				4	
PDWA(6R)-800		1280				4	
PDWA(6R)-1000		1380				5	
PDWA(6R)-1200	250	1480	5				
PDWA(6R)-1400		1380	6				
PDWA(6R)-1600		1480	6				

Heating Coil Data (4-pipe system 1-row heating coil)

Model	Fin height (mm)	Fin Length (mm)	Fins per Inch	No. of Rows	Fin width (mm)	No. of Circuits	Tube \emptyset (mm)
PDWA(1R)-200	200	480	12.7	3	22	1	9.52
PDWA(1R)-300		580				1	
PDWA(1R)-400		680				1	
PDWA(1R)-500		780				1	
PDWA(1R)-600		880				2	
PDWA(1R)-800		1280				2	
PDWA(1R)-1000		1380				2	
PDWA(1R)-1200	250	1480	2				
PDWA(1R)-1400		1380	5				
PDWA(1R)-1600		1480	5				

Heating Coil Data (4-pipe system with 2-row removable heating coil)

Model	Fin height (mm)	Fin Length (mm)	Fins per Inch	No. of Rows	Fin width (mm)	No. of Circuits	Tube \varnothing (mm)
PDWA(2R)-200	200	480	12.7	2	44	2	9.52
PDWA(2R)-300		580				2	
PDWA(2R)-400		680				2	
PDWA(2R)-500		780				2	
PDWA(2R)-600		880				2	
PDWA(2R)-800		1280				3	
PDWA(2R)-1000		1380				3	
PDWA(2R)-1200		1480				4	
PDWA(2R)-1400		250				1380	
PDWA(2R)-1600	1480		5				

A.4. Sound Power Data (Inlet + Radiated)

Model		PDWA(3R)-200-ECM										
speed	H(1250)	M(1150)	L(950)	700RPM	800RPM	900RPM	1000RPM	1100RPM	1200RPM	1300RPM	1400RPM	
Sound Power dB(A)	60.1	58.0	52.6	44.2	47.5	51.5	53.7	56.6	59.3	60.8	63.0	
Sound Power in 1/3 Octave-bands under rated ESP (dB)	20 Hz	20.2	19.4	21.0	20.5	15.2	22.7	19.3	17.3	21.5	19.0	19.2
	25 Hz	17.8	22.0	19.1	17.7	17.1	18.2	20.0	24.3	19.7	15.8	20.0
	31.5 Hz	13.4	14.5	16.7	19.3	15.6	17.8	15.6	16.2	12.8	14.0	20.0
	40 Hz	15.7	13.8	12.2	8.4	13.8	9.3	15.2	13.6	14.1	17.3	15.9
	50 Hz	20.1	19.9	15.2	17.8	17.7	14.7	15.7	18.3	21.5	18.6	19.6
	63 Hz	24.5	22.2	19.4	13.8	19.3	19.5	19.4	22.6	21.8	27.2	27.0
	80 Hz	26.3	22.8	17.8	11.5	15.1	16.3	19.4	19.9	25.8	26.9	26.7
	100 Hz	29.6	28.9	23.1	14.9	18.4	22.8	23.5	27.9	29.9	29.3	32.2
	125 Hz	38.7	35.4	29.1	22.6	23.8	28.3	29.8	33.3	37.5	40.0	41.0
	160 Hz	43.1	40.2	36.4	27.4	29.7	36.1	36.6	37.8	42.6	43.5	43.2
	200 Hz	45.7	42.7	37.5	29.1	33.0	36.8	38.2	41.0	44.4	47.0	47.3
	250 Hz	46.4	44.3	38.9	29.5	34.1	38.8	39.0	42.5	46.0	46.8	50.6
	315 Hz	48.9	48.4	41.5	33.9	37.4	39.9	43.1	47.6	49.2	48.6	51.7
	400 Hz	51.5	50.2	44.7	38.2	40.3	43.5	45.9	49.1	51.2	51.9	54.6
	500 Hz	50.3	48.8	43.7	35.7	39.2	43.3	44.1	47.2	50.5	50.2	53.6
	630 Hz	50.9	48.5	43.7	34.7	38.9	42.5	44.9	47.2	49.8	51.9	52.8
	800 Hz	50.3	48.3	43.4	33.5	38.2	41.7	45.1	47.4	49.2	51.5	54.2
	1000 Hz	50.1	47.2	42.9	33.4	36.4	41.2	44.6	45.8	48.7	51.5	53.1
1250 Hz	46.6	44.2	40.1	29.5	33.5	38.5	41.8	43.2	45.2	48.0	50.2	
1600 Hz	47.4	45.2	39.9	29.4	33.9	38.7	41.1	43.9	46.4	48.3	49.7	
2000 Hz	46.0	43.6	37.5	26.0	30.6	36.1	38.9	42.6	44.6	47.4	48.9	
2500 Hz	44.2	41.3	34.5	23.8	27.8	32.8	36.2	39.9	42.7	45.7	47.7	
3150 Hz	41.3	38.4	31.8	22.0	24.5	30.1	33.6	36.9	39.9	42.7	45.0	
4000 Hz	38.3	35.2	28.2	20.6	21.9	26.4	30.0	33.5	36.8	39.8	42.5	
5000 Hz	35.3	31.8	25.3	20.1	20.8	23.9	26.7	30.2	33.5	37.0	39.1	
6300 Hz	31.7	28.3	22.4	19.6	19.5	21.5	23.4	26.7	30.0	33.5	36.2	
8000 Hz	29.0	25.5	20.5	18.6	18.9	19.7	21.3	23.8	27.2	30.8	33.6	
10000 Hz	25.3	22.0	17.7	16.8	16.8	17.2	18.3	20.3	23.6	27.0	30.0	
12500 Hz	19.7	16.9	14.4	13.7	13.8	14.2	14.5	15.9	17.9	21.4	24.4	
16000 Hz	20.2	18.8	16.0	13.6	14.3	15.4	16.6	18.0	19.6	20.9	21.9	

Model		PDWA(3R)-300-ECM										
speed	H(1350)	M(1250)	L(1050)	700RPM	800RPM	900RPM	1000RPM	1100RPM	1200RPM	1300RPM	1400RPM	
Sound Power dB(A)	62.4	60.4	55.7	44.8	49.0	51.6	54.4	57.0	59.3	61.4	63.3	
Sound Power in 1/3 Octave-bands under rated ESP (dB)	20 Hz	15.4	12.2	14.8	15.7	16.9	17.9	17.2	12.4	10.0	14.5	16.4
	25 Hz	18.0	14.9	15.9	17.2	19.9	11.9	18.4	13.4	12.7	17.0	18.9
	31.5 Hz	15.6	13.7	12.5	13.0	13.9	10.3	11.2	13.9	9.3	18.1	13.0
	40 Hz	11.9	7.7	9.4	9.8	8.0	6.7	7.5	11.3	6.2	9.2	14.7
	50 Hz	16.2	15.5	13.1	16.4	14.7	13.1	13.8	12.4	14.3	16.7	15.8
	63 Hz	22.1	20.1	17.8	19.0	18.4	17.1	19.2	16.5	19.3	21.0	23.3
	80 Hz	28.1	26.7	19.8	14.1	13.3	19.0	18.0	21.6	24.5	29.0	27.3
	100 Hz	30.5	30.2	25.9	17.7	20.5	23.7	24.3	27.4	30.7	29.6	31.5
	125 Hz	37.5	34.5	33.5	24.8	25.2	31.6	34.1	32.9	33.0	35.9	39.0
	160 Hz	45.8	43.7	41.4	30.1	33.9	37.8	40.0	42.9	43.3	44.0	47.6
	200 Hz	47.5	46.0	41.6	29.1	34.2	36.6	39.5	43.7	45.2	46.8	48.3
	250 Hz	49.9	47.7	40.8	29.4	34.0	38.3	39.5	42.2	46.5	48.8	51.0
	315 Hz	51.5	49.5	44.7	35.0	38.7	39.2	44.2	45.1	49.0	50.1	53.0
	400 Hz	53.1	51.4	46.8	35.4	40.0	43.8	46.5	47.1	50.8	52.1	54.1
	500 Hz	55.3	53.4	49.6	38.8	43.3	45.9	48.1	51.1	52.5	54.3	56.2
	630 Hz	51.3	49.7	45.6	33.9	37.7	40.8	44.1	47.2	49.3	50.1	52.6
	800 Hz	52.9	50.7	45.9	35.5	39.7	42.3	44.4	47.4	49.6	51.7	54.2
	1000 Hz	50.3	48.2	43.9	32.9	36.0	39.8	42.7	45.1	47.2	49.1	51.5
1250 Hz	48.0	45.6	41.1	30.4	34.0	36.8	39.7	42.5	44.4	46.9	49.0	
1600 Hz	48.7	46.5	41.8	30.2	34.5	37.3	40.3	43.3	45.8	47.2	50.2	
2000 Hz	48.7	46.6	42.0	27.3	33.4	36.9	40.3	43.6	45.4	47.9	49.5	
2500 Hz	46.2	44.2	39.1	23.5	28.3	33.4	37.4	40.7	42.9	45.5	46.9	
3150 Hz	44.1	41.7	35.6	21.0	24.7	29.1	33.8	37.4	40.3	43.1	45.2	
4000 Hz	41.5	38.8	32.4	19.3	21.9	26.0	30.4	34.5	37.3	40.3	42.8	
5000 Hz	39.1	36.1	29.2	18.2	19.8	23.6	27.1	31.3	34.5	37.7	40.5	
6300 Hz	34.3	31.2	24.4	17.2	17.9	19.9	22.5	26.2	29.4	33.0	35.5	
8000 Hz	31.8	28.6	21.6	16.5	16.7	17.7	19.8	23.4	26.8	30.3	33.2	
10000 Hz	27.9	24.7	18.3	14.6	14.8	15.3	16.9	19.7	23.1	26.4	29.5	
12500 Hz	21.6	18.5	13.6	11.9	11.9	11.9	12.6	14.6	16.8	20.2	23.1	
16000 Hz	18.0	16.5	14.0	10.9	12.1	12.9	13.6	14.5	15.7	17.3	18.7	

Model		PDWA(3R)-400-ECM										
speed	H(1150)	M(1050)	L(950)	700RPM	800RPM	900RPM	1000RPM	1100RPM	1200RPM	1300RPM	1400RPM	
Sound Power dB(A)	60.4	58.3	55.9	47.5	50.9	54.5	57.3	59.3	61.4	63.6	65.3	
Sound Power in 1/3 Octave-bands under rated ESP (dB)	20 Hz	18.7	18.5	18.7	17.9	19.5	14.7	22.8	14.3	23.0	22.6	22.2
	25 Hz	18.1	16.8	17.8	18.1	17.9	16.5	19.2	14.5	21.8	20.1	22.0
	31.5 Hz	15.2	12.5	12.0	20.6	14.6	13.7	10.3	14.7	15.7	15.9	15.3
	40 Hz	15.2	13.8	14.1	12.9	9.3	13.5	14.7	13.0	17.4	16.2	21.1
	50 Hz	17.7	16.0	14.8	14.6	18.2	14.3	15.3	16.7	18.6	17.2	19.4
	63 Hz	22.6	22.1	20.5	16.8	15.5	17.8	23.2	21.1	24.0	23.7	24.8
	80 Hz	23.7	22.7	20.4	13.8	14.0	18.7	22.1	23.3	24.2	26.8	30.0
	100 Hz	27.7	28.1	24.3	17.3	18.0	21.2	27.3	28.8	26.6	32.7	30.4
	125 Hz	33.9	31.2	30.0	22.4	27.1	29.9	30.1	32.3	35.5	35.5	39.6
	160 Hz	40.6	37.7	35.7	28.7	29.7	34.8	36.6	38.9	42.4	44.4	44.9
	200 Hz	42.1	39.4	37.5	28.6	32.4	36.8	38.3	40.5	43.6	45.8	45.3
	250 Hz	43.9	41.6	39.1	28.8	32.9	37.7	40.4	42.7	45.2	46.1	50.0
	315 Hz	48.4	45.6	44.2	36.0	39.7	43.8	44.7	46.5	50.3	53.0	54.9
	400 Hz	50.7	48.6	47.2	38.8	42.3	46.3	48.1	49.2	52.2	53.1	56.4
	500 Hz	50.7	48.1	45.9	38.3	41.3	44.9	46.8	49.4	52.0	54.1	55.1
	630 Hz	52.0	49.9	47.3	39.9	43.4	46.1	48.5	51.3	52.8	54.6	57.1
	800 Hz	51.8	49.8	47.3	38.8	42.7	46.0	48.6	51.1	52.6	55.8	56.9
	1000 Hz	51.2	48.5	45.9	36.8	41.8	44.5	47.2	49.9	52.6	53.3	55.4
	1250 Hz	49.2	46.8	44.1	34.7	39.6	42.5	45.7	47.8	50.6	51.9	53.7
	1600 Hz	49.6	47.1	44.1	35.4	38.9	42.4	45.8	48.3	50.8	52.6	54.2
2000 Hz	47.2	44.4	41.2	31.2	35.9	39.6	42.8	46.0	48.4	50.3	52.9	
2500 Hz	45.6	42.5	39.0	28.1	32.7	37.1	41.0	44.0	47.2	49.4	51.3	
3150 Hz	44.1	41.3	37.9	26.3	31.1	35.5	40.2	42.3	45.8	47.4	49.6	
4000 Hz	38.8	38.6	35.0	21.5	25.5	30.0	40.0	37.3	40.2	42.7	45.2	
5000 Hz	36.2	35.5	31.8	20.1	22.7	27.1	36.5	34.5	38.0	40.7	43.0	
6300 Hz	31.6	31.2	27.5	19.1	20.1	22.7	32.3	30.1	33.2	36.3	39.2	
8000 Hz	30.2	30.2	26.7	18.1	19.1	21.4	32.0	28.5	31.8	35.3	38.3	
10000 Hz	25.7	25.3	21.8	15.7	16.1	17.2	26.5	24.1	27.3	30.7	33.9	
12500 Hz	19.6	21.1	19.0	13.6	14.4	14.1	23.9	18.3	21.0	25.1	28.0	
16000 Hz	30.7	31.3	31.6	31.2	31.7	31.6	31.5	31.0	30.4	30.7	30.8	

Model		PDWA(3R)-500-ECM												
speed	H(1250)	M(1150)	L(1000)	500RPM	600RPM	700RPM	800RPM	900RPM	1000RPM	1100RPM	1200RPM	1300RPM	1400RPM	
Sound Power dB(A)	62.1	60.1	56.4	41.8	44.2	47.3	50.5	53.5	56.4	59.0	61.1	63.1	65.1	
Sound Power in 1/3 Octave-bands under rated ESP (dB)	20 Hz	21.4	22.3	12.3	16.9	21.9	16.4	12.8	18.4	12.3	19.7	24.9	17.8	15.7
	25 Hz	17.2	17.7	14.7	20.2	22.3	18.2	21.7	19.9	14.7	19.2	16.2	18.2	18.0
	31.5 Hz	18.1	15.4	19.7	18.2	15.8	18.2	18.3	12.0	19.7	13.2	17.7	18.5	18.0
	40 Hz	19.4	18.9	19.7	8.8	14.7	14.3	13.4	12.8	19.7	17.2	20.5	18.2	19.7
	50 Hz	19.4	19.3	17.9	13.0	16.4	17.9	14.5	14.9	17.9	19.8	18.7	20.1	20.5
	63 Hz	24.8	24.0	21.5	9.3	15.9	12.6	15.1	20.1	21.5	24.8	23.3	26.4	28.5
	80 Hz	28.8	27.2	25.4	11.0	13.3	16.8	18.0	21.6	25.4	27.2	27.3	30.4	32.3
	100 Hz	36.2	35.3	33.4	28.6	29.2	29.9	30.6	31.8	33.4	35.3	35.2	37.2	37.2
	125 Hz	40.3	37.8	33.0	14.6	19.9	21.8	23.8	30.3	33.0	36.8	38.8	41.8	42.5
	160 Hz	44.2	41.6	37.4	20.4	24.1	27.6	30.4	33.7	37.4	40.6	42.6	45.9	46.9
	200 Hz	45.0	43.6	39.8	22.5	27.6	30.2	33.8	37.0	39.8	43.7	43.5	46.6	49.1
	250 Hz	45.1	43.3	41.2	21.6	27.2	28.9	34.2	37.4	41.2	42.8	43.7	46.4	49.0
	315 Hz	48.3	47.0	43.7	26.5	30.6	32.9	37.2	40.2	43.7	46.7	47.3	49.3	51.9
	400 Hz	51.2	48.7	45.1	27.9	32.1	36.1	40.1	42.3	45.1	47.6	49.9	52.5	53.8
	500 Hz	54.1	52.9	49.5	29.8	36.7	39.6	43.5	46.6	49.5	52.2	53.6	54.6	58.4
	630 Hz	53.9	52.3	49.1	28.9	35.2	39.7	42.8	45.4	49.1	51.4	53.2	54.5	56.9
	800 Hz	51.7	49.9	46.7	27.3	31.6	37.3	40.3	43.4	46.7	49.2	50.6	52.8	54.0
	1000 Hz	52.9	51.1	47.3	27.2	30.8	36.2	40.3	44.5	47.3	49.9	52.3	53.6	55.2
	1250 Hz	50.0	48.0	44.7	26.7	29.5	33.9	37.5	41.1	44.7	46.9	49.0	51.0	52.9
	1600 Hz	50.3	48.0	45.0	26.5	29.1	33.2	36.9	41.3	45.0	46.7	49.3	51.4	53.4
2000 Hz	49.1	46.5	42.4	26.6	28.1	32.1	34.9	39.2	42.4	45.3	47.7	50.4	52.4	
2500 Hz	46.9	44.3	40.2	27.5	27.8	30.5	32.8	36.5	40.2	43.0	45.6	48.2	50.2	
3150 Hz	45.3	42.3	37.9	27.4	28.3	29.5	30.6	33.9	37.9	40.9	43.7	46.8	48.5	
4000 Hz	41.7	38.9	34.6	28.2	28.6	29.3	29.8	31.7	34.6	37.4	40.5	42.9	45.5	
5000 Hz	39.3	36.6	32.5	28.4	28.8	29.5	29.7	31.3	32.5	35.3	38.0	40.5	42.7	
6300 Hz	36.1	34.1	31.4	28.4	29.4	29.3	29.6	31.0	31.4	33.3	34.9	37.2	39.7	
8000 Hz	34.3	33.0	30.8	28.6	29.2	29.6	29.7	30.4	30.8	32.5	33.6	35.0	37.3	
10000 Hz	32.5	31.5	30.3	28.6	28.9	29.6	29.2	29.9	30.3	31.0	31.9	33.0	34.3	
12500 Hz	30.9	30.2	29.6	27.6	28.0	28.9	28.1	29.5	29.6	29.9	30.6	31.2	32.0	
16000 Hz	39.6	39.0	39.0	34.0	34.8	35.6	35.7	37.4	39.0	38.9	39.1	40.0	39.8	

Model		PDWA(3R)-600-ECM												
speed	H(1350)	M(1250)	L(1100)	500RPM	600RPM	700RPM	800RPM	900RPM	1000RPM	1100RPM	1200RPM	1300RPM	1400RPM	
Sound Power dB(A)	65.2	63.2	60.0	42.0	45.4	49.1	52.4	57.1	57.9	60.0	62.2	64.2	66.2	
Sound Power in 1/3 Octave-bands under rated ESP (dB)	20 Hz	19.0	19.9	16.4	19.6	18.9	18.4	17.3	13.6	21.2	16.4	19.5	20.2	17.8
	25 Hz	17.8	17.7	19.1	21.6	25.1	17.2	20.2	17.2	24.4	19.1	17.6	17.7	17.8
	31.5 Hz	18.1	19.0	15.3	23.6	18.1	19.4	16.3	14.2	21.6	15.3	20.0	17.9	18.3
	40 Hz	18.0	19.4	15.5	14.7	15.0	13.4	13.0	12.4	15.4	15.5	17.1	21.7	14.3
	50 Hz	19.8	20.3	19.1	16.1	15.9	17.6	18.7	16.8	18.4	19.1	20.9	19.6	20.0
	63 Hz	28.0	23.3	23.5	12.3	15.4	18.5	18.3	18.4	21.8	23.5	21.3	25.3	30.7
	80 Hz	29.7	30.1	27.5	11.6	17.1	17.3	18.5	20.3	24.7	27.5	31.6	28.7	30.6
	100 Hz	38.5	35.8	34.1	26.1	27.6	28.3	30.0	31.0	32.6	34.1	35.1	36.4	40.5
	125 Hz	39.0	37.8	36.5	14.7	21.4	24.0	27.5	31.0	33.1	36.5	38.7	37.0	41.0
	160 Hz	46.6	44.7	42.2	22.1	26.7	30.8	33.2	37.8	42.5	42.2	43.8	45.7	47.6
	200 Hz	50.5	48.3	45.4	26.4	29.3	32.6	36.3	39.0	44.1	45.4	47.3	49.2	51.8
	250 Hz	50.3	47.8	44.8	24.7	29.5	32.0	35.7	41.1	41.7	44.8	46.5	49.2	51.4
	315 Hz	52.9	51.4	46.3	27.1	32.8	34.3	38.0	41.1	44.0	46.3	50.8	51.9	53.9
	400 Hz	54.3	52.2	49.8	30.0	33.8	38.5	41.9	45.0	47.3	49.8	50.8	53.6	55.0
	500 Hz	56.9	54.5	51.6	30.9	35.8	41.5	44.9	48.1	50.8	51.6	53.2	55.9	58.0
	630 Hz	56.4	55.1	52.3	32.8	38.2	42.2	45.0	49.2	50.3	52.3	54.7	55.5	57.4
	800 Hz	54.6	52.5	49.3	27.7	33.4	38.2	41.6	44.8	47.2	49.3	51.5	53.6	55.5
	1000 Hz	56.4	54.5	50.6	28.3	34.5	38.5	42.8	46.4	48.6	50.6	53.1	55.8	57.0
	1250 Hz	53.4	51.7	48.8	26.3	31.0	35.6	39.3	43.1	46.3	48.8	50.9	52.4	54.3
1600 Hz	54.1	52.2	49.1	27.0	31.3	36.2	39.6	43.3	46.1	49.1	51.1	53.4	54.9	
2000 Hz	53.2	51.1	47.2	26.7	29.8	33.3	37.6	42.0	44.9	47.2	50.0	52.3	54.2	
2500 Hz	51.2	49.1	45.8	27.1	28.7	31.0	34.6	38.8	42.5	45.8	47.8	50.3	52.1	
3150 Hz	50.3	47.9	42.8	26.0	28.2	29.5	32.0	36.1	40.1	42.8	46.5	49.4	51.2	
4000 Hz	47.6	45.1	40.0	27.0	27.9	28.4	30.0	33.4	37.2	40.0	43.7	46.4	48.8	
5000 Hz	44.2	41.7	37.4	27.4	28.3	28.5	29.4	32.2	34.8	37.4	40.4	43.1	45.4	
6300 Hz	40.8	38.6	34.1	28.0	28.8	28.8	28.8	30.4	32.2	34.1	37.3	39.8	41.9	
8000 Hz	38.2	36.0	32.3	27.7	28.5	28.1	28.2	29.9	31.1	32.3	34.9	37.2	39.2	
10000 Hz	35.0	33.3	30.7	27.1	28.1	27.5	27.5	28.9	29.8	30.7	32.3	34.3	35.8	
12500 Hz	31.7	30.6	28.8	25.8	26.8	26.6	26.6	27.6	28.8	28.8	30.2	31.0	32.4	
16000 Hz	38.2	38.1	37.6	32.7	34.0	34.2	35.3	36.3	37.6	37.6	38.0	38.2	38.3	

Model		PDWA(3R)-800-ECM												
speed	H(1250)	M(1150)	L(1000)	500RPM	600RPM	700RPM	800RPM	900RPM	1000RPM	1100RPM	1200RPM	1300RPM	1400RPM	
Sound Power dB(A)	63.7	61.6	58.0	42.4	45.3	49.0	52.4	55.1	58.0	60.7	62.5	64.9	66.9	
Sound Power in 1/3 Octave-bands under rated ESP (dB)	20 Hz	25.4	22.4	20.6	20.1	17.6	20.5	22.7	17.6	20.6	21.5	23.2	27.5	17.4
	25 Hz	20.2	17.8	22.2	18.8	17.3	19.6	24.2	14.9	22.2	18.1	17.6	22.8	21.2
	31.5 Hz	15.9	14.8	12.6	14.1	16.2	19.4	15.5	13.4	12.6	16.2	13.3	18.6	13.3
	40 Hz	18.2	17.5	15.7	14.5	16.2	13.7	17.6	13.3	15.7	15.8	19.2	17.3	21.9
	50 Hz	21.5	19.7	18.1	14.7	14.8	18.6	19.5	16.5	18.1	18.9	20.4	22.5	20.0
	63 Hz	26.5	24.3	23.7	15.3	15.4	14.7	18.7	20.8	23.7	22.6	25.9	27.2	27.4
	80 Hz	31.3	28.2	24.9	11.8	15.3	20.0	20.6	24.0	24.9	27.0	29.3	33.3	31.8
	100 Hz	35.5	34.1	32.1	26.0	26.3	26.5	27.1	28.9	32.1	34.0	34.2	36.8	37.6
	125 Hz	41.8	39.2	34.8	20.1	24.5	27.0	29.3	35.0	34.8	37.5	41.0	42.6	42.6
	160 Hz	47.6	45.5	40.6	23.8	28.8	32.5	35.3	37.5	40.6	44.0	47.1	48.0	51.1
	200 Hz	48.7	47.0	43.4	25.5	29.9	34.3	38.1	40.6	43.4	46.4	47.6	49.8	52.5
	250 Hz	48.7	46.6	42.2	26.3	30.6	33.5	37.2	38.7	42.2	45.4	47.8	49.6	52.1
	315 Hz	51.6	48.6	44.8	28.9	35.0	34.3	39.0	41.7	44.8	48.0	49.3	54.0	55.2
	400 Hz	53.6	51.2	47.5	33.4	35.7	40.5	42.7	46.4	47.5	50.7	51.8	55.4	56.0
	500 Hz	55.4	53.4	51.1	32.7	37.6	40.9	44.2	47.1	51.1	52.1	54.6	56.3	58.9
	630 Hz	55.4	54.0	50.6	31.0	36.7	41.6	44.2	46.7	50.6	53.8	54.3	56.5	57.9
	800 Hz	52.0	50.1	46.7	28.2	32.9	37.0	40.8	44.2	46.7	49.3	50.8	53.2	54.9
	1000 Hz	54.1	52.0	49.9	27.8	34.6	39.9	43.3	46.2	49.9	50.9	53.2	54.9	57.2
	1250 Hz	51.5	49.4	46.3	27.4	31.1	35.9	40.0	43.2	46.3	48.6	50.2	52.8	54.1
1600 Hz	52.4	49.9	46.0	25.9	29.7	35.1	39.6	42.6	46.0	48.7	51.1	53.8	55.6	
2000 Hz	51.6	49.1	44.6	26.0	28.3	32.9	37.5	41.3	44.6	47.7	50.5	52.7	54.5	
2500 Hz	49.4	46.8	42.5	26.8	27.4	31.0	34.6	39.1	42.5	45.3	48.3	50.4	52.5	
3150 Hz	47.9	45.1	41.1	27.4	27.8	29.6	33.1	37.2	41.1	43.6	46.6	49.2	51.7	
4000 Hz	44.7	41.8	36.9	27.4	28.2	28.6	30.4	33.7	36.9	40.2	43.4	45.9	48.7	
5000 Hz	41.5	38.6	34.1	28.4	28.2	28.2	29.2	31.4	34.1	36.9	40.2	42.8	45.5	
6300 Hz	38.4	35.7	31.2	28.4	28.7	28.4	28.8	30.0	31.2	34.0	37.3	39.5	42.4	
8000 Hz	36.2	33.7	30.1	28.3	28.9	28.4	28.6	29.6	30.1	32.0	35.3	37.1	39.8	
10000 Hz	33.3	31.3	28.8	27.7	28.2	28.0	28.3	28.5	28.8	29.9	32.7	33.9	36.2	
12500 Hz	30.1	28.9	27.4	27.0	27.1	26.8	27.1	26.9	27.4	27.9	29.8	30.3	31.9	
16000 Hz	35.2	34.8	34.5	32.8	32.8	33.5	33.6	33.4	34.5	34.5	35.1	35.3	35.8	

Model		PDWA(3R)-1000-ECM									
speed		H(1300)	M(1200)	L(1050)	800RPM	900RPM	1000RPM	1100RPM	1200RPM	1300RPM	1400RPM
Sound Power dB(A)		67.1	65.3	61.4	54.4	57.5	60.2	62.6	65.3	67.1	68.9
Sound Power in 1/3 Octave-bands under rated ESP (dB)	20 Hz	19.5	22.4	16.8	12.0	13.7	14.3	19.4	22.4	19.5	19.1
	25 Hz	21.4	16.4	16.3	11.1	16.1	16.8	15.8	16.4	21.4	18.8
	31.5 Hz	17.5	17.5	15.7	10.1	13.5	15.6	15.8	17.5	17.5	17.8
	40 Hz	21.4	15.7	15.7	8.1	12.7	14.8	16.7	15.7	21.4	21.4
	50 Hz	22.0	20.3	19.3	14.4	18.1	19.2	19.5	20.3	22.0	22.6
	63 Hz	28.1	28.4	23.9	16.8	24.1	22.5	25.3	28.4	28.1	28.6
	80 Hz	31.5	32.0	27.4	19.5	26.2	27.0	27.7	32.0	31.5	34.2
	100 Hz	36.1	31.3	29.7	24.6	26.5	27.5	31.9	31.3	36.1	36.0
	125 Hz	39.3	37.4	35.2	28.1	29.6	33.7	36.7	37.4	39.3	43.6
	160 Hz	44.3	43.8	40.7	32.2	37.6	39.6	41.8	43.8	44.3	48.8
	200 Hz	49.4	48.6	44.4	36.9	39.5	42.6	46.2	48.6	49.4	51.7
	250 Hz	49.9	49.6	45.5	39.3	42.6	45.5	45.5	49.6	49.9	54.0
	315 Hz	55.0	54.5	48.8	42.4	45.1	47.3	50.3	54.5	55.0	57.3
	400 Hz	57.3	55.0	51.2	45.4	48.3	50.1	52.3	55.0	57.3	58.9
	500 Hz	55.7	55.0	51.7	44.3	48.0	50.6	52.8	55.0	55.7	58.2
	630 Hz	57.7	57.3	53.4	45.9	49.1	52.2	54.6	57.3	57.7	60.1
	800 Hz	58.2	56.5	51.8	44.0	47.9	50.5	53.2	56.5	58.2	59.4
	1000 Hz	59.8	57.0	53.6	48.7	50.7	52.9	54.3	57.0	59.8	60.6
	1250 Hz	55.8	53.5	50.2	42.3	46.2	49.2	51.1	53.5	55.8	57.5
	1600 Hz	54.9	53.6	49.4	41.4	45.2	48.1	50.7	53.6	54.9	57.5
2000 Hz	54.2	52.0	47.7	38.3	42.7	46.0	49.3	52.0	54.2	56.2	
2500 Hz	52.0	50.2	45.4	36.2	39.9	43.7	47.1	50.2	52.0	54.6	
3150 Hz	50.2	48.2	43.1	32.9	37.7	41.1	45.1	48.2	50.2	52.5	
4000 Hz	47.8	45.5	40.3	29.5	34.6	38.5	42.0	45.5	47.8	50.1	
5000 Hz	46.3	43.4	38.6	27.8	32.6	36.7	40.6	43.4	46.3	48.8	
6300 Hz	42.4	39.7	34.3	23.6	28.1	32.3	36.3	39.7	42.4	45.1	
8000 Hz	40.6	37.9	31.7	21.7	25.7	29.5	33.9	37.9	40.6	43.4	
10000 Hz	36.5	33.3	27.3	18.0	21.3	25.0	29.6	33.3	36.5	39.5	
12500 Hz	30.5	26.7	21.1	14.7	16.2	19.2	23.0	26.7	30.5	33.4	
16000 Hz	30.9	31.0	30.6	30.3	30.2	30.4	30.8	31.0	30.9	31.5	

Model		PDWA(3R)-1200-ECM									
speed		H(1350)	M(1250)	L(1100)	800RPM	900RPM	1000RPM	1100RPM	1200RPM	1300RPM	1400RPM
Sound Power dB(A)		66.5	64.4	61.5	52.9	55.8	59.0	61.5	63.3	65.4	67.6
Sound Power in 1/3 Octave-bands under rated ESP (dB)	20 Hz	20.6	21.5	21.6	17.4	17.0	18.0	21.6	22.0	21.1	20.0
	25 Hz	20.0	20.5	22.4	16.9	17.2	15.5	22.4	22.0	19.0	21.0
	31.5 Hz	17.7	17.0	13.5	12.2	14.8	15.3	13.5	16.6	17.3	18.1
	40 Hz	22.2	20.5	17.9	12.3	17.6	14.8	17.9	18.9	22.2	22.2
	50 Hz	24.7	23.9	17.4	14.2	15.8	18.2	17.4	23.1	24.7	24.6
	63 Hz	30.0	29.2	24.7	18.8	20.5	19.7	24.7	29.2	29.2	30.9
	80 Hz	33.1	32.5	28.8	19.6	25.0	24.0	28.8	30.8	34.1	32.2
	100 Hz	37.3	34.8	34.3	24.7	28.4	29.2	34.3	33.5	36.1	38.5
	125 Hz	43.7	41.7	39.1	31.3	33.2	37.3	39.1	40.4	42.9	44.4
	160 Hz	48.1	45.2	42.8	34.8	38.7	41.4	42.8	44.6	45.8	50.5
	200 Hz	50.7	48.7	44.4	36.0	38.4	42.9	44.4	47.1	50.4	51.0
	250 Hz	50.6	49.6	45.2	37.5	39.8	43.1	45.2	49.5	49.8	51.4
	315 Hz	55.7	53.8	50.3	42.2	45.1	47.8	50.3	52.4	55.1	56.3
	400 Hz	57.4	55.5	52.4	45.2	47.3	49.4	52.4	54.5	56.5	58.3
	500 Hz	57.0	55.3	52.2	44.1	47.6	50.0	52.2	54.0	56.7	57.3
	630 Hz	56.4	54.8	51.3	43.7	46.4	50.2	51.3	54.3	55.2	57.5
	800 Hz	56.5	54.7	51.6	43.4	46.4	49.7	51.6	54.0	55.5	57.6
	1000 Hz	56.5	54.9	51.5	43.0	46.8	49.5	51.5	54.6	55.2	57.8
	1250 Hz	54.9	53.1	50.0	40.3	44.5	47.7	50.0	52.1	54.0	55.8
	1600 Hz	55.0	53.1	50.0	39.5	43.8	46.7	50.0	52.1	54.1	55.9
2000 Hz	54.8	52.3	49.0	37.0	41.6	45.1	49.0	51.1	53.4	56.1	
2500 Hz	52.9	50.5	46.4	34.2	39.1	42.9	46.4	49.1	51.8	54.0	
3150 Hz	51.0	48.5	43.9	31.1	36.4	40.2	43.9	47.1	49.8	52.1	
4000 Hz	47.7	44.9	40.0	26.8	31.8	36.1	40.0	43.4	46.3	49.2	
5000 Hz	44.8	41.8	36.8	23.6	28.1	32.6	36.8	40.2	43.3	46.3	
6300 Hz	40.8	37.5	32.1	21.1	24.3	28.3	32.1	35.7	39.3	42.4	
8000 Hz	38.5	35.2	30.3	23.0	24.5	27.2	30.3	33.5	36.9	40.1	
10000 Hz	33.9	30.1	24.2	17.3	18.4	20.7	24.2	28.2	32.0	35.7	
12500 Hz	27.8	24.1	19.2	15.8	16.2	17.0	19.2	22.3	26.0	29.7	
16000 Hz	35.0	35.5	36.6	36.0	36.5	36.3	36.6	36.0	35.0	34.9	

Model		PDWA(3R)-1400-ECM										
speed		H(1350)	M(1250)	L(1100)	700RPM	800RPM	900RPM	1000RPM	1100RPM	1200RPM	1300RPM	1400RPM
Sound Power dB(A)		68.4	66.6	61.5	52.5	55.4	58.4	61.5	63.1	65.7	67.5	69.3
Sound Power in 1/3 Octave-bands under rated ESP (dB)	20 Hz	12.9	15.5	19.2	17.4	19.6	20.2	19.2	16.6	19.2	11.8	14.0
	25 Hz	15.2	14.7	20.4	21.4	15.4	21.5	20.4	16.7	16.2	13.2	17.3
	31.5 Hz	14.7	16.8	20.4	15.2	16.0	14.6	20.4	19.0	17.6	16.0	13.5
	40 Hz	19.2	19.8	16.2	10.8	12.2	10.8	16.2	18.9	20.1	19.5	18.8
	50 Hz	22.2	20.1	16.3	10.4	18.1	13.9	16.3	15.7	19.0	21.2	23.2
	63 Hz	28.8	28.6	27.9	17.4	19.8	27.4	27.9	25.7	27.0	30.2	27.5
	80 Hz	35.5	33.7	30.2	20.0	21.7	25.4	30.2	28.9	32.0	35.5	35.5
	100 Hz	38.4	35.7	34.0	22.6	23.9	27.5	34.0	32.9	34.5	36.9	39.8
	125 Hz	45.1	44.2	37.5	27.7	32.3	35.3	37.5	41.6	43.3	45.1	45.1
	160 Hz	50.7	48.5	43.5	34.6	38.2	39.6	43.5	45.2	47.7	49.2	52.2
	200 Hz	52.7	50.2	45.8	34.6	39.3	42.2	45.8	48.0	48.3	52.0	53.4
	250 Hz	56.0	53.7	47.5	36.9	40.4	44.5	47.5	49.2	51.8	55.6	56.5
	315 Hz	57.7	55.2	50.5	40.8	44.1	46.9	50.5	52.2	53.4	57.0	58.4
	400 Hz	60.1	58.0	53.7	47.1	48.0	50.6	53.7	54.8	57.2	58.8	61.3
	500 Hz	59.1	57.4	53.1	45.3	48.0	51.4	53.1	54.2	57.1	57.6	60.6
	630 Hz	56.9	55.5	50.7	41.9	44.9	48.3	50.7	52.5	55.0	56.0	57.9
	800 Hz	60.8	59.0	54.4	43.8	47.5	50.9	54.4	55.1	57.6	60.3	61.2
	1000 Hz	57.6	55.6	50.0	39.6	43.9	47.4	50.0	52.2	55.0	56.3	58.8
1250 Hz	56.4	54.6	48.7	38.5	42.4	45.8	48.7	50.5	53.5	55.7	57.0	
1600 Hz	55.4	53.4	47.3	36.4	40.5	44.1	47.3	49.9	52.2	54.6	56.2	
2000 Hz	54.0	51.9	45.9	35.2	39.0	42.7	45.9	48.2	50.9	52.9	55.2	
2500 Hz	53.3	51.4	44.7	32.3	37.6	41.7	44.7	47.5	50.5	52.4	54.2	
3150 Hz	53.8	51.7	44.6	31.2	36.8	41.0	44.6	47.3	50.5	52.9	54.8	
4000 Hz	51.7	49.5	42.0	28.4	34.0	38.2	42.0	45.0	48.3	50.7	52.7	
5000 Hz	49.3	46.9	39.0	25.0	30.9	35.1	39.0	42.1	45.8	47.9	50.7	
6300 Hz	46.4	43.8	36.3	22.1	26.7	31.3	36.3	39.1	42.4	45.2	47.6	
8000 Hz	44.5	42.0	32.5	19.1	23.4	28.0	32.5	36.8	40.7	43.4	45.6	
10000 Hz	41.7	38.5	28.2	16.3	19.2	23.5	28.2	31.9	36.7	40.4	43.1	
12500 Hz	35.5	31.9	21.9	14.2	15.4	18.3	21.9	25.4	30.0	33.8	37.2	
16000 Hz	32.9	32.7	33.3	32.8	32.7	32.7	33.3	32.4	32.4	32.9	32.9	

Model		PDWA(3R)-1600-ECM											
speed		H(1350)	M(1250)	L(1100)	600RPM	700RPM	800RPM	900RPM	1000RPM	1100RPM	1200RPM	1300RPM	1400RPM
Sound Power dB(A)		70.2	68.1	65.0	48.5	52.6	56.6	60.0	62.6	65.0	67.1	69.1	71.2
Sound Power in 1/3 Octave-bands under rated ESP (dB)	20 Hz	14.6	15.1	17.0	7.7	15.9	13.8	14.3	16.4	17.0	15.1	15.1	14.1
	25 Hz	21.7	20.2	11.9	9.9	14.6	14.0	8.5	17.1	11.9	16.5	23.8	19.6
	31.5 Hz	19.4	16.9	10.2	11.8	10.0	8.2	12.5	13.9	10.2	16.0	17.8	21.1
	40 Hz	20.9	21.3	11.8	12.9	9.0	10.1	14.4	15.3	11.8	19.2	23.4	18.4
	50 Hz	24.0	22.8	21.0	9.9	13.9	15.4	15.6	17.8	21.0	22.3	23.3	24.8
	63 Hz	32.2	28.3	32.2	13.8	18.4	16.9	20.8	28.1	32.2	25.5	31.2	33.1
	80 Hz	36.7	34.6	31.2	17.5	19.8	19.8	24.9	28.8	31.2	33.8	35.3	38.1
	100 Hz	39.6	36.2	36.8	18.4	23.1	26.3	30.2	33.1	36.8	33.8	38.5	40.6
	125 Hz	44.7	43.7	41.5	23.4	27.9	31.9	34.9	37.4	41.5	44.0	43.5	45.8
	160 Hz	50.6	49.3	46.5	28.9	32.9	37.0	40.7	42.7	46.5	48.9	49.6	51.7
	200 Hz	53.6	50.9	48.8	31.2	36.7	39.5	43.9	46.8	48.8	49.9	52.0	55.2
	250 Hz	56.3	53.8	51.5	33.7	40.0	42.1	46.4	48.2	51.5	53.5	54.1	58.5
	315 Hz	58.0	56.6	54.0	36.7	41.9	45.1	49.0	50.5	54.0	56.3	56.8	59.2
	400 Hz	58.8	56.6	53.1	38.6	42.2	45.6	48.7	51.1	53.1	56.0	57.1	60.6
	500 Hz	60.0	58.2	56.3	42.0	46.1	48.3	51.9	53.8	56.3	57.0	59.3	60.7
	630 Hz	60.6	58.7	55.3	40.7	44.9	47.7	50.5	53.0	55.3	57.4	60.0	61.2
	800 Hz	60.7	58.9	55.2	39.2	43.6	47.2	51.5	53.2	55.2	57.7	60.2	61.2
	1000 Hz	61.6	59.4	56.2	38.8	44.4	47.1	50.9	53.5	56.2	57.6	61.1	62.0
1250 Hz	59.9	57.8	54.5	36.0	41.1	44.9	48.8	51.2	54.5	56.9	58.8	61.1	
1600 Hz	59.4	57.4	53.4	34.1	39.6	43.9	48.1	51.0	53.4	56.2	58.5	60.3	
2000 Hz	57.1	55.1	51.2	30.7	36.7	41.1	45.2	47.9	51.2	53.9	56.3	57.8	
2500 Hz	55.6	53.2	49.3	28.0	34.3	38.6	42.7	46.2	49.3	51.6	54.7	56.6	
3150 Hz	54.8	52.4	48.6	26.3	32.5	37.2	41.8	45.1	48.6	50.9	53.9	55.7	
4000 Hz	53.3	50.9	47.0	23.9	30.2	34.9	39.4	43.5	47.0	49.5	52.3	54.3	
5000 Hz	51.7	49.2	45.5	21.1	28.0	33.0	37.7	41.6	45.5	47.8	50.5	52.9	
6300 Hz	49.0	46.5	43.0	18.5	24.0	29.0	34.6	39.0	43.0	45.1	47.8	50.2	
8000 Hz	47.3	44.8	40.7	16.5	20.3	25.4	31.5	36.3	40.7	43.3	46.2	48.3	
10000 Hz	44.7	42.0	37.2	14.3	17.0	21.2	27.2	32.1	37.2	40.4	43.5	45.9	
12500 Hz	39.4	36.0	30.8	11.9	13.3	15.9	21.0	25.4	30.8	34.1	38.0	40.8	
16000 Hz	34.0	33.4	33.3	30.5	31.4	32.0	32.9	33.4	33.3	33.3	33.5	34.4	

A.5. Dimensional Drawings

A.5.1. 2-pipe

A.5.1.1. Dimensional drawings for PDWA(3R)/ PDWA(4R)/ PDWA(6R)

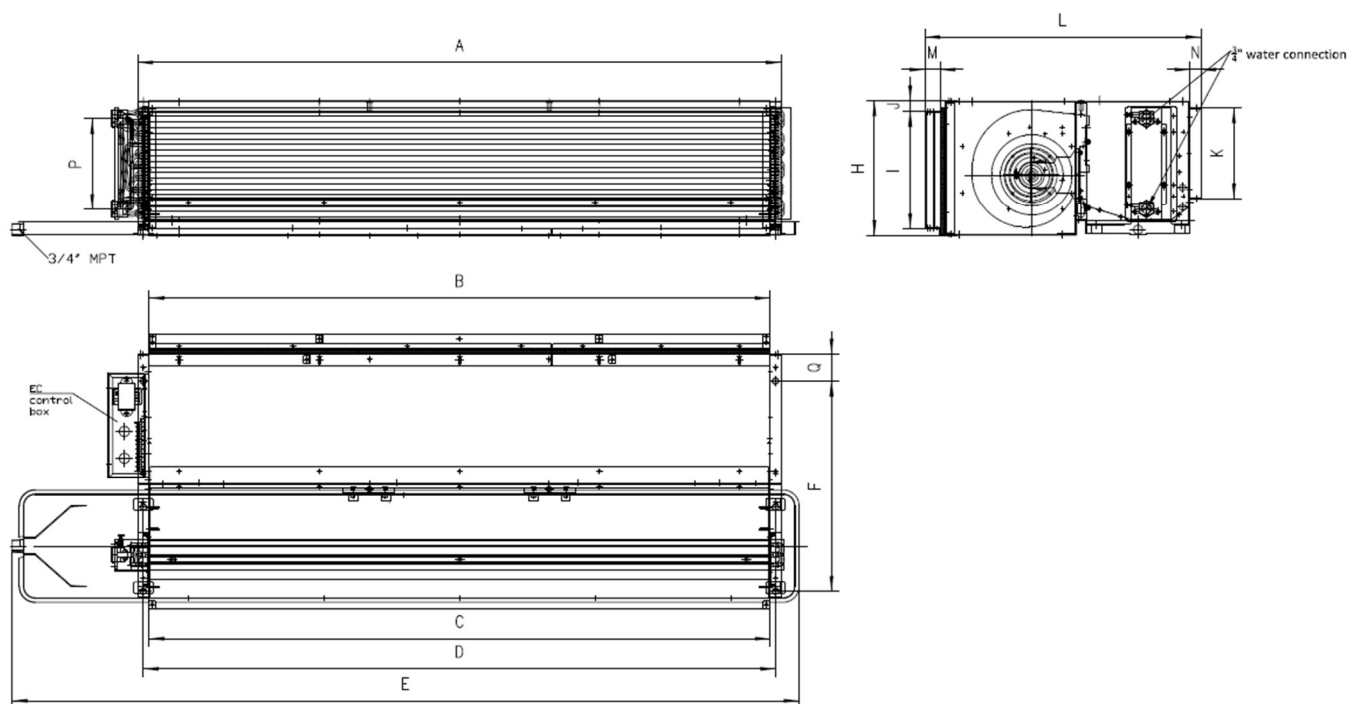

A.5.1.2. Dimensions for PDWA(3R)/ PDWA(4R)

Model	A	B	C	D	E	F	G	H
PDWA-200	535	485	485	510	755	400	φ14	250
PDWA-300	635	585	585	610	855	400	φ14	250
PDWA-400	735	685	685	710	955	400	φ14	250
PDWA-500	835	785	785	810	1055	400	φ14	250
PDWA-600	935	885	885	910	1155	400	φ14	250
PDWA-800	1335	1285	1285	1310	1555	400	φ14	250
PDWA-1000	1435	1385	1385	1410	1655	400	φ14	250
PDWA-1200	1575	1525	1525	1550	1795	400	φ14	250
PDWA-1400	1435	1385	1385	1410	1655	470	φ14	300
PDWA-1600	1695	1645	1645	1670	1915	470	φ14	300

Model	I	J	K	L	M	N	P	Q
PDWA-200	213	25	153	546	35	25	152	60
PDWA-300	213	25	153	546	35	25	152	60
PDWA-400	213	25	153	546	35	25	152	60
PDWA-500	213	25	153	546	35	25	152	60
PDWA-600	213	25	153	546	35	25	152	60
PDWA-800	213	25	153	546	35	25	152	60
PDWA-1000	213	25	153	546	35	25	152	60
PDWA-1200	213	25	153	546	35	25	152	60
PDWA-1400	263	25	203	616	35	25	202	60
PDWA-1600	263	25	203	616	35	25	202	60

A.5.1.3. Dimensions for PDWA(6R)

Model	A	B	C	D	E	F	G	H
PDWA-200	535	485	485	510	755	444	φ14	250
PDWA-300	635	585	585	610	855	444	φ14	250
PDWA-400	735	685	685	710	955	444	φ14	250
PDWA-500	835	785	785	810	1055	444	φ14	250
PDWA-600	935	885	885	910	1155	444	φ14	250
PDWA-800	1335	1285	1285	1310	1555	444	φ14	250
PDWA-1000	1435	1385	1385	1410	1655	444	φ14	250
PDWA-1200	1575	1525	1525	1550	1795	444	φ14	250
PDWA-1400	1435	1385	1385	1410	1655	514	φ14	300
PDWA-1600	1695	1645	1645	1670	1915	514	φ14	300

Model	I	J	K	L	M	N	P	Q
PDWA-200	213	25	153	590	35	25	152	60
PDWA-300	213	25	153	590	35	25	152	60
PDWA-400	213	25	153	590	35	25	152	60
PDWA-500	213	25	153	590	35	25	152	60
PDWA-600	213	25	153	590	35	25	152	60
PDWA-800	213	25	153	590	35	25	152	60
PDWA-1000	213	25	153	590	35	25	152	60
PDWA-1200	213	25	153	590	35	25	152	60
PDWA-1400	263	25	203	660	35	25	202	60
PDWA-1600	263	25	203	660	35	25	202	60

(All dimensions shown in mm)

A.5.2. 4-pipe

A.5.2.1. Dimensional Drawings For PDWA(3R+1)/ PDWA(3R+2)/ PDWA(4R+2)

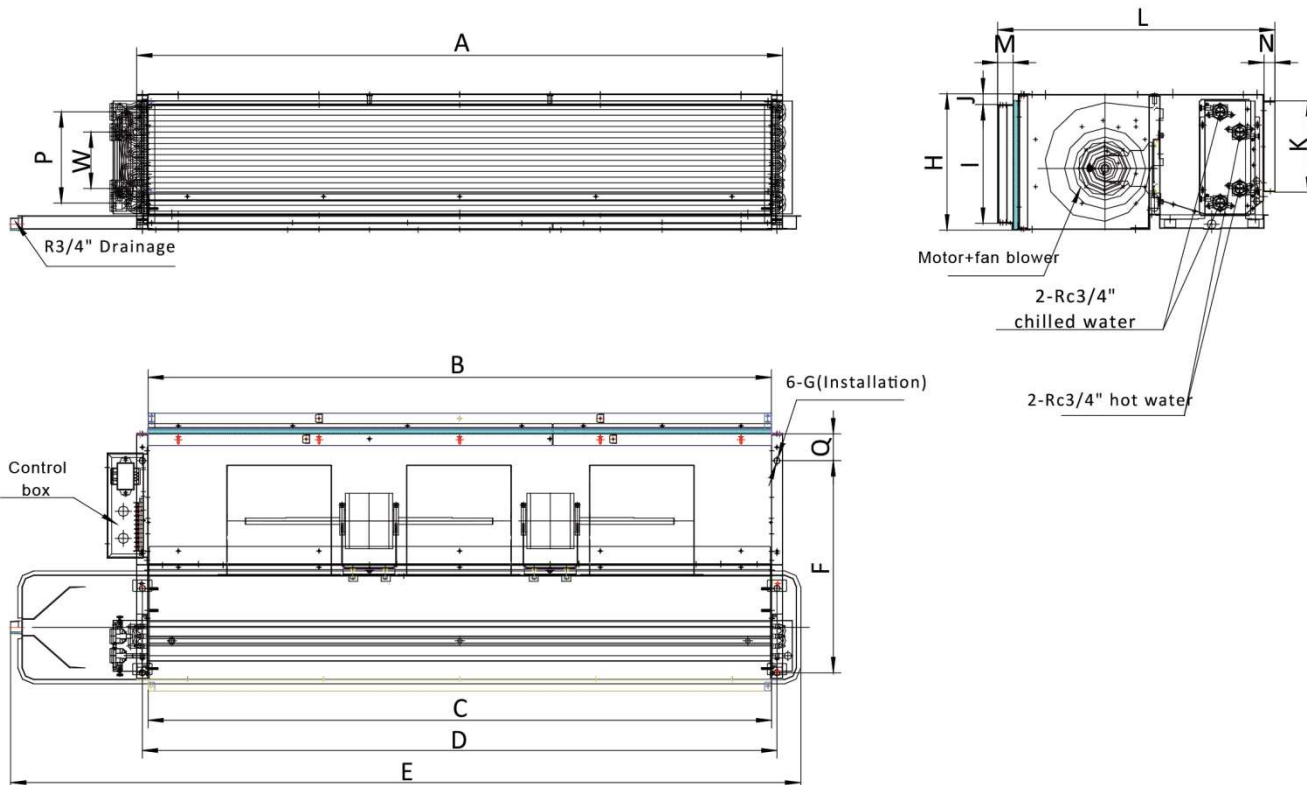

A.5.2.2. Dimensions for PDWA(3R+1)

Model	A	B	C	D	E	F	G	H
PDWA-200	535	485	485	510	755	400	φ14	250
PDWA-300	635	585	585	610	855	400	φ14	250
PDWA-400	735	685	685	710	955	400	φ14	250
PDWA-500	835	785	785	810	1055	400	φ14	250
PDWA-600	935	885	885	910	1155	400	φ14	250
PDWA-800	1335	1285	1285	1310	1555	400	φ14	250
PDWA-1000	1435	1385	1385	1410	1655	400	φ14	250
PDWA-1200	1575	1525	1525	1550	1795	400	φ14	250
PDWA-1400	1435	1385	1385	1410	1655	470	φ14	300
PDWA-1600	1695	1645	1645	1670	1915	470	φ14	300

Model	I	J	K	L	M	N	P	Q	W
PDWA-200	213	25	153	546	35	25	152	60	75
PDWA-300	213	25	153	546	35	25	152	60	75
PDWA-400	213	25	153	546	35	25	152	60	75
PDWA-500	213	25	153	546	35	25	152	60	75
PDWA-600	213	25	153	546	35	25	152	60	75
PDWA-800	213	25	153	546	35	25	152	60	75
PDWA-1000	213	25	153	546	35	25	152	60	75
PDWA-1200	213	25	153	546	35	25	152	60	75
PDWA-1400	263	25	203	616	35	25	202	60	125
PDWA-1600	263	25	203	616	35	25	202	60	125

A.5.2.3. Dimensions for PDWA(3R+2)/PDWA(4R+2)

Model	A	B	C	D	E	F	G	H
PDWA-200	535	485	485	510	755	444	φ14	250
PDWA-300	635	585	585	610	855	444	φ14	250
PDWA-400	735	685	685	710	955	444	φ14	250
PDWA-500	835	785	785	810	1055	444	φ14	250
PDWA-600	935	885	885	910	1155	444	φ14	250
PDWA-800	1335	1285	1285	1310	1555	444	φ14	250
PDWA-1000	1435	1385	1385	1410	1655	444	φ14	250
PDWA-1200	1575	1525	1525	1550	1795	444	φ14	250
PDWA-1400	1435	1385	1385	1410	1655	514	φ14	300
PDWA-1600	1695	1645	1645	1670	1915	514	φ14	300

Model	I	J	K	L	M	N	P	Q	W
PDWA-200	213	25	153	590	35	25	152	60	75
PDWA-300	213	25	153	590	35	25	152	60	75
PDWA-400	213	25	153	590	35	25	152	60	75
PDWA-500	213	25	153	590	35	25	152	60	75
PDWA-600	213	25	153	590	35	25	152	60	75
PDWA-800	213	25	153	590	35	25	152	60	75
PDWA-1000	213	25	153	590	35	25	152	60	75
PDWA-1200	213	25	153	590	35	25	152	60	75
PDWA-1400	263	25	203	660	35	25	202	60	125
PDWA-1600	263	25	203	660	35	25	202	60	125

(All dimensions shown in mm)

B. Installation

B.1. Safety Precautions

- When installing, performing maintenance or servicing Polar Air fan coil units observe the precautions stated in this manual as well as those stated on the labels attached to the unit.
- Ensure all local and national safety codes, laws, regulations, as well as general electrical and mechanical safety guidelines are followed for installation, maintenance and service.
- The appliance is for indoor use only.
- Ensure the correct power supply is provided.
- If the power supply cord is damaged, it must be replaced by qualified personnel.
- Installing and servicing fan coil unit should be performed by qualified service personnel only.
- This appliance is not intended for use by persons (including children) with reduced physical, sensory or mental capabilities, or persons lacking in experience and knowledge of the appliance, unless they have been given supervision or instruction concerning it.
- User of this appliance is responsible for his/her own safety.
- Warranty shall be voided if installation instructions and safety precaution stated in this manual are not observed.
- Never cut off the mains supply when unit is under operation. The unit should only be switched off by using the ON-OFF button on the control interface.
- During connections, select pipe pliers according to pipe diameter to avoid damaging units over forced.
- Untreated frozen water and cooling water may cause dirt accumulation and corrosion. Suggest using treated water. Suggested working water pressure is below 1.6 Mpa.
- When units are in cooling mode, suggested freezing water degree is $\geq 7^{\circ}\text{C}$; When units are in heating mode, suggested hot water degree is $\leq 60^{\circ}\text{C}$.
- Condensate water pipe, water connection pipe, water connectors and solenoid valve body must remain heat to avoid condensation.

CAUTIONS

Before any service or maintenance operations turn off the mains electrical supply.

DO NOT turn OFF the main power supply when the unit is operating. Turn off the unit BEFORE turning off the main power

B.2. Location

- Confirm there is enough space for unit installation and maintenance. Please refer to below figure for the unit's outlines and dimensions and for the minimum distance between the unit and the obstacle/ any obstructions/ its surroundings.
- Ensure there is enough space for piping connections and electrical wiring.
- Check whether the hanging rods can support the weight of the unit (see specification table for weight of the unit).
- Confirm the unit is installed horizontally to ensure proper operation and condensate draining.
- Confirm that the unit has been switched OFF before installing or servicing the unit.
- Confirm the filter is in place and clean. Replace filter if required.
- Confirm the installation procedures below were followed.

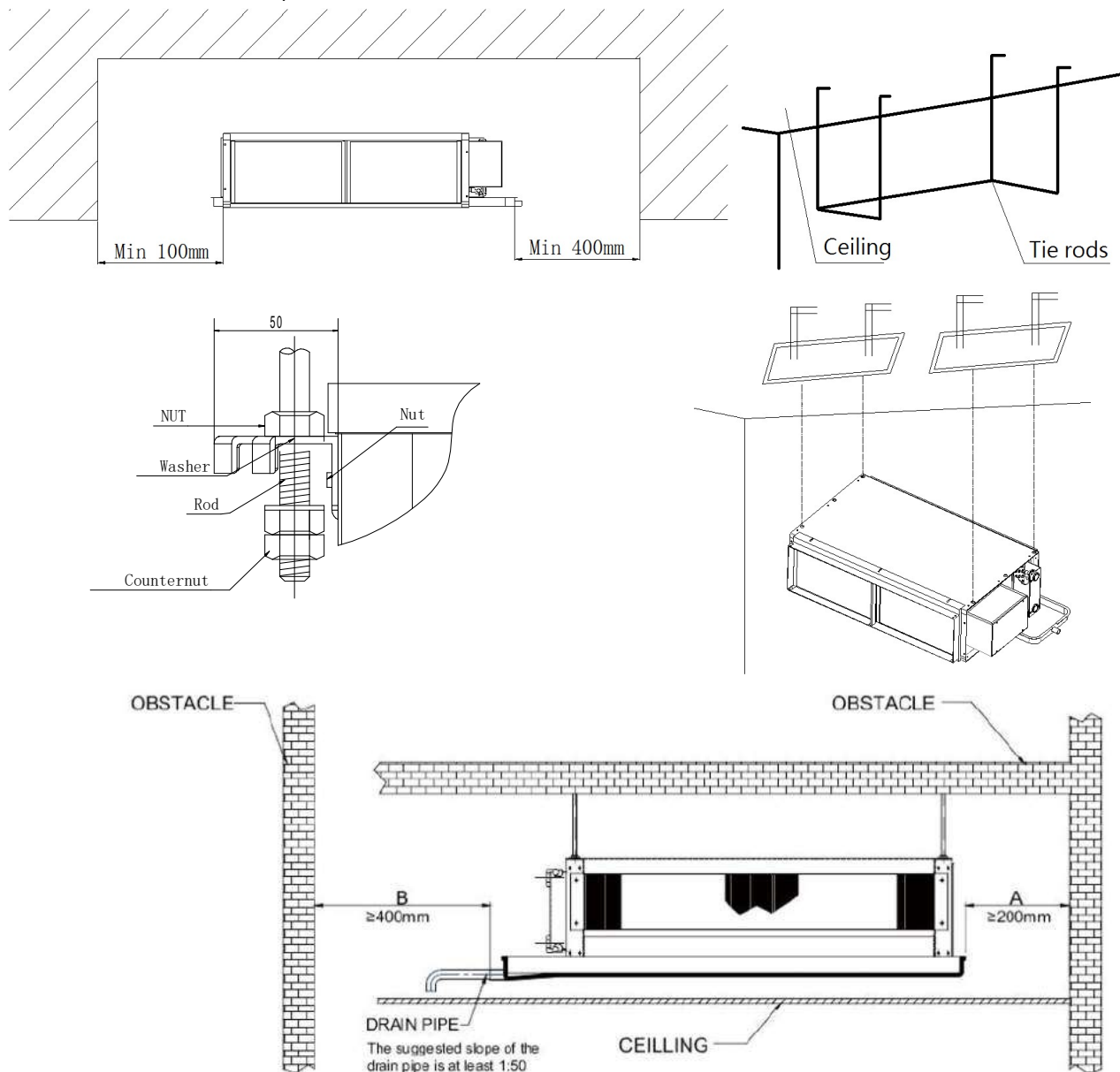

CAUTION

Make sure the top of the unit is level after installation. The drain pan is designed with a slight gradient to facilitate drainage.

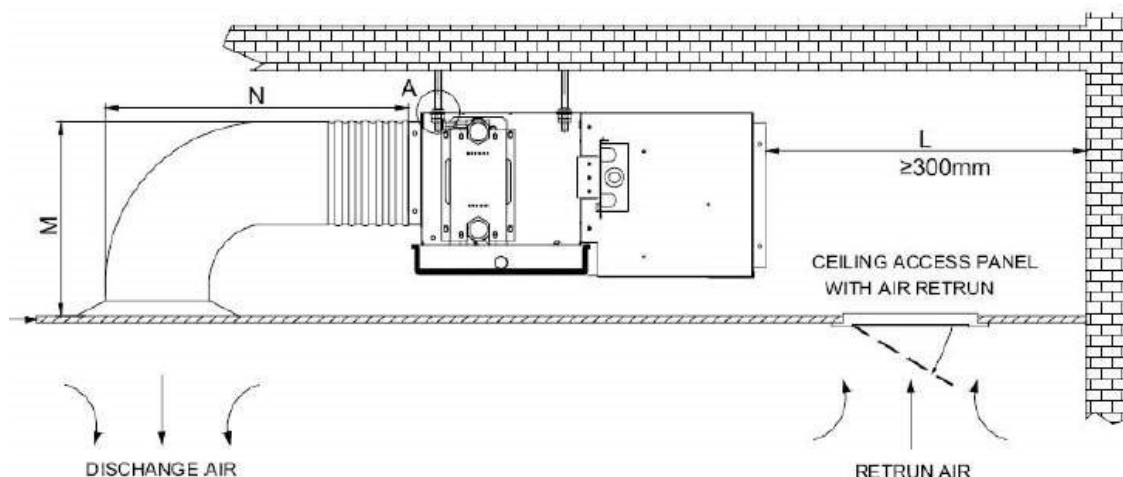
**CAUTIONS**

Dimension M and N are determined by air duct design.

Air duct should be fire-proof. Please refer to concerned country national and local regulation.

Circulatory air pressure drop should be approximately equal to the External Static Pressure.

B.3. Insulation

- Confirm the Chilled water pipes and all parts on the pipes are insulated.
- Confirm insulation is installed on the supply air duct.

B.4. Service Connection

- Confirm duct connections are sealed.
- Confirm water piping INLET is at the BOTTOM, water OUTLET is at the TOP.
- Confirm no water leakage is observed at the piping and condensate drain connections.
- Confirm drain pipe slope is minimum 1:50.

Caution

When connecting pipe to fan coil unit, do not bend or reposition the coil header for alignment purposes. This could cause a tubing fracture resulting in a water leak when water pressure is applied to the system.

B.5. Electrical Connection

- Confirm wiring connection is done according to the wiring diagram on the unit.
- Confirm the unit is GROUNDED properly.
- Confirm an appropriate strain relief device is used to attach the power wires to the terminal box.
- Confirm a main disconnect switch is incorporated in the fixed wiring in accordance with the relevant local and national legislation.
- Confirm the speed Setting: LOW, MED, HIGH.
- Confirm the controller wiring is adjusted to the correct terminals LOW: G0, MED: G1, HIGH: G2.

B.6. Unit Operation

- Confirm air has been properly bled from and there is waterflow through the coil.
- Confirm fan wheel is rotating and air is discharged at unit supply opening
- Confirm power voltage between Terminals L1 and N.
- Confirm thermostat voltage (if equipped).
- Verify desired fan speed is receiving power from the thermostat.
- Check functionality of motor with a call for heating or cooling.
- Confirm system ESP is per schedule.
- Confirm control valve(s) functionality.

C. Maintenance

C.1. General Maintenance

1. Installation and maintenance should be performed by qualified personnel who are familiar with local codes and regulations, and are also experienced with this type of appliance.
2. Confirm the unit has been switched OFF before installing or servicing the unit.
3. A good general maintenance plan will prevent damage to and unexpected shutting down of the equipment.
4. Dirty filters reduce air flow as well as unit performance. Therefore, changing or cleaning the filters is very important. Check the cleanliness of the filter and replace or clean as required monthly.
5. Coils should be cleaned with compressed air or water to remove dust, dirt or lint. They can be brushed with a soft brush or vacuumed with a vacuum cleaner.
6. If the water coil is not being used during the winter season it should be drained, or an anti-freezing solution should be added to the water circuit to avoid freezing.

C.2. Regular Maintenance

1. Inspect and clean the condensate drain pan to avoid any clogging of the drain by dirt, dust, etc. Inspect drainage piping to ensure the proper condensate flow.
2. Check and clean the coil. Clean the coils with a low-pressure water jet or low-pressure air.
3. Clean and tighten all the wiring connections.
4. Drain out the water system and check for buildup of mineral deposits.

C.3. Filter Cleaning

1. Remove the filter from bottom or side.
2. Clean the filter with a brush, or with water.
3. Replace the filter by sliding it back into the groove.

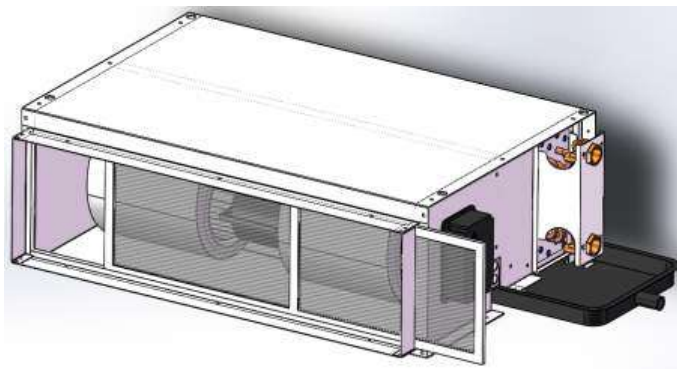
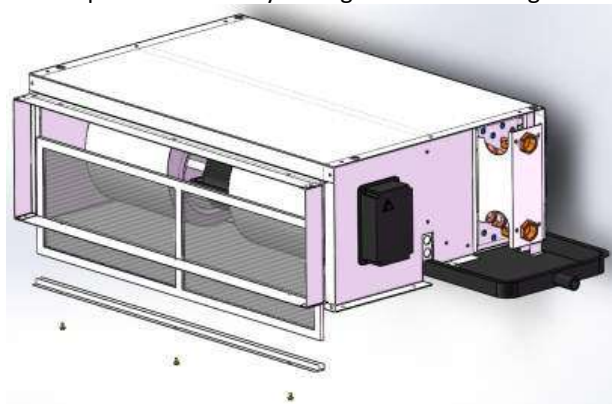

C.4. Fan Motor Assembly Maintenance

1. Remove the screws from the bottom panel.
2. Remove 4 screws from both sides of the unit.
3. The complete fan-motor assembly can then be taken out easily.

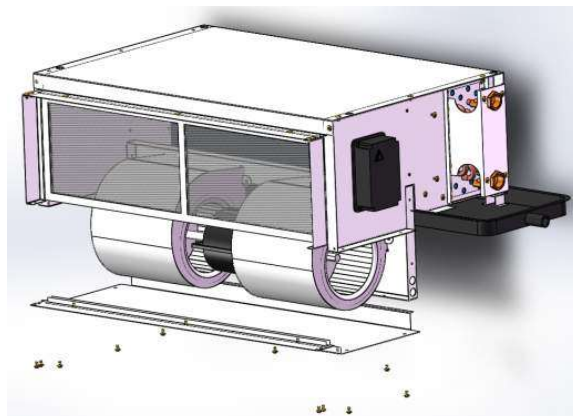

C.5. Coil Direction Interchange

1. Remove 4 screws for to remove the drain pan.
2. Remove 6 screws on both sides to remove drain guide.
3. Remove 4 screws on both side of coil mounting brackets.
4. The complete coil assembly can be taken out easily.
5. If the coil direction is exchanged on site, water inlet and water outlet need to be exchanged. After interchanged, the upper is water inlet and the bottom is water outlet.

Note: Coil direction interchange may change the coil performance.

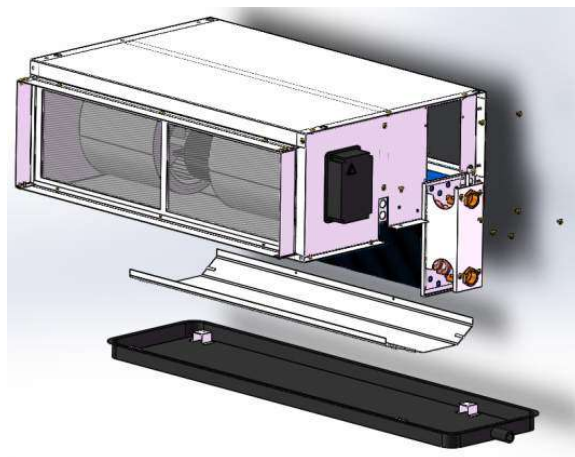

C.6. Electric Heater Replacement

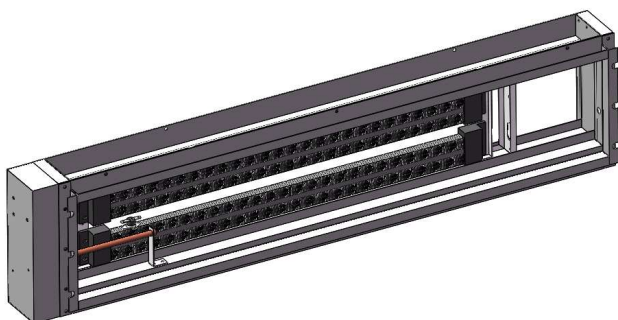

1. Unscrew the old PDWA-EH module from the unit. Prepare a new PDWA-EH module.



2. Remove PDWA discharge flange and install it on the EH module. (Skip this step if no removable flange.)

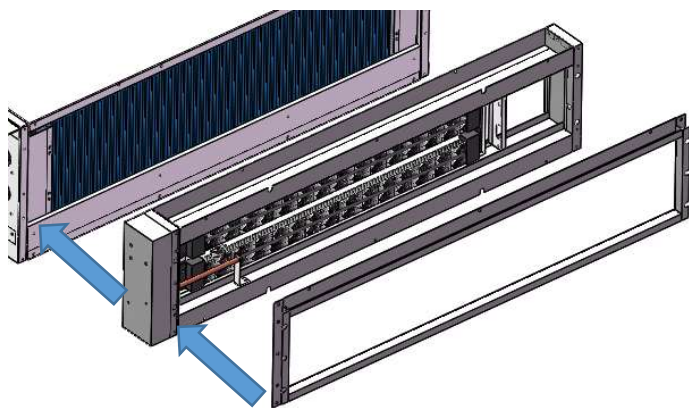

3. Screw PDWA discharge flange onto EH module and then install the EH module to the unit.

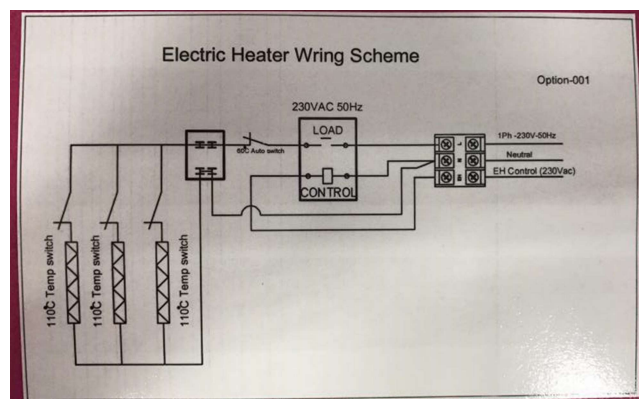

4. Connect "L" & "N" ports to PDWA terminal "L" & "N" connected to 230V/1Ph power supply. Connect "EH" port to related terminal on PDWA which is control signal from thermostat or S-type control board.

D. Control Specifications: Intelligent Control (I Type)

D.1. I/O Port Definitions

I/O		Code	Description
Analogue Input	Return air sensor	AI1	Return air temperature (Tr)
	2-pipe coil circuit sensor	AI2	Water inlet temperature sensor (Ti1)
	Hot water Sensor	AI3	Water outlet temperature sensor (Ti2)
Input	LED display / IR receiver	X-DIS 1	Digital communication port to LED display/IR receiver board.
	Wired wall pad	TTL1	Digital communication port to wired wall-pad board.
Digital input	Occupancy contact	ON/OFF	NO/NC contact by setting
	Float switch	Float	Voltage-free (NC). The contact is connected with float switch (NC);
	Electrical heater safety switch	EH	Voltage-free (NC). The contact is connected with E-heater safeties.
Power input	Phase	L1	Power supply to the PCB;
	Neutral	N1	Power supply to the PCB;
	Earth	PE1	Power supply to the PCB;
Voltage output	Fan 1	CN4	Fan 1 driver and motor connection port.
	Fan2	CN5	Fan 2 driver and motor connection port.
	Valve1	MTV1	On/off valve
	Valve2	MTV2	On/off valve
	Water pump	PUMP	Condensate pump signal output.
	Voltage of electrical heater (Live)	L-EH	Voltage output (L), maximum 30A..
Output	Auxiliary contact 1	AUX1	Cooling mode signal relay (NO). Voltage free contact.
	Auxiliary contact 2	AUX2	Heating mode signal switch (NO). Voltage free contact.
	Serial BUS port (S3 type)	AB	Terminals for local network serial connection
	24VAC power input	DA1	24VAC external power supply (modulating valve applications only).
	Modulating valve 1	DA2	0~10Vdc
	Modulating valve 2	DA3	0~10Vdc

D.2. Wiring Diagram
Standard EC-S3 Control PCB

EC-iS3 Wiring Scheme

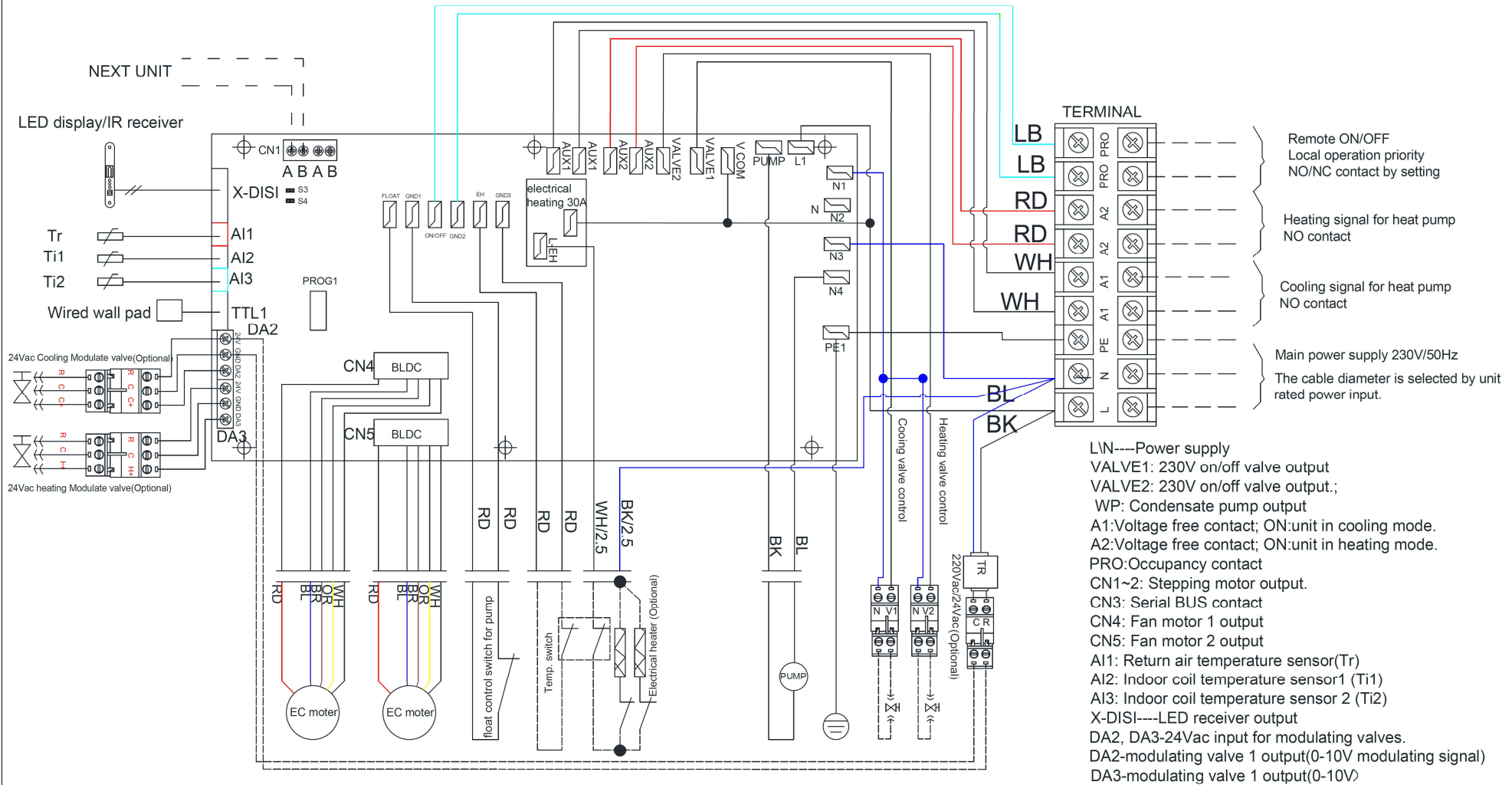

TR transformer is optional.

D.2.1. Fan Coil Unit ON/OFF

There are 3 ways to turn the system on or off:

- a) By the ON/OFF button on the remote handset or wired wall pad.
- b) By the programmable timer on the handset or wired wall pad.
- c) By the manual control button on the fan coil unit.

D.2.2. Auto Restart

The system uses a non-volatile memory to save the present operation parameters when the system is turned off or in case of system failure or cessation of power supply.

The restored parameter data-set depends on the type of user interface.

- a) Handset only user interface:

When the power ON signal is received by the air conditioner and no wired wall-pad is installed, the Mode, Fan Speed, Set temperature will be the same as the handset setting before the last power OFF.

- b) Wall-pad only OR wall-pad and handset user interface:

When the power ON signal is received by the air conditioner and a wired wall-pad is installed, the Mode, Fan Speed, Set temperature and Timer ON/OFF weekly program will be the same as the wall pad setting before the last power OFF.

D.3. Control Logics for 2-Pipe System

D.3.1. With Modulating Valve Configuration

COOL MODE

When unit is turned on in cooling mode.

If $T_r \geq T_s + 1^\circ\text{C}$ (Modbus 300033 setting), MTV1 is turned on. AUX1 is closed. Fan is turned on at setting speed. DA2 is turned on at 10 VDC for 2 minutes, then check Ti1:

- When $T_{i1} \leq 8^\circ\text{C}$, DA2 output is based on water temperature difference (T_{i1}/T_{i2}) and Modbus parameter 300027 setting PID calculation. The output is minimum output (Modbus300015 setting) ~10 VDC.
- When $8 < T_{i1} \leq 10^\circ\text{C}$, DA2 output is based on water temperature difference (T_{i1}/T_{i2}) and Modbus parameter 300027 setting minus 1 PID calculation. The output is minimum output (Modbus300015 setting) ~10 VDC.
- When $10 < T_{i1} \leq 12^\circ\text{C}$, DA2 output is based on water temperature difference (T_{i1}/T_{i2}) and Modbus parameter 300027 setting minus 2 PID calculation. The output is minimum output (Modbus300015 setting) ~10 VDC.
- When $12 < T_{i1} \leq 15^\circ\text{C}$, DA2 output is based on water temperature difference (T_{i1}/T_{i2}) and Modbus parameter 300027 setting minus 3 PID calculation. The output is minimum output (Modbus300015 setting) ~10 VDC.
- When $15 < T_{i1} \leq 28^\circ\text{C}$ (Modbus 300017 setting), DA2 output is kept at 10 VDC.
- When $T_{i1} > 28^\circ\text{C}$ (Modbus 300017 setting), DA2 output is at minimum (Modbus300016 setting) and report pre-heat alarm.
- If $T_r < T_s - 1^\circ\text{C}$ (Modbus 300033 setting), then cool operation is terminated and MTV1 and AUX1 are turned off. Indoor fan runs at set speed. DA2 output is 0 VDC.
- When unit is turned off, MTV1 and AUX1 are off. DA2 is 0 VDC. Fan is turned off delaying 30s.
- The range of T_s is 16 - 30°C
- Indoor fan speed can be adjusted to low, medium, high and auto.

LOW TEMPERATURE PROTECTION OF INDOOR COIL IN COOLING MODE

If $T_{i1} \leq 2^\circ\text{C}$ for 2 minutes

- MTV1 is turned OFF,
- DA2 is set to 0%,
- Indoor fan is turned on to Medium speed if fan runs at low speed.

If $T_{i1} \geq 5^\circ\text{C}$ for 2 minutes

- MTV1 is turned ON,
- DA2 is set to original status,
- Indoor fan is changed to setting speed

FAN MODE

Indoor fan speed can be adjusted for low, medium and high. If fan speed is set auto by Modbus, fan is running at low speed.

HEAT MODE

Without Electrical Heater (Modbus300047=0)

When unit is turned on in heating mode.

When $T_r \leq T_s - 1^\circ\text{C}$ (Modbus 300033 setting), MTV1 and AUX2 is turned on. DA2 is at 10 VDC for 2 minutes, then check Ti1:

- If $T_{i1} < 28^\circ\text{C}$ (Modbus 300017 setting), fan is turned on at low speed. DA2 is at 10 VDC.
- If $28^\circ\text{C} < T_{i1} < 28 + 4^\circ\text{C}$ (Modbus 300017 setting) +4°C, fan is on at original state. DA2 is at original state.
- If $T_{i1} \geq 28 + 4^\circ\text{C}$ (Modbus 300017 setting) +4°C, fan is on at setting speed. DA2 output is based on water temperature difference (T_{i1}/T_{i2}) and Modbus parameter 300028 setting PID calculation. The output is minimum output (Modbus300015 setting) ~10 VDC.
- If Ti1 sensor is damaged, fan runs at setting speed.
- When $T_r > T_s + 1^\circ\text{C}$ (Modbus 300033 setting), MTV1 and AUX2 is turned off. DA2 is at 0 VDC. fan is turned on at lowest speed.
- When unit is turned off, MTV1 and AUX2 is turned off. DA2 is at 0 VDC. Fan is turned off delaying 2 minutes.

With Electrical Heater as booster (Modbus300047=1)

When unit is turned on in heating mode.

When $T_r \leq T_s - 1\text{ }^\circ\text{C}$ (Modbus 300033 setting), MTV1 and AUX2 is turned on. Fan is turned on at setting speed. DA2 is at 10 VDC for 2 minutes, then check Ti1:

- If $T_{i1} < 28\text{ }^\circ\text{C}$ (Modbus 300017 setting), EH is turned on. DA2 is at 10 VDC.
- If $28\text{ }^\circ\text{C} < T_{i1} < 28\text{ }^\circ\text{C} + 4\text{ }^\circ\text{C}$ (Modbus 300017 setting), EH is kept at original state. DA2 is at original state.
- If $T_{i1} \geq 28\text{ }^\circ\text{C} + 4\text{ }^\circ\text{C}$ (Modbus 300017 setting), EH is turned off. DA2 output is based on water temperature difference (T_{i1}/T_{i2}) and Modbus parameter 300028 setting PID calculation. The output is minimum output (Modbus300015 setting) ~ 10 VDC.
- If Ti1 sensor is damaged, fan runs at setting speed.
- When $T_r > T_s + 1\text{ }^\circ\text{C}$ (Modbus 300033 setting), MTV1 and AUX2 is turned off. EH is turned off. DA2 is at 0 VDC. fan is turned on at low speed.
- When unit is turned off, MTV1 and AUX2 is turned off. DA2 is at 0 VDC. Fan is turned off delaying 2 minutes.

With Electrical Heater as primary (Modbus300047=2)

When unit is turned on in heating mode.

- When $T_{i2} \leq 35\text{ }^\circ\text{C}$ (or Ti2 is broken) and $T_r \leq T_s - 1\text{ }^\circ\text{C}$ (Modbus 300033 setting), Fan is turned on at setting speed, EH is turned on.
- When $T_r > T_s\text{ }^\circ\text{C}$, EH is turned off. fan is turned on at low speed.
- When unit is turned off, EH is turned off. Fan is turned off delaying 2 minutes.

OVER-HEAT PROTECTION OF INDOOR COIL

- If $T_{i1} \geq 75\text{ }^\circ\text{C}$, then MTV1, AUX2, DA2 and EH are turned off. Indoor fan remains on and runs at high speed.
- If $T_{i1} < 70\text{ }^\circ\text{C}$, then unit keep original state.
- If the indoor coil temperature sensor is damaged or not connected, then the protection mode will be overridden and the unit will work according to the pre-heat and post-heat program.

DEHUMIDIFICATION MODE

When unit is turned on in dehumidification mode:

- AUX1 is turned on. T_s is $24\text{ }^\circ\text{C}$.
- If $T_r \geq 25\text{ }^\circ\text{C}$ for 30S, then MTV1 will be ON for 3 minutes, and then OFF for 4 minutes. DA2 is on at 3 times of (Modbus 300016 setting). Fan is turned on at low speed.
- If $16\text{ }^\circ\text{C} \leq T_r < 25\text{ }^\circ\text{C}$ for 30S, then MTV1 will be ON for 3 minutes, and then OFF for 6 minutes. DA2 is on at double of (Modbus 300016 setting). Fan is turned on at low speed.
- If $T_r < 16\text{ }^\circ\text{C}$ for 30S, then MTV1 will be ON for 3 minutes, and then OFF for 10 minutes. DA2 is on at (Modbus 300016 setting). Fan is turned on at low speed.
- At the end of the above dehumidification cycle, the system will decide the next dehumidification control option.

AUTO MODE

When unit is turned on in Auto mode, fan is turned on at setting speed for 30S, then check T_r and T_s :

- If $T_s \geq T_r + 3\text{ }^\circ\text{C}$, the unit runs in heating mode.
- If $T_r - 3\text{ }^\circ\text{C} < T_s < T_r + 3\text{ }^\circ\text{C}$, the unit runs in fan mode.
- If $T_s < T_r - 3\text{ }^\circ\text{C}$, the unit runs in cooling mode.
- If unit working mode is confirmed, the unit will not change the working mode. After the unit is turned off and restart it in 2 hours, working mode will be confirmed again.

PRO INPUT FUNCTION**When 100004=0**

The unit is on:

- PRO input is closed for 60S, the unit is turned off.
- PRO input is open for 60S, the unit is turned on.

When 100004=1

The unit is on or standby, PRO input is open or closed, the unit is kept original state.

The unit is off,

- PRO input is closed for 30S, MTV1 is turned on, DA2 is open at double of minimum setting (Modbus 300027 setting) and fan is turn on at low speed.
- PRO input is opened for 30S, MTV1 is off, DA2 is 0 VDC, Fan is turn off.
- In period of PRO closed time, if unit receives instruction from remote handset, wired wall pad or Modbus, the unit will work according to the instruction at once.

D.4. Control Logics for 4-Pipe System

Note: 4-pipe system must always be equipped with 2 valves.

COOL MODE

When unit is turned on in cooling mode.

If $T_r \geq T_s + 1^\circ\text{C}$ (Modbus 300033 setting), MTV1 is turned on. AUX1 is closed. Fan is turned on at setting speed. DA2 is turned on at 10 VDC for 2 minutes, then check T_r and T_s .

- DA2 output is from minimum (Modbus 300016 setting) ~ 10 VDC based on T_r and $(T_s + 2)$ PID calculation.
- If $T_r < T_s - 1^\circ\text{C}$ (Modbus 300033 setting), then cool operation is terminated and MTV1 and AUX1 are turned off. Indoor fan runs at set speed. DA2 output is 0 VDC.
- When unit is turned off, MTV1 and AUX1 are off. DA2 is 0 VDC. Fan is turned off delaying 30s.
- The range of T_s is 16 - 30°C
- Indoor fan speed can be adjusted to low, medium, high and auto.

LOW TEMPERATURE PROTECTION OF INDOOR COIL IN COOLING MODE

If $T_{i1} \leq 2^\circ\text{C}$ for 2 minutes

- MTV1 is turned OFF,
- DA2 is set to 0%,
- Indoor fan is turned on to Medium speed if fan runs at low speed.

If $T_{i1} \geq 5^\circ\text{C}$ for 2 minutes

- MTV1 is turned ON,
- DA2 is set to original status,
- Indoor fan is changed to setting speed

FAN MODE

Indoor fan speed can be adjusted for low, medium and high. If fan speed is set auto by Modbus, fan is running at low speed.

HEAT MODE

Without Electrical Heater (Modbus300047=0)

When unit is turned on in heating mode.

When $T_r \leq T_s - 1^\circ\text{C}$ (Modbus 300033 setting), MTV2 and AUX2 is turned on. DA3 is at 10 VDC for 2 minutes, then check T_{i2} :

- If $T_{i2} < 28^\circ\text{C}$ (Modbus 300017 setting), fan is turned on at low speed. DA3 is at 10 VDC.
- If $28^\circ\text{C} < T_{i2} < 28^\circ\text{C} + 4^\circ\text{C}$ (Modbus 300017 setting) $+4^\circ\text{C}$, fan is on at original state. DA3 is at original state.
- If $T_{i2} \geq 28^\circ\text{C} + 4^\circ\text{C}$ (Modbus 300017 setting) $+4^\circ\text{C}$, fan is on at setting speed. DA3 output is from minimum (Modbus 300016 setting) ~ 10 VDC based on T_r and $(T_s - 2)$ PID calculation.
- If T_{i2} sensor is damaged, fan runs at setting speed.
- When $T_r > T_s + 1^\circ\text{C}$ (Modbus 300033 setting) $^\circ\text{C}$, MTV2 and AUX2 is turned off. DA3 is at 0 VDC. fan is turned on at lowest speed.
- When unit is turned off, MTV2 and AUX2 is turned off. DA3 is at 0 VDC. Fan is turned off delaying 2 minutes.

With Electrical Heater as booster (Modbus300047=1)

When unit is turned on in heating mode.

When $T_r \leq T_s - 1^\circ\text{C}$ (Modbus 300033 setting), MTV2 and AUX2 is turned on. Fan is turned on at setting speed. DA3 is at 10 VDC for 2 minutes, then check T_{i2} :

- If $T_{i2} < 28^\circ\text{C}$ (Modbus 300017 setting), EH is turned on. DA3 is at 10 VDC.
- If $28^\circ\text{C} < T_{i2} < 28^\circ\text{C} + 4^\circ\text{C}$ (Modbus 300017 setting) $+4^\circ\text{C}$, EH is kept at original state. DA3 is at original state.
- If $T_{i2} \geq 28^\circ\text{C} + 4^\circ\text{C}$ (Modbus 300017 setting) $+4^\circ\text{C}$, EH is turned off. DA3 output is from minimum (Modbus 300016 setting) ~ 10 VDC based on T_r and $(T_s - 2)$ PID calculation.
- If T_{i2} sensor is damaged, fan runs at setting speed.

- When $T_r > T_s + 1^\circ\text{C}$ (Modbus 300033 setting), MTV2 and AUX2 is turned off. EH is turned off. DA3 is at 0 VDC. fan is turned on at low speed.
- When unit is turned off, MTV2 and AUX2 is turned off. DA3 is at 0 VDC. Fan is turned off delaying 2 minutes.

OVER-HEAT PROTECTION OF INDOOR COIL

- If $T_{i2} \geq 75^\circ\text{C}$, then MTV2, AUX2, DA2 and EH are turned off. Indoor fan remains on and runs at high speed.
- If $T_{i2} < 70^\circ\text{C}$, then unit keep original state.
- If the indoor coil temperature sensor is damaged or not connected, then the protection mode will be overridden and the unit will work according to the pre-heat and post-heat program.

DEHUMIDIFICATION MODE

When unit is turned on in dehumidification mode:

- AUX1 is turned on. T_s is 24°C .
- If $T_r \geq 25^\circ\text{C}$ for 30S, then MTV1 will be ON for 3 minutes, and then OFF for 4 minutes. DA2 is on at 3 times of (Modbus 300016 setting). Fan is turned on at low speed.
- If $16^\circ\text{C} \leq T_r < 25^\circ\text{C}$ for 30S, then MTV1 will be ON for 3 minutes, and then OFF for 6 minutes. DA2 is on at double of (Modbus 300016 setting). Fan is turned on at low speed.
- If $T_r < 16^\circ\text{C}$ for 30S, then MTV1 will be ON for 3 minutes, and then OFF for 10 minutes. DA2 is on at (Modbus 300016 setting). Fan is turned on at low speed.
- At the end of the above dehumidification cycle, the system will decide the next dehumidification control option.

AUTO MODE

When unit is turned on in Auto mode, fan is turned on at setting speed for 30S, then check T_r and T_s :

- If $T_s \geq T_r + 3^\circ\text{C}$, the unit runs in heating mode.
- If $T_r - 3^\circ\text{C} < T_s < T_r + 3^\circ\text{C}$, the unit runs in fan mode.
- If $T_s < T_r - 3^\circ\text{C}$, the unit runs in cooling mode.
- If unit works in heating or fan mode, when $T_r - T_s > 3.0^\circ\text{C}$, MTV2, MTV1 and DA2 is off for more than 10minutes. EH is off for more than 10 minutes, the unit will work in cooling mode.
- If unit works in cooling or fan mode, when $T_s - T_r > 3.0^\circ\text{C}$, MTV2, MTV1 and DA1 is off for more than 10minutes. The unit will work in heating mode.

PRO INPUT FUNCTION

The unit is on:

- PRO input is closed for 60S, the unit is turned off.
- PRO input is open for 60S, the unit is turned on.

D.5. Control logic for 2-pipe with 6-way modulating valve configuration

COOL MODE

1. When unit is turned on in cooling mode.

If $T_r \geq T_s + 1^\circ\text{C}$ (Modbus 300033 setting), MTV1 is turned on. AUX1 is closed. Fan is turned on at setting speed. DA2 is turned on at 0 VDC for 2 minutes, then check Ti1,

- When $T_{i1} \leq 8^\circ\text{C}$, DA2 output is based on water temperature difference (T_{i1}/T_{i2}) and Modbus parameter 300027 setting PID calculation. The output is 4~0 VDC.
- When $8 < T_{i1} \leq 10^\circ\text{C}$, DA2 output is based on water temperature difference (T_{i1}/T_{i2}) and Modbus parameter 300027 setting minus 1 PID calculation. The output is 4~0 VDC.
- When $10 < T_{i1} \leq 12^\circ\text{C}$, DA2 output is based on water temperature difference (T_{i1}/T_{i2}) and Modbus parameter 300027 setting minus 2 PID calculation. The output is 4~0 VDC.
- When $12 < T_{i1} \leq 15^\circ\text{C}$, DA2 output is based on water temperature difference (T_{i1}/T_{i2}) and Modbus parameter 300027 setting minus 3 PID calculation. The output is 4~0 VDC.
- When $15 < T_{i1} \leq 28^\circ\text{C}$ (Modbus 300017 setting), DA2 output is kept at 0 VDC.
- When $T_{i1} > 28^\circ\text{C}$ (Modbus 300017 setting), DA2 output is 4 VDC and report pre-heat alarm.
- If $T_r < T_s - 1^\circ\text{C}$ (Modbus 300033 setting), then cool operation is terminated and MTV1 and AUX1 are turned off. Indoor fan runs at set speed. DA2 output is 5 VDC.
- When unit is turned off, MTV1 and AUX1 are off. DA2 is 5 VDC. Fan is turned off delaying 30s.
- The range of T_s is 16 - 30°C
- Indoor fan speed can be adjusted to low, medium, high and auto.

LOW TEMPERATURE PROTECTION OF INDOOR COIL IN COOLING MODE

If $T_{i1} \leq 2^\circ\text{C}$ for 2 minutes

- MTV1 is turned OFF,
- DA2 is set to 5 VDC,
- Indoor fan is turned on to Medium speed if fan runs at low speed.

If $T_{i1} \geq 5^\circ\text{C}$ for 2 minutes

- MTV1 is turned ON,
- DA2 is set to original status,
- Indoor fan is changed to setting speed

FAN MODE

Indoor fan speed can be adjusted for low, medium and high. If fan speed is set auto by Modbus, fan is running at low speed.

HEAT MODE

Without Electrical Heater (Modbus300047=0)

When unit is turned on in heating mode.

When $T_r \leq T_s - 1^\circ\text{C}$ (Modbus 300033 setting), MTV2 and AUX2 is turned on. DA2 is at 10 VDC for 2 minutes, then check Ti1:

- If $T_{i1} < 28^\circ\text{C}$ (Modbus 300017 setting), fan is turned on at low speed. DA2 is at 10 VDC.
- If $28^\circ\text{C} < T_{i1} < 28^\circ\text{C} + 4^\circ\text{C}$ (Modbus 300017 setting) +4°C, fan is on at original state. DA2 is at original state.
- If $T_{i1} \geq 28^\circ\text{C} + 4^\circ\text{C}$ (Modbus 300017 setting) +4°C, fan is on at setting speed. DA2 output is based on water temperature difference (T_{i1}/T_{i2}) and Modbus parameter 300028 setting PID calculation. The output is 6~10 VDC.
- If Ti1 sensor is damaged, fan runs at setting speed.
- When $T_r > T_s + 1^\circ\text{C}$ (Modbus 300033 setting), MTV1 and AUX2 is turned off. DA3 is at 5 VDC. fan is turned on at lowest speed.
- When unit is turned off, MTV1 and AUX2 is turned off. DA2 is at 5 VDC. Fan is turned off delaying 2 minutes.

With Electrical Heater as booster (Modbus300047=1)

When unit is turned on in heating mode.

When $T_r \leq T_s - 1^\circ\text{C}$ (Modbus 300033 setting), MTV2 and AUX2 is turned on. Fan is turned on at setting speed. DA2 is at 10 VDC for 2 minutes, then check Ti1:

- If $T_{i1} < 28^{\circ}\text{C}$ (Modbus 300017 setting), EH is turned on. DA2 is at 10 VDC.
- If $28^{\circ}\text{C} < T_{i1} < 28$ (Modbus 300017 setting) $+4^{\circ}\text{C}$, EH is kept at original state. DA2 is at original state.
- If $T_{i1} \geq 28$ (Modbus 300017 setting) $+4^{\circ}\text{C}$, EH is turned off. DA2 output is based on water temperature difference (T_{i1}/T_{i2}) and Modbus parameter 300028 setting PID calculation. The output is 6~10 VDC.
- If T_{i1} sensor is damaged, fan runs at setting speed.
- When $T_r > T_s + 1^{\circ}\text{C}$, MTV2 and AUX2 is turned off. EH is turned off. DA2 is at 5 VDC. fan is turned on at low speed.
- When unit is turned off, MTV2 and AUX2 is turned off. DA2 is at 5 VDC. Fan is turned off delaying 2 minutes.

OVER-HEAT PROTECTION OF INDOOR COIL

- If $T_{i1} \geq 75^{\circ}\text{C}$, then MTV1, AUX2, DA2 and EH are turned off. Indoor fan remains on and runs at high speed.
- If $T_{i1} < 70^{\circ}\text{C}$, then unit keep original state.
- If the indoor coil temperature sensor is damaged or not connected, then the protection mode will be overridden and the unit will work according to the pre-heat and post-heat program.

DEHUMIDIFICATION MODE

When unit is turned on in dehumidification mode:

- AUX1 is turned on. T_s is 24°C .
- If $T_r \geq 25^{\circ}\text{C}$ for 30S, then MTV1 will be ON for 3 minutes, and then OFF for 4 minutes. DA2 is 2 VDC. Fan is turned on at low speed.
- If $16^{\circ}\text{C} \leq T_r < 25^{\circ}\text{C}$ for 30S, then MTV1 will be ON for 3 minutes, and then OFF for 6 minutes. DA2 is 2.5 VDC. Fan is turned on at low speed.
- If $T_r < 16^{\circ}\text{C}$ for 30S, then MTV1 will be ON for 3 minutes, and then OFF for 10 minutes. DA2 is 3.5 VDC.
- At the end of the above dehumidification cycle, the system will decide the next dehumidification control option.

AUTO MODE

When unit is turned on in Auto mode, fan is turned on at setting speed for 30S, then check T_r and T_s .

- If $T_s \geq T_r + 3^{\circ}\text{C}$, the unit runs in heating mode.
- If $T_r - 3^{\circ}\text{C} < T_s < T_r + 3^{\circ}\text{C}$, the unit runs in fan mode.
- If $T_s < T_r - 3^{\circ}\text{C}$, the unit runs in cooling mode.
- If unit works in heating or fan mode, when $T_r - T_s > 3.0^{\circ}\text{C}$, MTV2, MTV1 and DA2 is off for more than 10minutes. EH is off for more than 10 minutes, the unit will work in cooling mode.
- If unit works in cooling or fan mode, when $T_s - T_r > 3.0^{\circ}\text{C}$, MTV2, MTV1 and DA2 is off for more than 10minutes. The unit will work in heating mode.

PRO INPUT FUNCTION

The unit is on:

- PRO input is closed for 60S, the unit is turned off.
- PRO input is open for 60S, the unit is turned on.

D.6. Sleep Mode

- SLEEP mode can only be set when the unit is in COOL or HEAT mode.
- In COOL mode, after SLEEP mode is set, the indoor fan will run at auto speed and Ts will increase by 0.5°C each 30 minutes. Maximum setting temperature increased is 3°C.
- In HEAT mode, after SLEEP mode is set, the indoor fan will run at auto speed and Ts will decrease by 0.5 °C each 30 minutes.
- Sleep mode is turned off, Setting temperature go back and Fan is changed to setting speed.

D.7. Buzzer

The unit will beep once when it receives a signal.

D.8. Auto Restart

The system uses non-volatile memory to save the present operation parameters when system is turned off or in case of system failure or cessation of power supply. Operation parameters are mode, set temperature and fan speed. When power supply resumes or the system is switched on again, the same operations as previously set will function.

D.9. On/Off Switch on LED Display Panel

- This is a tactile switch to select Cool→Heat→Off operation mode.
- In COOL mode, the set temperature of the system is 24°C with auto fan speed. There are no timer and sleep modes.
- In HEAT mode, the set temperature of the system is 24°C with auto fan speed. There are no timer and sleep modes.
- Master unit that does not use a wall pad will globally broadcast.

NOTE

When button pressing is effective, master unit buzzer will beep twice and slave unit beeps once.

D.10. Drain Pump (Optional)

Drain pump turns ON if the unit is turned on in cooling or dehumidification mode. It remains on for at least 5 minutes after unit is turned OFF. During mode change from cooling or dehumidification to heating or fan mode, the water pump will turn on for a minimum of 5 minutes.

CAUTION

If the system is turned off at the circuit breaker (or main power supply), the drain pump will not work.

D.11. Float Switch

Float-switch opens before unit is turned on

- If the float switch (N/C) is opened before the unit is turned on, then MTV1 is turned off. The drain pump and indoor fan will operate.
- After float switch is closed, MTV1 is turned on.

Float switch is opened, when unit is turned on

- If the float switch is opened continuously ≥ 5 seconds, then the drain pump will work and MTV1 will remain off.
- After the float switch is closed, the drain pump will run for an additional 5 minutes.
- If the float switch is opened for 10 minutes continuously, then MTV1 will remain off. The indoor fan runs at set speed and the system reports an error.

Float switch is opened, when unit is turned off

- If the float switch is opened, then the drain pump will work.
- After the float switch is closed, the drain pump will run for an additional 5 minutes. If the float switch is opened for 10 minutes continuously, then the system reports an error.

D.12. Electric Heater Safety Switch

- Before the electrical heater is turned on, the EH safety switch must be closed and EC motor RPM must be more than Modbus 310000 setting.
- When electrical heater is ON, electrical heater safety switch is opened for ≥ 1 second or EC motor RPM is lower than Modbus 310000 setting, EH will be turned off immediately and report an error and fan speed is changed to high speed.
- Once the contact is returned to the closed ≥ 180 seconds, reset the error and the heater will start again.
- When EH safety switch is opened ≥ 3 times within 60 minutes, the heater is not allowed to start anymore.
- Turn off the unit to reset the fault, provided that the switch has returned to the closed position.

D.13. Low Temperature Protection of Indoor Coil in Winter

This is frost protection for when the unit is off to prevent water in the coil and room from freezing.

If 2pipe unit is in Standby Mode

If $Tr \leq 2$ °C for 2 minutes

- MTV1 is turned ON,
- AUX2 is closed,
- DA2 is 5 VDC.
- If $Ti1 < 5$ °C for 2 minutes EH (if present) is switched on
- Indoor fan is turned on at low speed.

If $Tr \geq 5$ °C for 2 minutes

- MTV2 is OFF,
- AUX2 is open,
- DA2 is set to 0 VDC.
- Electric Heater is turned Off
- Indoor fan Switched OFF.

If 4-pipe unit is in Standby Mode

If $Tr \leq 2$ °C for 2 minutes

- MTV2 is turned on.
- AUX2 is closed.
- DA3 is 5 VDC. If unit with 6-way valve, DA2 is 8 VDC.
- If $Ti1 < 5$ °C for 2 minutes EH (if present) is switched on.
- Indoor fan is turned on at low speed.

If $Tr \geq 5$ °C for 2 minutes

- MTV2 is off.
- AUX2 is open.
- DA3 is set to 0. If unit with 6-way valve, DA2 is 5 VDC.
- Electric Heater is turned off.
- Indoor fan is switched off.

D.14. Network Setup

- 1) Disconnect the communication plug from the control box



- 2) Communication plug

A, B, A, B is printed on the main PCB. When you connect the wires, please ensure connection of A to A and B to B.

- 3) Connection wire

3.1) If the total length of wire is more than 1000m, please use shielded wire in order to protect the signal transmission.

- 3.2) Complete wire connection

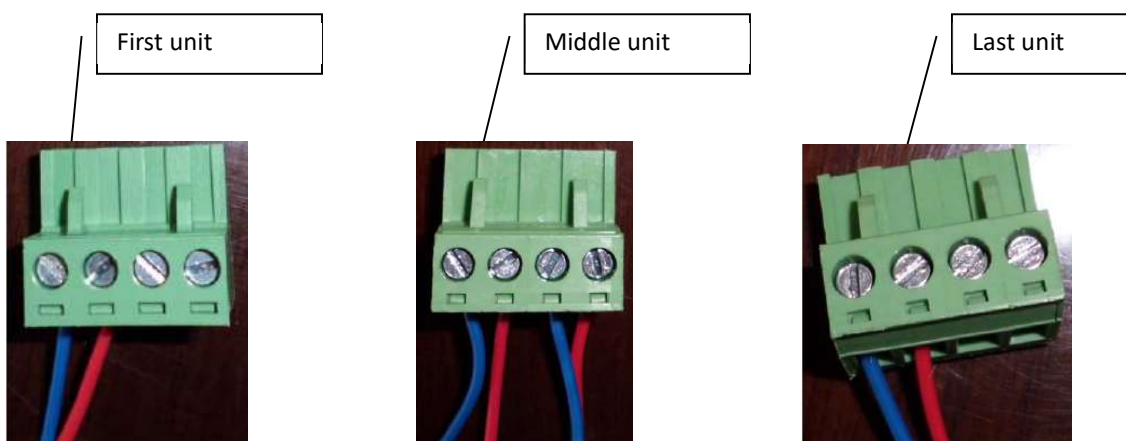
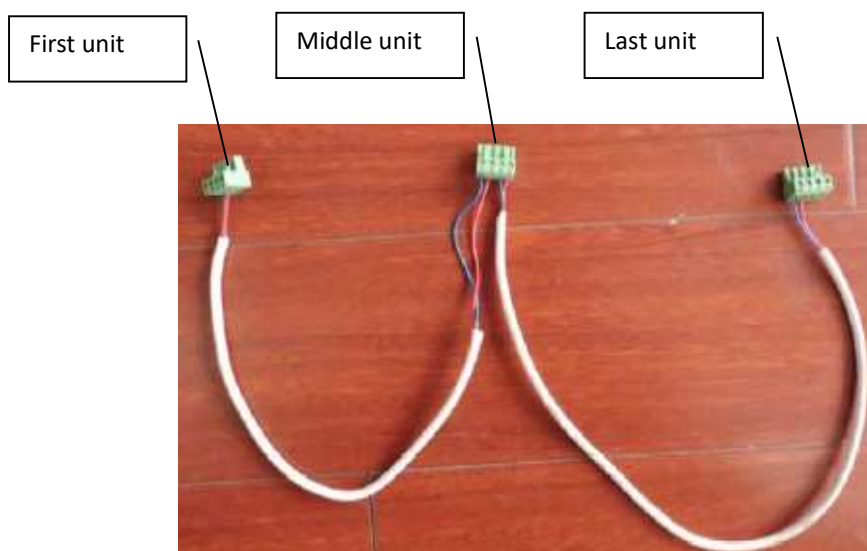

- 3.3) Wire connection check

3.3.1) After the wire connection is completed, please check that the wire colors correspond.

3.3.2) Check the wire contact by using a multimeter.

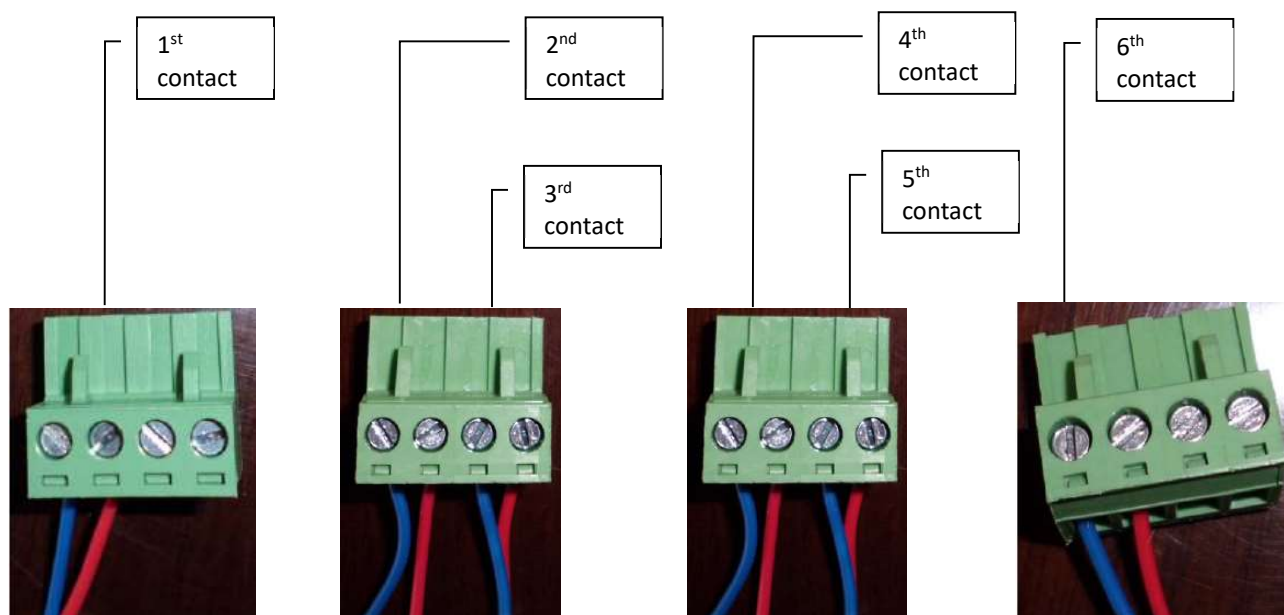

3.3.3) Check 1 and 2, 3 and 4, 5 and 6 to be sure connections are correct.

3.3.4) If the resistance between two wire contacts is too high, please check and reconnect the wire contacts.

- 4) Reconnect the communication plug to control box
- 5) Using wired wall pad or Modbus to set each unit address.

D.15. Open Modbus Protocol

Transfer Mode: RTU BAUD Rate: 9600 bps, 8 data bit, 1 stop bit, none parity bit

The communications require a delay between reading an answer and sending the next command of 80 ms. All temperature is equal to reading data*10 accuracy: 0.1 degree C.

Supported Functions

Function Code	Function description
01(01H)	Read Coils
02(02H)	Read Discrete Inputs
03(03H)	Read Holding Registers
04(04H)	Read Input Registers
05(05H)	Write Single Coil
06(06H)	Write Single Register
15(0FH)	Write Multiple Coils
16(10H)	Write Multiple Registers
255(FFH)	Extended Commands which are used to test.

Valid Error code table:

Error code	description	definition
01 (01H)	Invalid commands	Received commands beyond valid commands
02 (02H)	Invalid data address	Data addresses beyond valid data address
03 (03H)	Invalid data	Data beyond definition range
04 (04H)	Write data not succeed	Write data not succeed

Coils table:

Description	Address	Type*	Remark
ON/OFF	100000	R/W	
Sleeping mode	100001	R/W	
Louver swings	100002	R/W	
Energy Saving Mode	100003	R/W	
PRO function	100004	R/W	

Discrete table:

Description	Address	Type*	Remark
MTV1	200000	R	
MTV2	200001	R	
AUX1	200002	R	
AUX2	200003	R	
Condensate pump	200004	R	
Electrical heater	200005	R	
Wired wall pad	200006	R	
PR-O1	200007	R	
Float switch	200008	R	
Reserved	200009	R	
EH safety switch	200010	R	
Internal test	200011	R	Testing purpose only.

* R = read only, W = write only, R/W = read and write.

Holding Register table:

Description	Address	Type*	Remark
Mode setting	300000	R/W	Cooling mode = 01(H) Humidify mode = 02(H) Fan mode = 04(H) Heating mode = 08(H) Auto mode = 10(H)
Fan speed setting	300001	R/W	Low speed = 04(H) Medium speed = 02(H) High speed = 01(H) Auto fan speed = 07(H)
Louver swing setting	300002	R/W	Position 1=01(H)
			Position2=02(H)
			Position3=03(H)
			Position4=04(H)
			Auto=0F(H)
Stop=00(H)			
Setting temperature	300003	R/W	16~30 (actual*10 format)
Address setting	300004	R/W	1~255
Reset	300005	W	=0x33 reset error
Week	300006	W	
Hour	300007	W	
Minute	300008	W	
Second	300009	W	
Hours in Timer on	300010	R/W	Timer ON
Minute in Timer on	300011	R/W	Timer ON
Hours in Timer off	300012	R/W	Timer OFF
Minute in Timer off	300013	R/W	Timer OFF
Icon of Timer ON or OFF	300014	R/W	BIT0 = Icon of Timer ON BIT1 = Icon of Timer OFF 1 = enable 0 = disable
Minimum output DA1	300015	R/W	Default 25% (2.5 VDC)
Minimum output DA2	300016	R/W	Default 25% (2.5 VDC)
Pre-heat temperature setting	300017	R/W	25~35, default: 30
Reserved-	300018	R/W	
Super low speed rpm	300019	R/W	
Low speed rpm	300020	R/W	
Medium speed rpm	300021	R/W	
High speed rpm	300022	R/W	
Signal output setting	300023	R/W	1~10 VDC (used to test , 0 = disable)
Temperature sampling time	300024	R/W	2~100 , default: 5S
Factor of auto fan speed	300025	R/W	2~150 , default:20
Factor of modulating valve	300026	R/W	2~250 , default:150
Ti1 and Ti2 Cooling difference setting	300027	R/W	3~15 , default:5
Ti1 and Ti2 Heating difference setting	300028	R/W	3~15 default:5
Controller Hardware type setting	300029	R/W	0=air cleaner (S5) 1=FCU (S1/S2/S3, SWC-S) 2=AHU (S6) or (AHU+W5) 3=AHU+AQI (S5+S6) 4=Zone controller(S7) Setting : 1
Degree unit setting	300030	R/W	0=degree C 1=degree F
Temperature display setting	300031	R/W	0=Room temperature display on LED 1=Setting temperature display on LED
Setting temperature range	300032	R/W	0=setting temperature range is from 16~30

			1=Setting temperature range is fixed. Cooling=24oC Heating=21°C
Temperature band setting	300033	R/W	
Reserved	300034	R/W	
Reserved	300035	R/W	
Reserved	300036	R/W	
Reserved	300037	R/W	
Reserved	300038	R/W	
Reserved	300039	R/W	
Reserved	300040	R/W	
Reserved	300041	R/W	
Reserved	300042	R/W	
Reserved	300043	W	
Reserved	300044	W	
Reserved	300045	W	
Software type	300046	R/W	0=2-pipe+MTV. 1=2-pipe without valve 2=4-pipe+std valve 3=4-pipe+6-way valve
EH type	300047	R/W	0=without EH, 1=EH as booster. 2=EH as primary
DA1 control signal	300048	R/W	0=Tr/Ts 1=ESP
EC motor input ports	3000049	R/W	0=CN4 working. 1=CN5 working 2=CN4+CN5 working default : 0
PRO1 input type	300050	R/W	0=NO. 1=NC
Tr sensor setting	300051	R/W	0=sensor on the wired wall pad. 1=sensor on the main PCB. default : 0
Reserved	300052	R/W	0~120 , default : 80
Optimized swing angle	300053	R/W	200~999 default : 0.
E-heater	300054	R/W	Unit : KW*10
Room temp. factor	300055	R/W	90~120 , default : 103
Water inlet temp. factor	300056	R/W	90~120 , default : 103
Delta T factor	300057	R/W	90~120 , default : 102
Product type	300058	R/W	00~99. default : 00
Product model	300059	R/W	000~999. default : 000
Ex-works data	300060	R/W	0000— —9999
Software version	300061	R	10~99 default : 10
Hardware version	300062	R	10~99 default : 10
Reserved	300063	R/W	
Reserved	300064	R/W	
Reserved	300065	R/W	
Reserved	300066	R/W	
Reserved	300067	R/W	
In auto mode, temp. Band setting	300068	R/W	1~15 , default:3
Reserved	300069	R/W	
Reserved	300070	R/W	
Unit power input at High speed	300071	R/W	W*10
Unit power input at Med. speed	300072	R/W	W*10
Unit power input at Low speed	300073	R/W	W*10
Unit heat capacity at High speed	300074	R/W	KW*10
Unit heat capacity at Med. speed	300075	R/W	KW*10
Unit heat capacity at Low speed	300076	R/W	KW*10
Unit cool capacity at High speed	300077	R/W	KW*10
Unit cool capacity at Med. speed	300078	R/W	KW*10
Unit cool capacity at Low speed	300079	R/W	KW*10

* R = read only, W = write only, R/W = read and write.

Input Register table:

Description	Address	Type*	Remark
Tr temperature sensor	400000	R	
Ti1 temperature sensor	400001	R	
Ti2 temperature sensor	400002	R	
Reserved	400003	R	
Reserved	400004	R	
Error code	400005	R	Bit0 = Room temperature sensor error Bit1 = Ti1 temperature sensor error Bit2 = Ti2 temperature sensor error Bit3 = Float switch error Bit4 = Indoor coil low temperature protection Bit5 = Indoor coil over heat protection Bit6 =Filter switch Bit7 = Electrical heater failure Bit8 = Motor1 Error Bit9 =Motor2 Error Bit10 = System parameters error Bit11 = Anti-frozen error Bit12 = Ti3 temperature sensor error Bit13 = Ti4 temperature sensor error Bit14 =PM2.5 sensor Bit15 =AQI Error
Fan speed status	400006	R	Low = 04(H) Medium = 02(H) High = 01(H)
Reserved	400007	R	
Reserved	400008	R	
EH	400009	R	0= disable, 1=booster, 2=primary
Unit type	400010	R	
DA1	400011	R	
DA2	400012	R	
Reserved	400013	R	
Reserved	400014	R	
Reserved	400015	R	
Reserved	400016	R	
Unit status	400017	R	Cooling mode = 01(H) Humidify mode = 02(H) Fan mode = 04(H) Heating mode = 08(H) Unit OFF=32(H)
Temperature in wall pad	400018	R	
Motor running time	400019	R	
Motor running terms	400020	R	0~100
Cooling capacity	400021	R	
Cooling capacity terms	400022	R	0~100
Heating capacity	400023	R	
Heat capacity terms	400024	R	0~100
Reserved	400025	R	
Reserved	400026~35	R	
EC motor1 actual RPM	400036	R	
EC motor2 actual RPM	400037	R	
EC motor1 error	400038	R	
EC motor2 error	400039	R	

D.16. LED Indication and Error Description



Complete Function PCB – I Control Type		
Fan speed setting	LED indication	Condition
High speed	Red LED On	Normal
Medium speed	Yellow LED On	Normal
Low speed	Green LED On	Normal

For all units - Green LED			
Error Description	Blink	Reason	Remedy
Return air sensor failure	Green LED blinks 1 times, stops for 3s	Room sensor unplugged or damaged.	1. Check if Tr plug is connected or not. 2. Check if sensor's resistance is correct or not.
Indoor coil sensor 1 failure	Green LED blinks 2 times, stops for 3s	Ti1 sensor unplugged or damaged.	1. Check if Ti1 plug is connected or not. 2. Check if sensor's resistance is correct or not.
Indoor coil sensor ² failure	Green LED blinks 3 times, stops for 3s	Ti2 sensor unplugged or damaged.	1. Check if Ti2 plug is connected or not. 2. Check if sensor's resistance is correct or not.
Water pump failure	Green LED blinks 4 times, stops for 3s	Float switch is opened.	1. Check if the condensate water pipe is connected or not. 2. Check if the pump is functioning or not.
Indoor coil low temperature protection	Green LED blinks 5 times, stops for 3s	Water temperature is lower than 3 °C.	Check the water temperature.
Indoor coil overheat protection	Green LED blinks 6 times, stops for 3s	Water temperature is higher than 70 °C.	Check the water temperature.
Filter Switch (S6 PCB)	Green LED blinks 7 times, stops for 3s	Filter switch is opened.	1. Check if filter block or not. 2. Replace the new filter.
Electric Heater failure	Green LED blinks 8 times, stops for 3s	Only for unit with EH. EH safety switch is opened.	1. Change fan speed to high. 2. Replace the damaged EH safety switch.
EC motor failure(CN4)	Green LED blinks 9 times, stops 3s	No EC motor feedback	1. Check Modbus setting. 2. Check the EC motor.
EC motor failure(CN5)	Green LED blinks 10 times, stops 3s	No EC motor feedback	1. Check Modbus setting. 2. Check the EC motor.
Anti-frozen protection	Green LED blinks 12 times, stops for 3s	When unit is standby, Tr < 2 °C.	1. Turn on unit to keep Tr high than 5 °C.

E. Control Specifications: Flexible function (W Type)

E.1. Features

- a. Integrated fan relays for zone control applications.
- b. ON/OFF thermostat input and low-voltage modulating fan speed input flexibility.
- c. Simple error diagnostic and LED error display.

E.2. I/O Port Definitions

I/O		Code	2-Pipe	4-Pipe
Analogue input	Coil temperature sensor	AI1	Cooling / heating coil sensor (Ti1)	Cooling only coil sensor (Ti1)
Voltage input	High fan speed	Hi	230VAC input signals from wired thermostat	
	Medium fan speed	M		
	Low fan speed	Lo		
	Phase	L1	External 230VAC power supply connection to the PCB.	
	Neutral	N1, N2		
	Earth	PE		
Signal Input	Modulating signal	AI2, +/-	Low voltage modulating signal input (standard 0~5 VDC, optional 0~10 VDC)	
Digital input	Programming interface	TTL	Low voltage digital signal input for board programming	
	Float switch	FLOAT-A/B	Float Switch connection if equipped	
Voltage output	Water pump	PUMP	Pump connection if equipped	
	EC motor (W3 type)	CN1, CN2	EC motor connection	
Digital output	LED display	X-DIS	IR receiver and alarm display if equipped	
Voltage-free output	Alarm	ALARM	Alarm contact: (a) Standard configuration is (NC) and (NO)	

E.3. Onboard configuration

The PCB can be configured for different modulating signal inputs. Refer to jumper configuration table below.

Code	State	Description
S1	Open	PCB configured for 0~5 VDC modulating signal input.
S1	Closed	PCB configured for 0~10 VDC modulating signal input.
S3	Closed	EC motor output controlled by CN1
S4	Closed	EC motor output controlled by CN2

E.4. Wiring Diagram
Standard EC-W3 Control PCB

EC-W3 Wiring Scheme

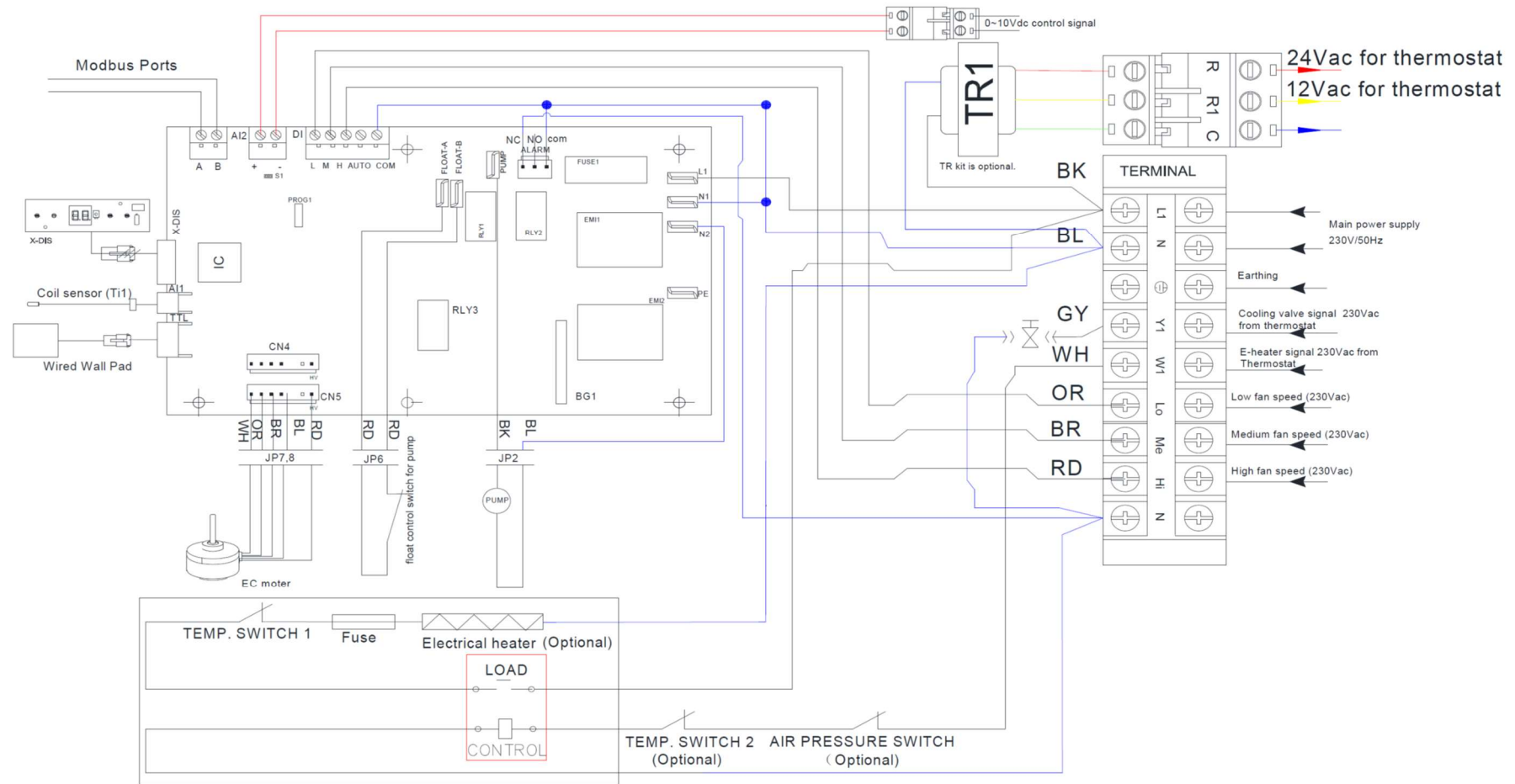

Legend:

AI1: Indoor coil sensor (Ti1)
 AI2: 0~10VDC, EC Motor control signal.
 X-DIS: Led display;
 TTL: Wired wall pad

ALARM: Pump or motor failure, it's opened. V1 and EH stop work.
 PUMP: Water pump output
 CN4, CN5: EC motor output

E.5. Control Logic Specifications

E.5.1. Unit Power ON/OFF

- The unit is turned ON when any of the fan speed inputs (H/M/L) are ON, or modulating signal input is more than 2.0 VDC.
- The unit is turned OFF only if all of the fan speed inputs (H/M/L) are OFF and modulating signal input is less than 2.0 VDC.

E.5.2. Alarm Protection and Error Display

- If the float switch is open for 5 minutes or EC motor is failure, then the (NC) voltage-free alarm contact shall be open and the (NO) voltage free alarm contact shall be closed.
- If the float switch is open for 10 minutes or EC motor is failure, the LED display reports a condensate management failure.

E.5.3. Drain Pump Operation

When the unit turns on:

- If $Ti1 < 14\text{ }^{\circ}\text{C}$, the drain pump turns on.
- If $14\text{ }^{\circ}\text{C} \leq Ti < 16\text{ }^{\circ}\text{C}$, the drain pan keeps original state.
- If $Ti1 \geq 16\text{ }^{\circ}\text{C}$, the drain pump turns OFF.

When the unit turns off, the drain pump will remain ON for 5 minutes and then turn OFF.

At any time:

- If the float switch is OPEN, the drain pump will turn ON.
- If the float switch is OPEN and then CLOSES, the drain pump will remain ON for 5 minutes, and then turn OFF.

E.5.4. Modulating Signal Input

- The standard motor modulating control signal input is 0-10 VDC.

E.5.5. Electrical Heater Operation

- After unit is turned on, EH relay will be ON when EH signal is power on and EC motor RPM>300
- If EC motor failure or EC motor RPM is lower than 300RPM, EH relay is opened at once.

E.5.6. Low Temperature Protection of Indoor Coil in Winter

- This is frost protection when the unit is off to prevent water in the coil from freezing.
- When Unit is in Standby Mode, if $Ti1 \leq 2\text{ }^{\circ}\text{C}$ for 2 minutes, it reports error code and the buzzer beeps.

E.6. LED Display and Error Description

LED receiver in ABS housing with 0.5m (SGS14HFCA-01010101) or 1.8m (SGS14HFCA-01010102) pre-wiring



Flexible Function PCB – W3 Type Control		
Fan speed setting	LED indication	Condition
High speed	Red LED On	Normal
Medium speed	Yellow LED On	Normal
Low speed	Green LED On	Normal

For all units - Green LED blinks			
Item	Blink	Reason	Remedy
Indoor coil sensor 1 failure	Green LED blinks 4 times, stops for 3s	Ti1 sensor connection has problem or is damaged.	<ol style="list-style-type: none"> 1. Check if Ti1 plug is connected or not. 2. Check sensor's resistor.
Water pump failure	Green LED blinks 7 times, stops for 3s	Float switch is opened.	<ol style="list-style-type: none"> 1. Check if the condensate water pipe is connected or not. 2. Check if the pump is functioning or not.
EC motor failure(CN1)	Green LED blinks 9 times, stops 3s	No EC motor feedback.	<ol style="list-style-type: none"> 1. Check S3 setting. 2. Check the EC motor.
EC motor failure(CN2)	Green LED blinks 10 times, stops 3s	No EC motor feedback.	<ol style="list-style-type: none"> 1. Check S4 setting. 2. Check the EC motor.
Anti-frozen protection	Green LED blinks 11 times, stops for 3s	When unit is standby, $Ti1 < 2^{\circ}C$.	<ol style="list-style-type: none"> 1. Turn on unit to keep Ti higher than $5^{\circ}C$.

F. User Interface

F.1. Remote Handset

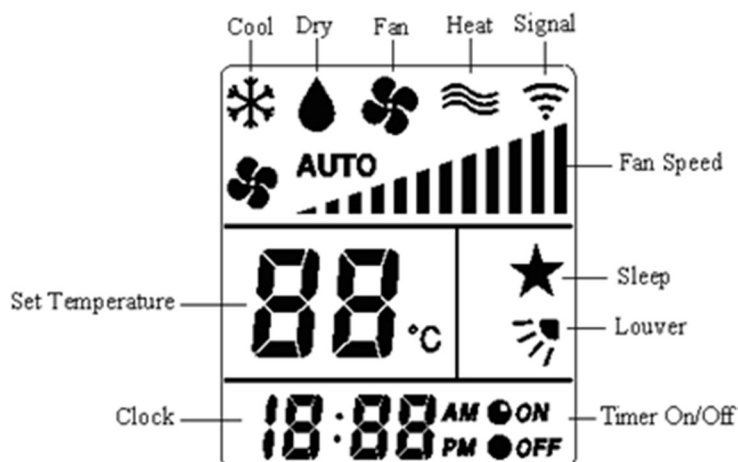
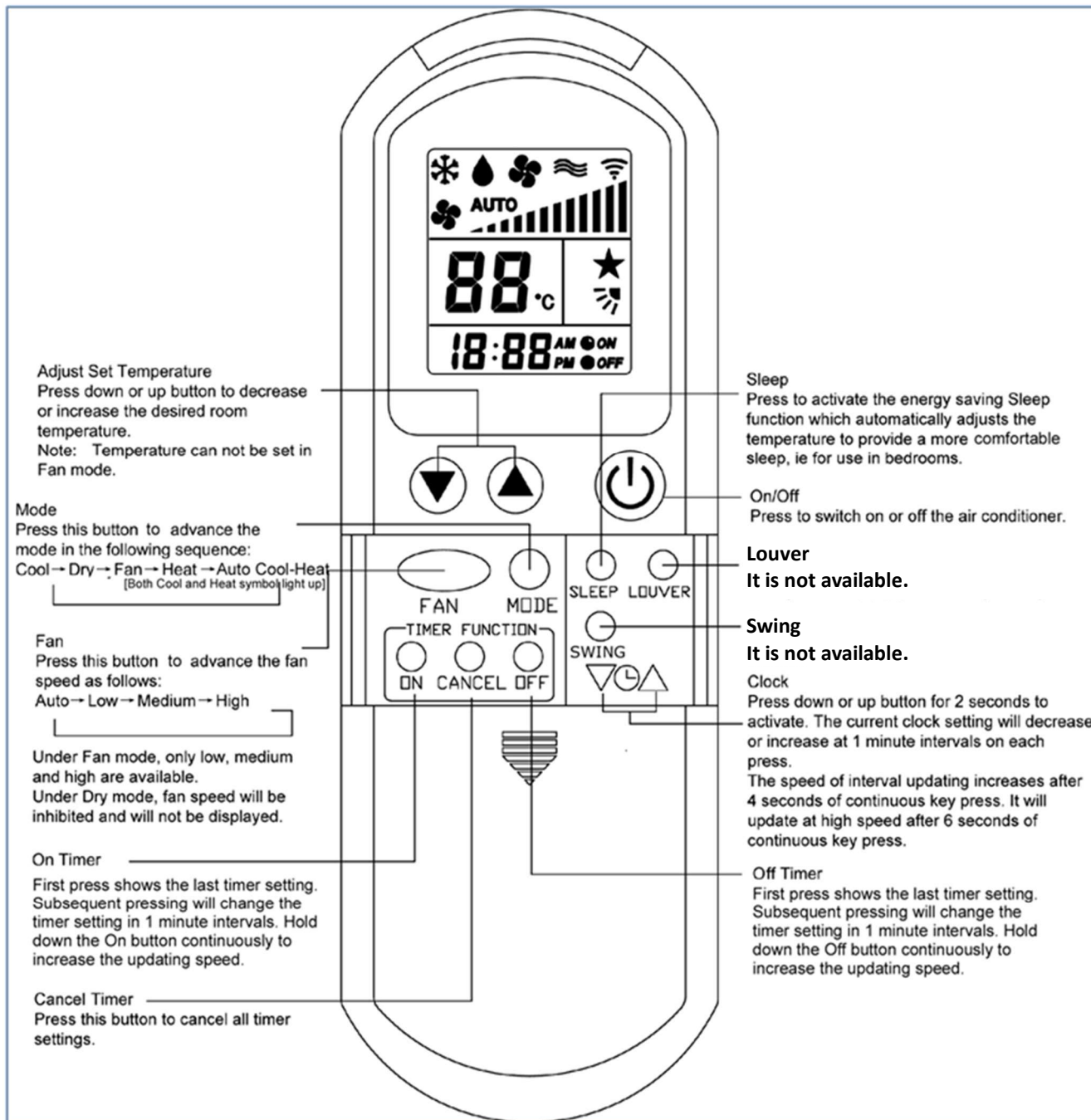

Attention

When unit with handset is the master unit, settings are automatically sent to the slave units. Auto Cool-Heat operation will be applicable in 4-pipe system only.

“Swing” and “Louver” functions are not applicable. European version only uses degree C setting.

F.2. Wired Wall Pad Controller





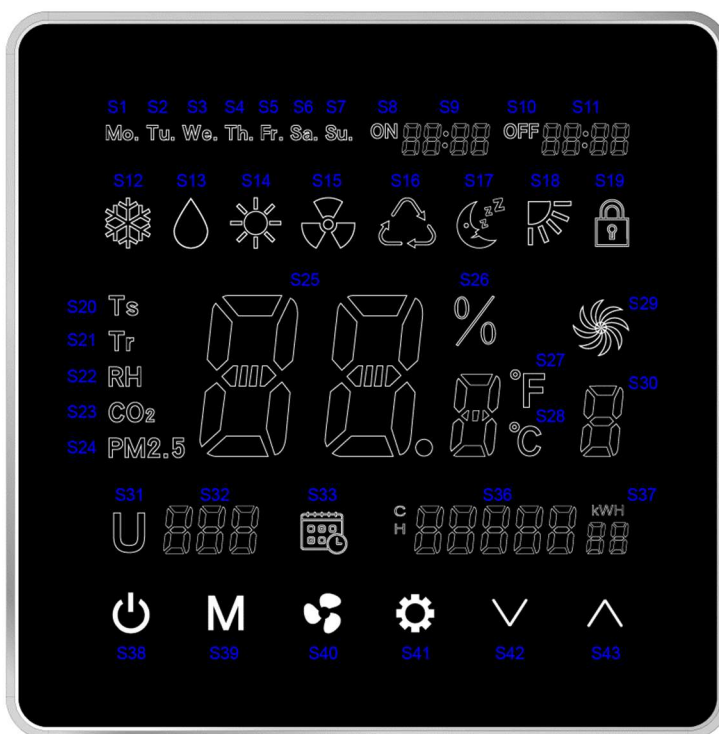























F.2.1. LED display



Code	Legend	Code	Legend	Code	Legend
S1	Monday	S16	Auto Mode	S31	Unit address
S2	Tuesday	S17	Sleep mode	S32	Unit No. / Error code
S3	Wednesday	S18	Swing mode	S33	Weekly timer
S4	Thursday	S19	LED lock	S34	C-cooling
S5	Friday	S20	Setting Temperature	S35	H-heating
S6	Saturday	S21	Room Temperature	S36	Energy consumption
S7	Sunday	S22	RH (if need)	S37	Energy consumption cycle
S8	Timer-ON	S23	CO2 density (if need)	S38	On/Off Button
S9	Timer-ON time (When Timer-ON is off:	S24	PM2.5 density (if need)	S39	Mode setting

	Current time)				
S10	Timer-OFF	S25	Data Display	S38	On/Off Button
S11	Timer-OFF time	S26	RH percentage	S39	Mode setting
S12	Cooling Mode	S27	Fahrenheit degree	S40	Fan speed setting
S13	Dehumidification	S28	Celsius degree	S41	Parameter setting
S14	Heating Mode	S29	Fan	S42	Up
S15	Ventilation Mode	S30	0-Auto. 1-Low. 2-Medium. 3-High	S43	Down

F.2.2. Operation guide

S38	On/OFF Button	Press  to turn on. Press it again to turn off.
S39	Mode button	With wall pad on,  to select Cooling, Dehumidification, Heating, Ventilation or Auto sequentially.
S40	Fan Speed Button	Press  S30 to change from 0 to 3. 0=Auto speed, 1=Low speed, 2=Medium speed, 3=High speed.
S41	Parameter Setting Button	Long press  for 5 seconds to set today's day of week. Press  or  to change from Monday to Sunday.
		Long press  for 5 seconds then short press it once to set current time. Press  or  to change current time.
		Long press  for 5 seconds then short press it twice to set Timer ON. Press  to set day of week from Monday to Sunday. Press  or  to change Timer ON time. Press  to turn Timer ON on or off and S8 appears or disappears.
		Long press  for 5 seconds then short press it 3 times to set Timer OFF time. Press  to set day of week from Monday to Sunday. Press  or  to change Timer OFF time. Press  to turn Timer OFF on or off and S10 appears or disappears.
		Long press  for 5 seconds then short press it 4 times to set group control and U31 appears. The function is reserved.
		Long press  for 5 seconds then short press it 5 times to set unit address and U32 appears. Press  or  to change unit address.
		Long press  for 5 seconds then short press it 6 times to set unit parameters. Press  to change the parameter type. Press  or  to change parameter setting value.

*** For MODBUS user only

S31/S32 displays "U001", which is used to set unit type.
 0=iAIR Mode: Ventilation T, RH, CO2, PM2.5 are displayed.
 1=iFCU Mode: S12, S13, S14, S15, S16, S21 or S20 is displayed.
 2=iAHU Mode: S12, S13, S14, S15, S16, S21 or S20 is displayed.
 3=iAHU with air cleaner Mode: S12, S13, S14, S15, S16, T, RH, CO2, PM2.5 are displayed.

S31/S32 displays "U002", which is used to set unit of temperature degree.
 0=Celsius degree.
 1=Fahrenheit degree.

S31/S32 displays "U003", which is used to select display temperature on LCD.
 1=Setting temperature.
 0=Room temperature.

S31/S32 displays "U004", which is used to set setting temperature range.
 0=Setting temperature is from 16~30°C.
 1=Cooling setting temperature 24°C, Heating setting temperature 21°C.

S31/S32 displays "U005", which is used to set setting temperature band.
 1~9°C.

S31/S32 displays "U006-U009", which are reserved to set parameters with optional accessory to measure PM2.5 and CO2 values.

S31/S32 displays "U010~U011", which are reserved.

S31/S32 displays "U012", which is used to set setting RH point.
 30~70, default: 50

S31/S32 displays "U013", which is used to set setting RH band.
 10~30, default: 10

S31/S32 displays "U014", which is used to set unit address.
 1~255, default: 1

S31/S32 displays "U015", which is used to set unit ESP.
 0~100%, default: 40%

S31/S32 displays "U016", which is reserved.







S31/S32 displays "U017", which is used to set software. (please refer to different PCB)
 0=2-pipe with valve
 1=2-pipe without valve
 2=4-pipe with std valve
 3=4-pipe with 6-way valve

S31/S32 displays "U018", which is reserved.

S31/S32 displays "U019", which is used to set DA1 function
 When U001=2,3
 U019=0, fan control signal is based on Tr, Ts PID calculation
 U019=1, fan control signal is based on ESP PID calculation

S31/S32 displays "U020", which is used to calibrate the sensor on the wired wall pad.
 -5~5, default: -3

S31/S32 displays "U021", which is used to set EH function
 U021= 0, without EH.
 U021= 1, EH as booster.
 U021=2, EH as primary.

		<p>S31/S32 displays “U022”, which is used to select Tr sensor. 0=the sensor in the WWP. 1=the sensor in the PCB.</p> <p>S31/S32 displays “U023”, which is used to display cooling and heating energy consumption. 0=S34/S35/S36/S37 disappears 1=S34/S35/S36/S37 appears In cooling and dehumidification mode, cooling energy consumption is shown. In heating mode, heating energy consumption is shown. 2=Motor running time is shown.</p> <p>S31/S32 displays “U024”, which is used to set low speed RPM or control signal.</p> <p>S31/S32 displays “U025”, which is used to set medium speed RPM or control signal.</p> <p>S31/S32 displays “U026”, which is used to set high speed RPM or control signal.</p> <p>S31/S32 displays “U027”, which is used to set Delta T OF Ti1/Ti2.</p> <p>S31/S32 displays “U028”, which is used to set Delta T OF Ti3/Ti4.</p> <p>S31/S32 displays “U029”, which is used to read unit type.</p> <p>S31/S32 displays “U030”, which is used to read unit model.</p> <p>S31/S32 displays “U031”, which is used to read unit manufacturing date.</p>
S32	Error code	<p>S32 : E** blinks</p> <p>Bit0 = Room temperature sensor error Bit1 = Ti1 temperature sensor error Bit2 = Ti2 temperature sensor error Bit3 = Float switch error Bit4 = Indoor coil low temperature protection Bit5 = Indoor coil overheat protection Bit6 =Filter switch Bit7 = Electrical heater failure Bit8 = Motor1 Error Bit9 =Motor2 Error Bit10 = System parameters error Bit11 = Anti-frozen error Bit12 = Ti3 temperature sensor error Bit13 = Ti4 temperature sensor error Bit14 =PM2.5 sensor error Bit15 =AQI Error</p>
Combination Button Function		<p>Screen Lock Function</p> <p>Long press  for 5 seconds, S19 appears and screen is locked.</p> <p>Long press  for 5 seconds again, S19 disappears and screen is unlocked.</p> <hr/> <p>Swings Function</p> <p>Long press  for 5 seconds, S18 appears and swings is ON.</p> <p>Long press  for 5 seconds again, S18 disappears and swings is OFF.</p> <hr/> <p>Sleep Mode</p> <p>Long press  for 5 seconds, S17 appears and sleep mode is ON.</p> <p>Long press  for 5 seconds again, S17 disappears and sleep mode is OFF.</p>

F.2.3. Error Code List

Error Description	Code	Reason	Remedy
Room temperature sensor error	E1	Room sensor unplugged or damaged.	1. Check if Tr plug is connected or not.
			2. Check if sensor's resistance is correct or not.
Indoor coil sensor 1 failure	E2	Ti1 sensor unplugged or damaged.	1. Check if Ti1 plug is connected or not.
			2. Check if sensor's resistance is correct or not.
Indoor coil sensor 2 failure	E3	Ti2 sensor unplugged or damaged.	1. Check if Ti2 plug is connected or not.
			2. Check if sensor's resistance is correct or not.
Float switch error	E4	Float switch is opened.	1. Check if the condensate water pipe is connected or not.
			2. Check if the pump is functioning or not.
Indoor coil low temperature protection	E5	Water temperature is lower than 3 °C.	Check the water temperature.
Indoor coil overheat protection	E6	Water temperature is higher than 70 °C.	Check the water temperature
Filter switch protection	E7	Filter Switch is open.	Replace or clean filter.
Electric Heater failure	E8	Only for unit with EH.	1. Change fan speed to high.
		EH safety switch is opened.	2. Replace the damaged EH safety switch.
EC motor failure(CN4)	E9	No EC motor feedback	1. Check Modbus setting.
			2. Check the EC motor.
EC motor failure(CN5)	E10 E11	No EC motor feedback	1. Check Modbus setting.
			2. Check the EC motor.
Motor qty setting error (S6 PCB)	E12	Motor Qty setting error	1: check Modbus setting
Anti-frozen protection		When unit is standby, Tr<2°C.	1. Turn on unit to keep Tr high than 5°C
Indoor coil sensor 3 failure (S6 PCB)	E13	Ti3 sensor unplugged or damaged.	1. Check if Ti3 plug is connected or not.
			2. Check if sensor's resistance is correct or not.
Indoor coil sensor 4 failure (S6 PCB)	E14	Ti4 sensor unplugged or damaged.	1. Check if Ti4 plug is connected or not.
			2. Check if sensor's resistance is correct or not.
PM2.5 sensor failure (S6 PCB)	E15	PM2.5 sensor unplugged or damaged.	1. Check if PM2.5 plug is connected or not.
			2. Check if sensor's resistance is correct or not.
AQI sensor failure (S6 PCB)	E16	AQI sensor unplugged or damaged.	1. Check if AQI plug is connected or not.
			2. Check if sensor's resistance is correct or not.
Wired Wall Pad failure	E17	WWP unplugged or not well	1. Check plugs

F.2.4. Dimensions and installation

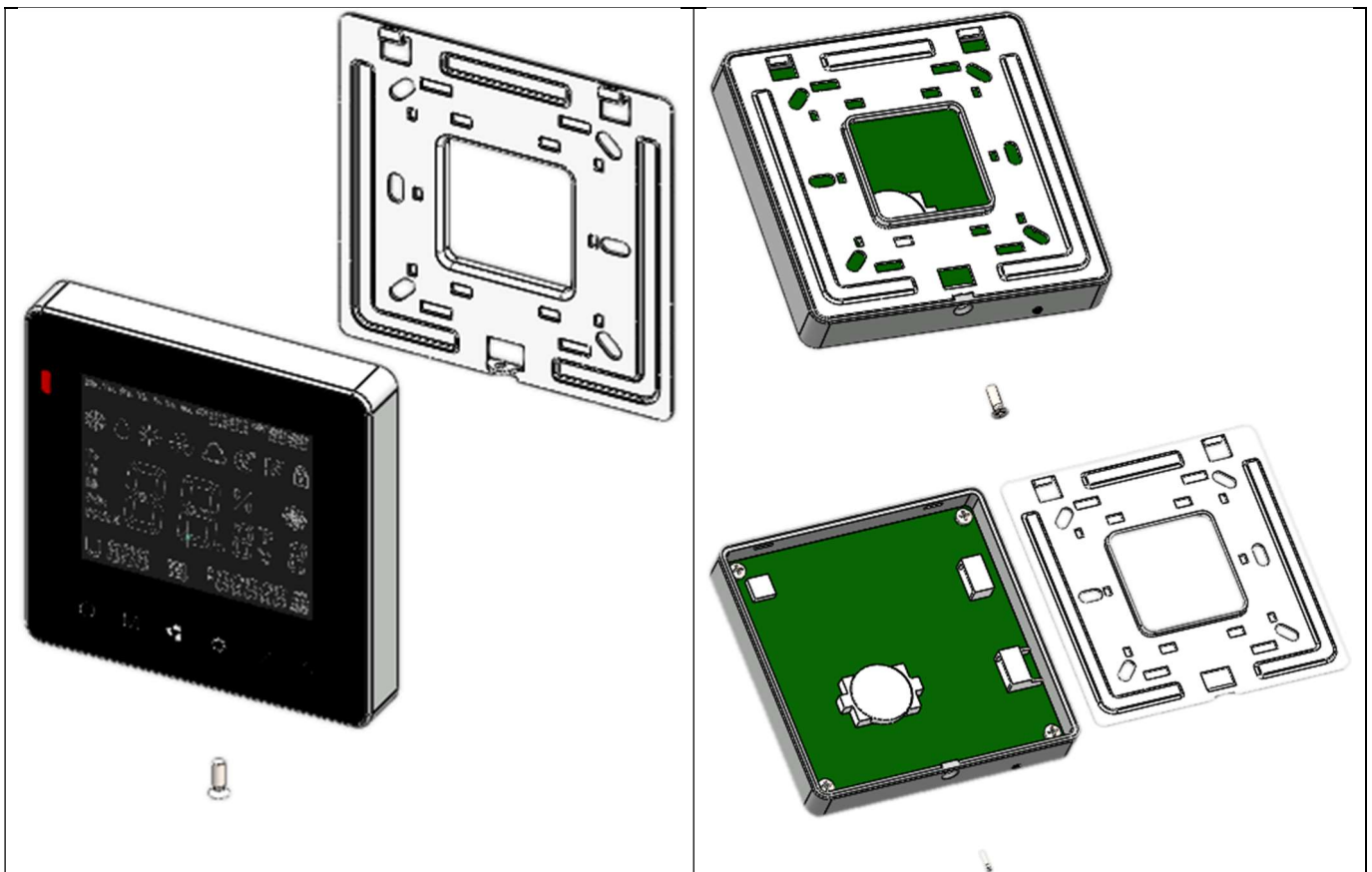
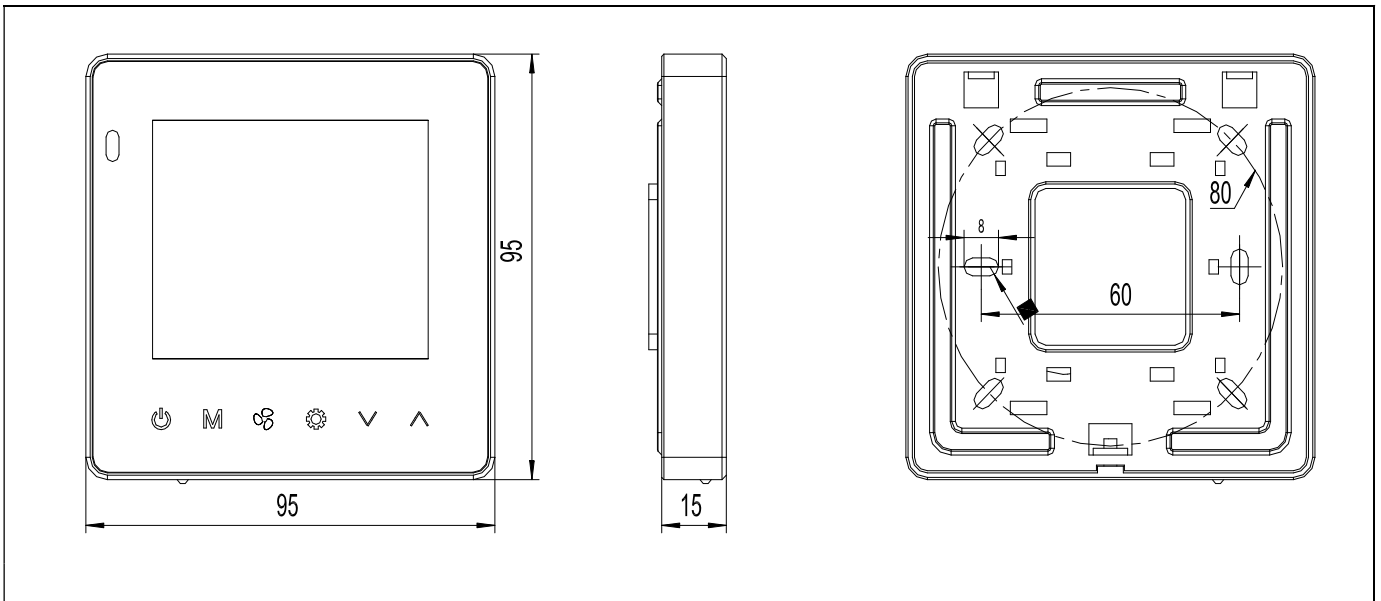

Use screwdriver to remove the screw on the bottom

G. Sensor Resistance R-T Conversion Table

Resistance: $R(25^{\circ}\text{C}) = 10\text{K}\Omega \pm 1\%$ Beta Constant: $B(25/85) = 3950 \pm 1\%$

Temp. (deg. C)	Rmax (k Ohms)	Rnor (k Ohms)	Rmin (k Ohms)	Temp. (deg. C)	Rmax (k Ohms)	Rnor (k Ohms)	Rmin (k Ohms)
-30	186.3613	179.2666	172.4247	5	25.9521	25.4562	24.9672
-29	174.9608	168.4053	162.0793	6	24.6872	24.2274	23.7738
-28	164.3317	158.2726	152.4218	7	23.4912	23.0650	22.6443
-27	154.4170	148.8151	143.4022	8	22.3599	21.9650	21.5750
-26	145.1643	139.9837	134.9746	9	21.2897	20.9239	20.5622
-25	136.5254	131.7332	127.0964	10	20.2768	19.9380	19.6028
-24	128.4558	124.0216	119.7285	11	19.3178	19.0041	18.6937
-23	120.9146	116.8107	112.8348	12	18.4096	18.1193	17.8318
-22	113.8640	110.0648	106.3818	13	17.5493	17.2807	17.0146
-21	107.2691	103.7512	100.3387	14	16.7340	16.4857	16.2394
-20	101.0977	97.8396	94.6771	15	15.9612	15.7317	15.5040
-19	95.3201	92.3020	89.3705	16	15.2284	15.0164	14.8059
-18	89.9088	87.1124	84.3946	17	14.5333	14.3376	14.1432
-17	84.8385	82.2471	79.7268	18	13.8738	13.6933	13.5139
-16	80.0856	77.6837	75.3463	19	13.2479	13.0816	12.9160
-15	75.6284	73.4018	71.2336	20	12.6537	12.5005	12.3479
-14	71.4468	69.3823	67.3708	21	12.0895	11.9485	11.8080
-13	67.5220	65.6077	63.7412	22	11.5535	11.4239	11.2946
-12	63.8370	62.0616	60.3295	23	11.0442	10.9252	10.8064
-11	60.3755	58.7288	57.1212	24	10.5602	10.4510	10.3419
-10	57.1228	55.5953	54.1032	25	10.1000	10.0000	9.9000
-9	54.0651	52.6480	51.2629	26	9.6709	9.5709	9.4710
-8	51.1895	49.8747	48.5889	27	9.2623	9.1626	9.0630
-7	48.4842	47.2643	46.0705	28	8.8732	8.7738	8.6747
-6	45.9381	44.8062	43.6978	29	8.5025	8.4037	8.3052
-5	43.5409	42.4906	41.4615	30	8.1494	8.0512	7.9534
-4	41.2831	40.3086	39.3531	31	7.8128	7.7154	7.6184
-3	39.1559	38.2516	37.3644	32	7.4919	7.3953	7.2993
-2	37.1508	36.3117	35.4880	33	7.1859	7.0903	6.9953
-1	35.2603	34.4817	33.7169	34	6.8940	6.7995	6.7056
0	33.4771	32.7547	32.0447	35	6.6156	6.5221	6.4294
1	31.7945	31.1243	30.4652	36	6.3498	6.2576	6.1660
2	30.2064	29.5847	28.9728	37	6.0962	6.0051	5.9148
3	28.7068	28.1301	27.5623	38	5.8540	5.7642	5.6752
4	27.2904	26.7556	26.2286	39	5.6227	5.5342	5.4465

Temp. (deg. C)	Rmax (k Ohms)	Rnor (k Ohms)	Rmin (k Ohms)	Temp. (deg. C)	Rmax (k Ohms)	Rnor (k Ohms)	Rmin (k Ohms)
40	5.4018	5.3146	5.2283	77	1.4137	1.3722	1.3317
41	5.1907	5.1049	5.0199	78	1.3681	1.3275	1.2880
42	4.9890	4.9045	4.8210	79	1.3243	1.2845	1.2458
43	4.7961	4.7130	4.6309	80	1.2820	1.2431	1.2053
44	4.6117	4.5300	4.4494	81	1.2413	1.2033	1.1663
45	4.4354	4.3551	4.2759	82	1.2021	1.1649	1.1287
46	4.2667	4.1878	4.1100	83	1.1644	1.1279	1.0926
47	4.1053	4.0278	3.9515	84	1.1279	1.0923	1.0577
48	3.9508	3.8748	3.7999	85	1.0928	1.0580	1.0241
49	3.8030	3.7283	3.6548	86	1.0590	1.0249	0.9918
50	3.6614	3.5882	3.5161	87	1.0264	0.9930	0.9606
51	3.5258	3.4540	3.3833	88	0.9949	0.9623	0.9306
52	3.3960	3.3255	3.2562	89	0.9646	0.9326	0.9016
53	3.2715	3.2025	3.1346	90	0.9353	0.9040	0.8737
54	3.1523	3.0846	3.0181	91	0.9070	0.8764	0.8468
55	3.0380	2.9717	2.9065	92	0.8797	0.8498	0.8208
56	2.9285	2.8635	2.7996	93	0.8534	0.8241	0.7958
57	2.8234	2.7597	2.6972	94	0.8280	0.7994	0.7716
58	2.7227	2.6603	2.5990	95	0.8035	0.7754	0.7483
59	2.6260	2.5649	2.5049	96	0.7798	0.7523	0.7258
60	2.5333	2.4734	2.4147	97	0.7569	0.7300	0.7041
61	2.4443	2.3856	2.3282	98	0.7348	0.7085	0.6831
62	2.3589	2.3014	2.2452	99	0.7134	0.6877	0.6628
63	2.2768	2.2206	2.1656	100	0.6928	0.6676	0.6433
64	2.1981	2.1431	2.0892	101	0.6728	0.6482	0.6244
65	2.1224	2.0686	2.0159	102	0.6536	0.6295	0.6062
66	2.0498	1.9970	1.9455	103	0.6349	0.6113	0.5885
67	1.9800	1.9283	1.8779	104	0.6169	0.5938	0.5715
68	1.9129	1.8623	1.8130	105	0.5995	0.5769	0.5550
69	1.8484	1.7989	1.7507	106	0.5826	0.5605	0.5391
70	1.7864	1.7380	1.6908	107	0.5663	0.5447	0.5237
71	1.7267	1.6794	1.6332	108	0.5506	0.5293	0.5089
72	1.6694	1.6231	1.5779	109	0.5353	0.5145	0.4945
73	1.6142	1.5689	1.5247	110	0.5206	0.5002	0.4806
74	1.5612	1.5168	1.4736	111	0.5063	0.4863	0.4671
75	1.5101	1.4667	1.4245	112	0.4924	0.4729	0.4541
76	1.4610	1.4185	1.3772	113	0.4791	0.4599	0.4415

H. Troubleshooting

Symptoms	Cause	Remedy
The fan coil does not start up	No voltage	Check for presence of voltage Check fuse on board
	Mains switch in the "OFF" position	Place in the "ON" position
	Faulty room control	Check the room control
	Faulty fan	Check fan motor
Insufficient output	Filter clogged	Clean the filter
	Air flow obstructed	Remove obstacles
	Room control regulation	Check the room air sensor
	Incorrect water temperature	Check the water source
	Air present	Check the air vent
Noise and vibrations	Contact between metal parts	Check for loosening parts
	Loose screws	Tighten screws



Note: All the information or data in this manual may be changed without notice.

EUROPE

C / Rio Jucar, Nave 6 P.I El Saladar
Lorquí; Murcia, Spain 30564
Ph: (+34) 968 046 262

ASIA

6 On Ping St, R.6 - Block A, 9th Floor,
New Trade Plaza, Shatin, Hong Kong
Ph: (+852) 2648 8887

www.pghvac.com

contact@pghvac.com