

# FAN COIL

IMPERIAL TECHNICAL  
CATALOG 2024



**POLARAIR**



**POLARAIR**

The logo for Polar Air features the word "POLARAIR" in a bold, blue, sans-serif font. The letters "AIR" are white and are contained within a blue speech bubble shape that has a small tail pointing downwards and to the right.

<b>OUR COMPANY</b>	3
<b>WHY POLAR AIR</b>	4
<b>PRODUCT OVERVIEW</b>	8
<b>CONTROL OPTIONS</b>	10
<b>OUR SERVICES</b>	12
<b>OUR SELECTION SOFTWARE</b>	13
<b>OUR FAN COILS</b>	14
<b>Highwall</b>	
PHW - Highwall fan coil	16
<b>Cassettes</b>	
PCGH-3R - 4 Way Cassette	22
<b>Ducted</b>	
PDWSL - Slim ESP Ducted	28
• PDWA - Medium ESP Ducted	34
• PDWC - High ESP Ducted	44
<b>Specialty Application Ducted</b>	
• PDWD - Double Skin High ESP Ducted	52
• HAHU - Horizontal Mini Air Handling Unit	60
• VAHU - Vertical Mini Air Handling Unit	68
<b>Console</b>	
• PFWBC - Standard Console	74
• PFWSL - Slim Console	80
<b>OUR ACCESSORIES</b>	86

Since 1998, Polar Air has been dedicated to developing and delivering **customer-oriented, effective, and sustainable indoor climate solutions** worldwide. With three strategically located offices in **Boston, Murcia, and Hong Kong**, we have a global reach to serve your needs.

As part of the Polar Global group, Polar Air aligns with Polar Global's **vision of making every indoor space ideal for the well-being of all, while contributing to environmental sustainability**. Our mission prioritizes energy savings and environmental responsibility, utilizing innovative and intelligent approaches to help our clients achieve the perfect indoor climate.

At Polar Air, we've cultivated vital partnerships and personal connections worldwide, providing us with specialized insights and market knowledge. This knowledge drives constant improvements in our product designs, manufacturing processes, and quality assurance procedures, ensuring that our solutions evolve with the market.

Our multicultural team of professionals is dedicated to delivering not only effective but also efficient, intelligent, and environmentally responsible products. **We're proud to be part of the Polar Global group, sharing its values of integrity, innovation, sustainability, and an unwavering focus on our customers.**

**Committed to a sustainable future**, we aim to reduce energy consumption and carbon emissions through our innovative and intelligent indoor climate solutions. Our most valuable resource is our people, including Polar Air team members and our industry partners, working together to deliver top-quality, sustainable indoor climate solutions tailored to your unique requirements from our vast selection of over 1800 configurations.



**+25**  
YEARS  
EXPERIENCE

**100%**  
CUSTOMER-ORIENTED  
APPROACH

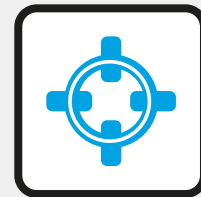

**+27**  
COUNTRIES  
WORLDWIDE

**+1800**  
PRODUCT  
CONFIGURATIONS

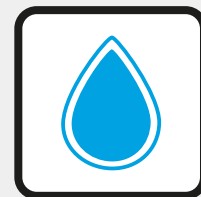

## **IT'S NOT JUST ABOUT HVAC; IT'S ABOUT THE ULTIMATE INDOOR CLIMATE EXPERIENCE.**

We redefine the HVAC experience by combining innovation, sustainability, and unparalleled customer service.

We are more than just an HVAC provider; we are your trusted partner in delivering the ultimate indoor climate experience. When you choose Polar Air, you choose an extraordinary customer experience. We offer services that are second to none, a team of dedicated professionals, unwavering professionalism, personalized attention, and an irresistible product offering.



### **ENERGY EFFICIENCY**

We're obsessed with efficiency. Our wide product range enables precise load match efficiency. Our Delta T management ensures optimized water flow, leading to enhanced efficiency and reduced energy costs.

### **TOP-LEVEL CUSTOMER SERVICE**

We're not just here to sell; we're here to support you. Our top-level customer service extends beyond the sale, offering technical training and access to the power of PG Modbus, ensuring you are empowered to make informed decisions.

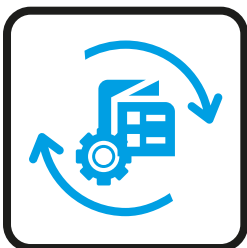

### **COMPREHENSIVE PRODUCT RANGE**

Our product portfolio is a testament to our dedication to meeting every HVAC need. From our diverse product offerings to the myriad options and accessories available, we ensure your unique requirements are met with precision.

## WATER-BASED HVAC SYSTEMS

At Polar Air, we specialize in water-based HVAC systems, seamlessly integrating this renewable source to drive efficient climate control while reducing environmental impact.

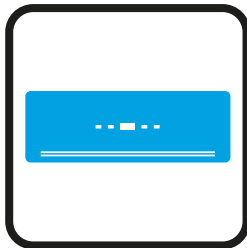
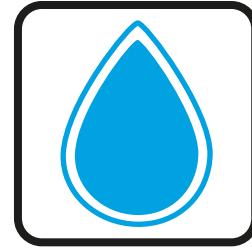

## AESTHETIC EXCELLENCE

We understand the importance of aesthetics in your space. Our products boast a modern, plastic design that seamlessly integrates with your environment, ensuring that form complements function.

## USER-FRIENDLY CONTROLS

Say goodbye to expensive in-field installations and programming. Our onboard controls eliminate the need for complex setups, ensuring ease of use and substantial cost savings.

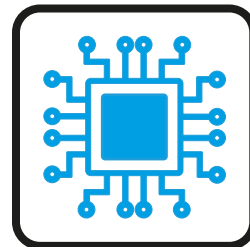

As you browse through the catalog, you will see that every product is a testament to our dedication to innovation, customer satisfaction, and environmental responsibility. At Polar Air, we believe that everyone deserves to experience elevated comfort while contributing to a sustainable world.

Thank you for considering Polar Air, and we look forward to partnering with you to create a world of exceptional comfort and sustainability.

Polar Air has the widest range of fan coils in the world, adapted to each specific market requirement with a wide variety of accessories and options.

Our extensive range includes over 1800 models/sizes of EC motor hydronic fan coils, all adhering to AHRI performance and Eurovent performance and sound standards. Our products are approved with CE and ETL certifications.

To simplify the selection of the best fit for your projects, we've created a comprehensive table that provides a clear overview of the cooling and heating capacities (in MBH) across our entire product range.

We understand that projects often call for special solutions, and we strive to offer maximum flexibility to customize products based on unique project requirements.

### Total Capacity (MBH)

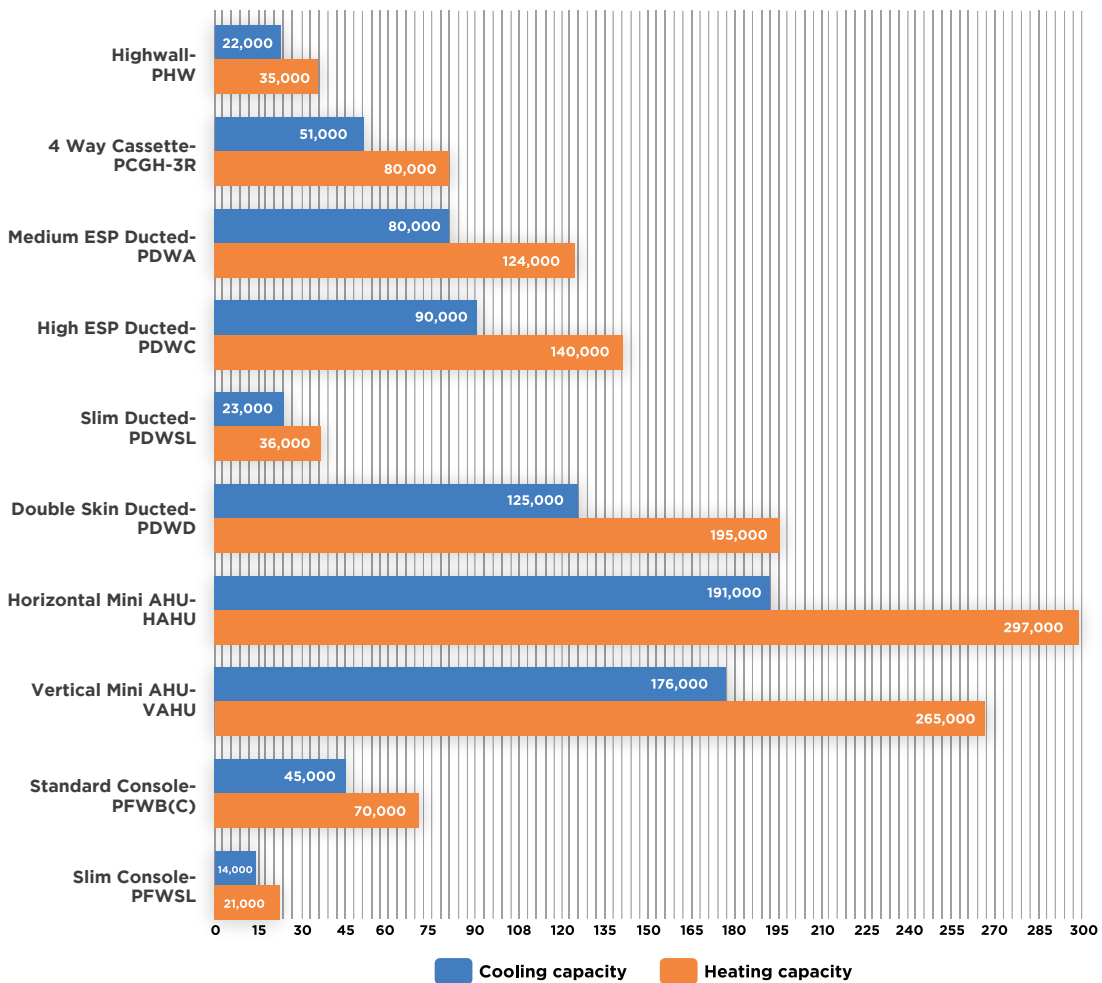



## WHICH DUCTED SHOULD I CHOOSE?

These tables assist customers in finding the most suitable model for their needs, providing indicative performance values under AHRI standard conditions. For a more detailed view, refer to the specifications tables or utilize our Selection Software for customized project conditions.

Ducted units are commonly selected based on Airflow or Cooling Capacity with consideration for external static pressure (ESP). The first table compares Cooling Capacity based on ESP, while the second table compares airflow based on ESP. These tables guide users in choosing the appropriate ducted unit type (PDWC, PDWA, HAHU, etc.). However, for precise unit size and configuration details, use one of the methods mentioned above.

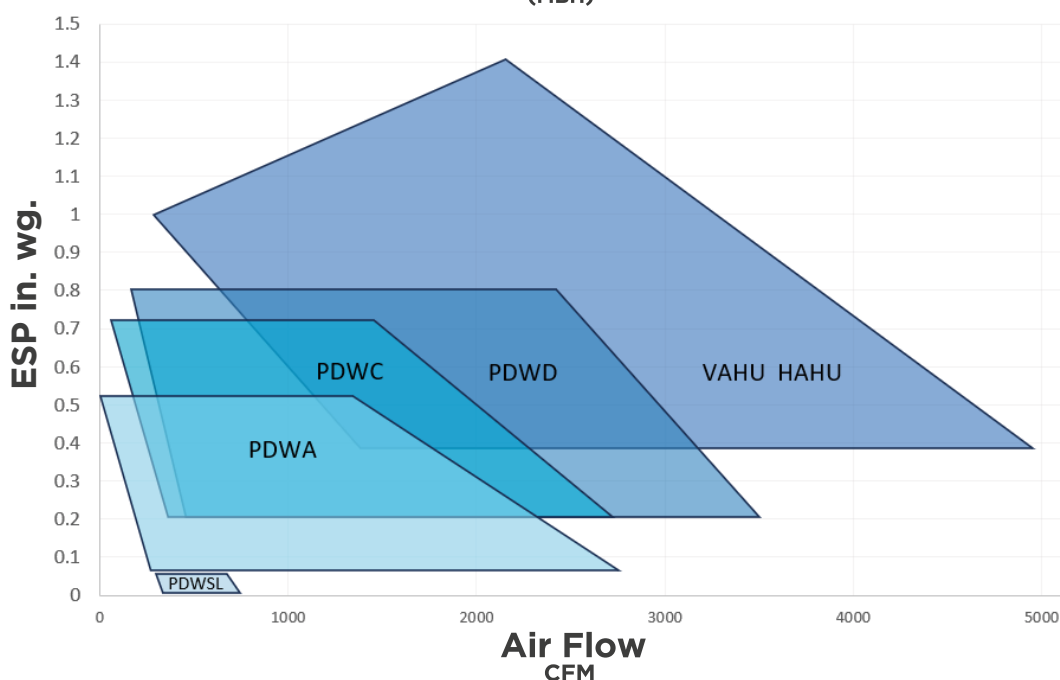
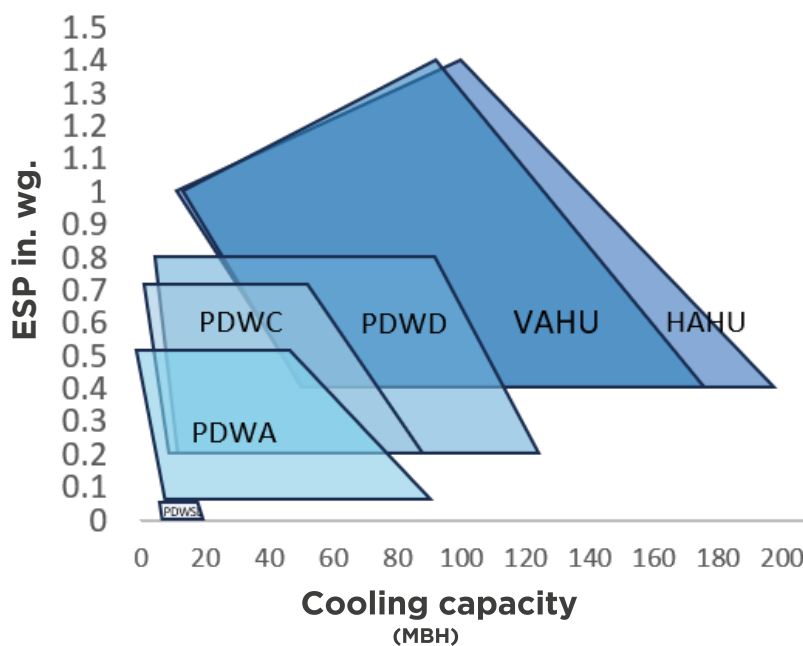

\*High fan considered for making the graphs.

\*Tested at AHRI conditions

All Polar Air fan coil units offer maximum levels of control flexibility, by selecting from two types of controllers depending on application needs.

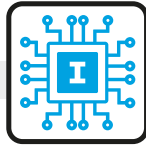

### [I-CONTROL]

CONTROLLED WITH BMS OR POLAR AIR WALL PAD AND IR HANDSET



### [W-CONTROL]

CONTROLLED WITH EXTERNAL THERMOSTAT APPLICATIONS OR EXTERNAL CONTROLLER



# CONTROL OPTIONS

## [I-CONTROL] PCB WITH INTELLIGENT FUNCTIONALITY

The PCB microprocessor intelligent control board controls the operation of the indoor fan motor, ON/OFF or modulating water valves, and electric heaters (if fitted) to maintain room conditions at a user-defined set point.

- Full control logic connectivity via Modbus RTU or using a gateway with other communication protocols.
- Auto Fan Speed control for EC.
- Modulating Valve Control to adjust the water flow 100% according to the room temperature and set temperature.
- Auto Restart function.
- Drain Pump control (If installed)
- Autodynamic balancing function for Variable Water Flow system installations.

## [W-CONTROL] FLEXIBLE CONTROL PCB

This control option features flexible functionality for external thermostat applications, allowing the independent control of drain pumps and limited LED diagnostics.

- Independent control of drain pumps (if installed)
- Zone control operations
- Limited LED Diagnostics
- Louver control (when applicable).

## WHAT DO WE CALL INTELLIGENT FUNCTIONALITY? EXPLAINING THE AUTODYNAMIC BALANCING FUNCTION

The I-Control, also known as the Intelligent control, goes a step further than your typical control PCB.

There is a certain calculated load for every space that a fan coil will serve, but this of course, is not constant. Occupancy, lighting, even an open window, can affect the required load for a space. The typical solution for this is a PICV (pressure independent control valve), but that comes at quite a cost premium.

With our Intelligent control, we do away with the PICV and simply install temperature sensors within the water inlet and outlet, air inlet, and in the space from our own Wired Wall Pad, to monitor those points.

With that data, the “intelligence” of the unit is able to modulate the valve and fan speed to maintain the delta T setpoint this is what we call “Auto Dynamic Balancing” providing optimal cooling to the space at all times. All of this coming in one package at a much lower cost than going with a 3rd party PICV.

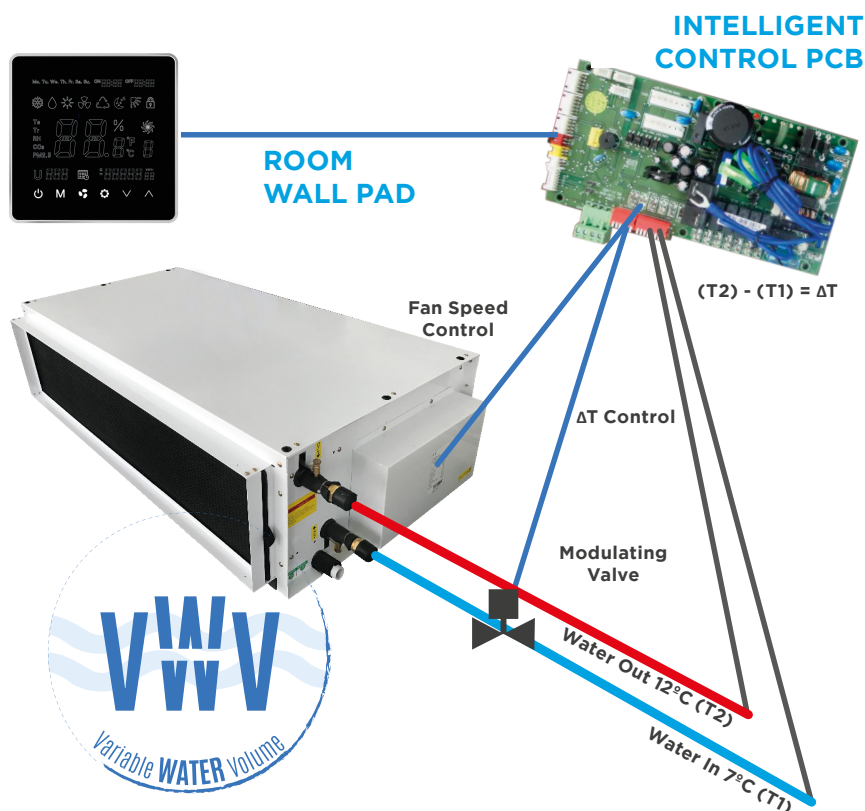

## IT IS ALL ABOUT **SERVICING OUR CUSTOMERS**

We pride ourselves on being more than just a provider; we're your partner in creating the ideal indoor climate for your well-being and sustainability goals. With a deep commitment to your satisfaction and comfort, we offer a range of services designed to make your experience seamless.

### 01. PRE-SALES

---

- **Product Consultation and Needs Assessment:** Collaborating closely with clients to comprehensively assess their unique requirements, ensuring a precise understanding of their needs.
- **Product System Design and Engineering Consultancy:** Crafting tailored product system designs that precisely match client specifications, coupled with expert technical support and responses to client inquiries about our product offerings.
- **Budget Estimation:** Furnishing clients with meticulous and transparent cost estimates for all necessary equipment, enabling them to make informed budgeting decisions.
- **Logistics Consultation:** Offering **container loading and freight calculation** to recommend the optimal logistics strategies to ensure efficient and timely delivery of the equipment to project locations.
- **Financing Options:** Empowering clients with financial guidance and assistance in exploring a range of payment options, facilitating project funding in alignment with their budgetary preferences.
- **Technical Support:** Providing ongoing technical expertise, guidance, and assistance to address client inquiries, troubleshoot issues, and optimize the performance of our systems, thus ensuring their continued satisfaction and success.

### 02. AFTER-SALES

---

- **Spare Part Supply:** Offering a comprehensive inventory of replacement components and parts, ensuring the equipment's consistent performance and prolonged lifespan.
- **Warranty Support:** Going the extra mile in assisting clients with warranty claims, we ensure that they not only avail themselves of the full benefits of manufacturer warranties but also experience a seamless and hassle-free warranty process.
- **Extended Warranty Options:** Providing clients with the flexibility to choose extended warranty options, granting them added peace of mind and long-term protection for their Polar Air systems.
- **Training and Education:** Empowering client personnel with in-depth training programs, equipping them with the knowledge and skills to operate and maintain Polar Air systems efficiently. This investment in education enhances system performance, reduces operational downtime, and optimizes the overall experience with our products.

## PASELECT SOFTWARE TO MAXIMIZE DESIGN EFFICIENCY

Our intuitive software is designed to empower HVAC professionals in the field. It provides precise calculations, efficiency data, and competitive project-specific offers, enabling you to optimize your HVAC system design for maximum efficiency. With the ability to filter and search units based on specific conditions and requirements for your space, our software streamlines the decision-making process, saving you time and effort.

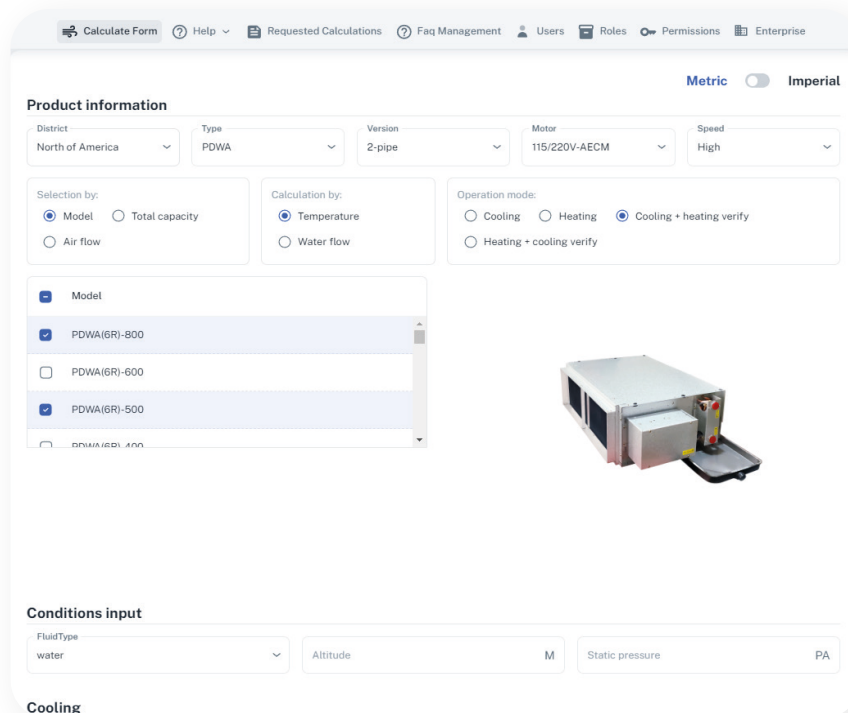



OUR  
FAN COILS



## PHW - HIGHWALL FAN COIL



### FEATURES

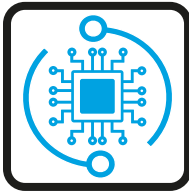

#### CONTROL FLEXIBILITY

Two types of control system: Intelligent control board (I-Control) controlled via Infra-red handset and/or Intelligent wired wall pad or Flexible control (W-Control) permitting operation with external thermostat applications both controls allows configuration for 2 or 4-pipe settings.



#### INTEGRATED VALVES

Optional 2 or 3-way both On/Off and modulating thermoelectric integrated valves located in a new position for easier maintenance. Synthetic elastomer tubes with stainless steel outer braiding and brass connectors, to enable quick and low-cost connections with no brazing.

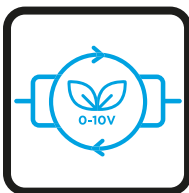

#### EFFICIENT EC MOTOR

EC motors allow the tangential blower wheel to operate at optimum airflow performance, energy efficiency and quiet operation. EC motors include driven control PCB, constant torque, permanent magnet and 3 speeds pre-set or modulating with a 0-10 VDC signal for precise air balancing control.



## CASING

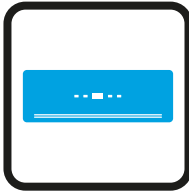

New stylish design built of durable flame-resistant ABS white color plastic, with rounded corners to give modern aesthetics and integrated LED display. Housed in only two casing sizes, to allow consistency and uniformity on projects where multiple units are required.

## WATER COILS

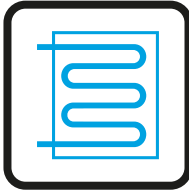

Built with seamless copper tubes and headers, mechanically expanded into corrugated aluminium fin material for a permanent primary to secondary surface bond. Tested at 500 psi, with maximum operating limits at 300 psi.

## READY TO INSTALL

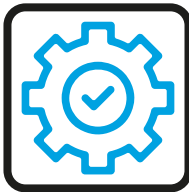

The PHW range is offered as a complete package including standard items such as internal drain pan, NBR insulation, and MERV 4 filter.

Furthermore, we offer multiple optional accessories.

## KEY POINTS

- High latent performance- dehumidification
- Auto Dynamic Balancing with I-control
- Easy maintenance accessibility



## ACCESSORIES

- IR Handset or Wired Wall Pad (Available with I-Control)
- Thermostat Controller (Available with W-Control)
- 2 or 3 Way On/Off & Modulating Valves
- Integrated Sauermann Condensate Pump
- Electric heater up to 1.5kW

\*Please refer to page 86 for further information and accessories.

# TECHNICAL SPECIFICATIONS

## Hydronic Highwall, 2 pipe with EC Motor

UNIT GENERAL SPECS	PHW-[Size]-V-AECM		200	300	400	500	600	750	
	Configuration		2-pipe						
	Number of Fan Blowers		Single						
	Power Supply (V/Ph/Hz)		208-240/1/60 or 110-120/1/60						
AIR	Total Air Flow	H	CFM	223	323	400	464	617	735
		M		159	223	323	353	500	600
		L		118	159	200	224	300	353
COOLING	Cooling Capacity	H	BTU/Hr	6243	8499	11136	14767	17017	22200
		M		4824	6479	9606	12102	14381	18927
		L		3800	4939	6564	8508	9774	12577
	Sensible Cooling Capacity	H		4255	5869	7657	9980	11587	15126
		M		3241	4391	6522	8048	9670	12708
		L		2507	3295	4367	5538	6427	8251
HEATING	Heating Capacity	H	BTU/Hr	9705	13212	17311	22957	26454	34509
		M		7499	10072	14933	18813	22357	29422
		L		5908	7678	10205	13226	15195	19552
	Max. Electric Heater Capacity @ 115V		kw	0.5		0.75			
Max. Electric Heater Capacity @ 220V		1		1.5					
SOUND	Pressure Level (H/M/L)		dB(A)	33/27/25	42/33/27	47/42/27	50/45/33	50.2/45.3/32	53/48/36
	Power Level (H/M/L)			42/36/34	51/42/36	56/51/36	59/54/42	59.2/54.3/41	62/57/45
ELECTRICAL	Power Input	H	W	13	20	30	38	50	65
		M		9	13	20	25	31	40
		L		7	9	11	13	12	16
	Running Current 115V (H)		A	0.31	0.23	0.38	0.52	0.52	0.7
Running Current 220V (H)		0.16		0.12	0.2	0.27	0.27	0.36	
HYDRONIC	Cooling Water Flow Rate	H	GPM	1.23	1.7	2.2	2.9	3.4	4.4
		M		0.95	1.3	1.9	2.4	2.8	3.7
		L		0.75	1	1.3	1.7	1.9	2.5
	Cooling Pressure Drop	H	Ft. hd.	2.69	2.6	3.9	5.3	8.7	15
		M		1.69	1.6	3	3.7	6.4	11.3
		L		1.1	1	1.5	2	3.2	5.4
	Heating Water Flow Rate	H	GPM	Same as cooling water flow rate					
		M		Same as cooling water flow rate					
		L		Same as cooling water flow rate					
	Heating Pressure Drop	H	Ft. hd.	2.42	2.3	3.5	4.8	7.8	13.5
M		1.52		1.4	2.7	3.4	5.8	10.1	
L		0.99		0.9	1.4	1.8	2.9	4.9	
Water Content		Gal	0.02	0.14	0.14	0.22	0.28	0.27	

### TESTING CONDITIONS (RATED AT AHRI STANDARD 440):

#### a. Cooling mode (2-pipe/ 4-pipe):

- Return air temperature: DB 80°F/WB 67°F
- Inlet/ outlet water temperature: 45°F/ 55°F

#### b. Heating mode (2-pipe):

- Return air temperature: 70°F
- Inlet water temperature: 140°F
- Water flow-rate: Same as cooling mode

(All dimensions are approximate within 1/16 of an inch of those indicated)

# TECHNICAL SPECIFICATIONS

## Hydronic Highwall, 4 pipe with EC Motor

UNIT GENERAL SPECS	PHW-[Size]-P-AECM			500	750
	Configuration			4-pipe	
	Number of Fan Blowers			Single	
	Power Supply (V/Ph/Hz)			208-240/1/60 or 110-120/1/60	
AIR	Total Air Flow	H	CFM	464	735
		M		353	600
		L		224	353
COOLING	Cooling Capacity	H	BTU/Hr	10623	16566
		M		8706	14124
		L		6120	9385
	Sensible Cooling Capacity	H		7099	11067
		M		5725	9297
		L		3939	6036
HEATING	Heating Capacity	H	BTU/Hr	8793	12614
		M		7156	10693
		L		5036	7156
SOUND	Pressure Level (H/M/L)		dB(A)	38	65
	Power Level (H/M/L)			25	40
ELECTRICAL	Power Input	H	W	13	16
		M		0.52	0.7
		L		0.27	0.36
	Running Current 115V (H)		A	50/45/33	53/48/36
	Running Current 220V (H)			59/54/42	62/57/45
HYDRONIC	Cooling Water Flow Rate	H	GPM	2.1	3.3
		M		1.7	2.8
		L		1.2	1.8
	Cooling Pressure Drop	H	Ft. hd.	5.7	14.27
		M		4	10.71
		L		2.1	5.13
	Heating Water Flow Rate	H	GPM	0.44	0.63
		M		0.78	1.16
		L		0.55	0.78
	Heating Pressure Drop	H	Ft. hd.	0.6	1.15
		M		0.42	0.86
		L		0.22	0.42
Chilled Water Content		Gal	0.2	0.25	
Hot Water Content			0.076	0.095	

### TESTING CONDITIONS (RATED AT AHRI STANDARD 440):

#### a. Cooling mode (2-pipe/ 4-pipe):

- Return air temperature: DB 80°F/WB 67°F
- Inlet/ outlet water temperature: 45°F/ 55°F

#### b. Heating mode (4-pipe):

- Return air temperature: 70°F
- Inlet water temperature: 180°F/140°F

(All dimensions are approximate within 1/16 of an inch of those indicated)

# DIMENSIONAL DRAWINGS, DATA & WEIGHTS

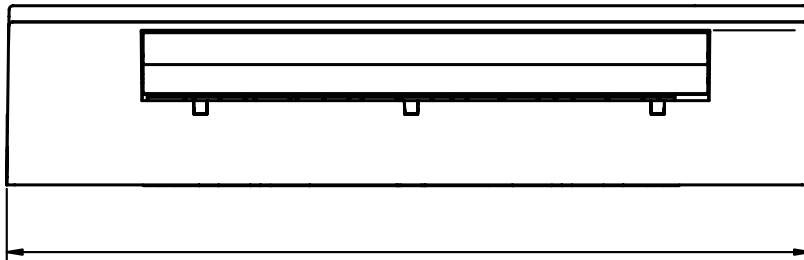
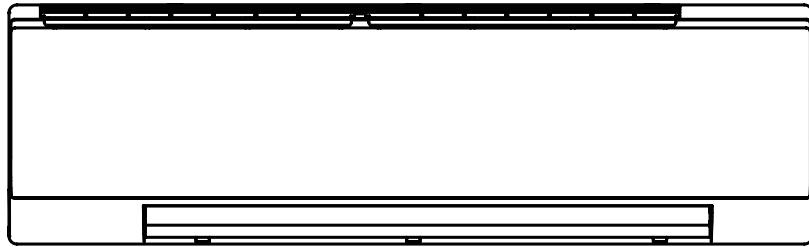

L

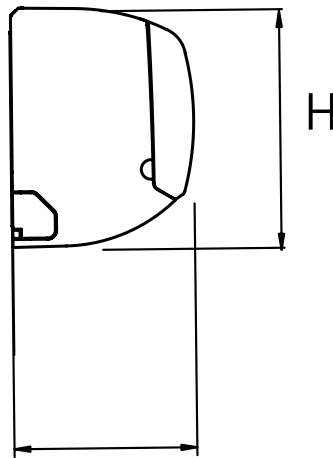

W

PHW			200	300	400	500	600	750
CONSTRUCTION AND PACKING DATA	Water Connections	Type	MNPT (Threaded Male from the hose)					
		In	1/2					
	Out	5/8						
	Condensate Drainage	L	39 3/4			46 1/4		
		W	9 1/16					
H		11 13/16						
WEIGHT	Net Weight	lbs	26.5	30.9	33.1	37.5	39.7	41.9

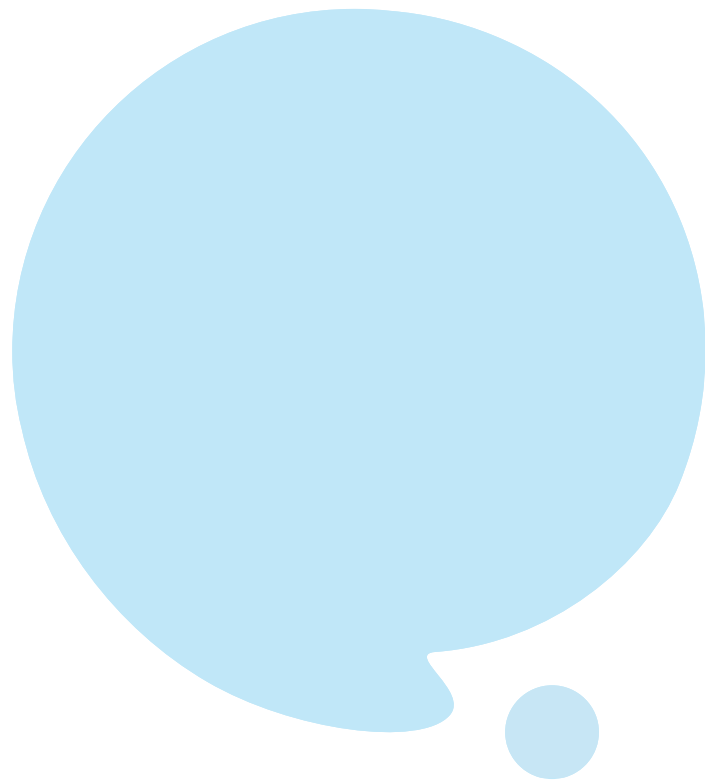

# PCGH-3R - 4 WAY CASSETTE



## FEATURES

### CONTROL FLEXIBILITY

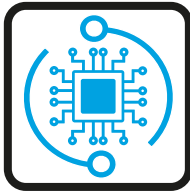

Two types of control system: Intelligent control board (I-Control) controlled via Infra-red handset and/or Intelligent wired wall pad or Flexible control (W-Control) permitting operation with external thermostat applications both controls allows configuration for 2 or 4-pipe settings.

### EFFICIENT EC MOTOR

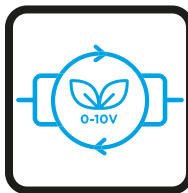

EC motors allow the centrifugal fan to operate at optimum airflow performance, energy efficiency and quiet operation. EC motors include driven control PCB, constant torque, permanent magnet and 3 speeds pre-set or modulating with a 0-10 VDC signal for precise air balancing control.

### FAN BLOWER

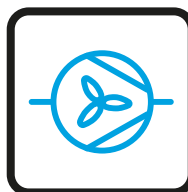

Backward-curved centrifugal fan, statically and dynamically balanced to operate at optimum 4 way airflow performance, energy efficiency and quiet operation. Fire-retardant plastic fan impellers for lightweight and corrosion-resistant operation.



## CASING

Enclosure constructed from galvanized steel, integral fan mounting rails, and internal fire resistant insulation. Front panel is made from high impact polystyrene RAL 9010 ensuring durability and a sleek appearance.

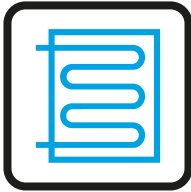

## WATER COILS

Built with seamless copper tubes and headers, mechanically expanded into corrugated aluminium fin material for a permanent primary to secondary surface bond. Tested at 500 psi, with maximum operating limits at 300 psi.



## READY TO INSTALL

The PCGH-3R range is offered as a complete package including as standard items such as an integrated Sauermann Condensate Pump, Internal drain pan, NBR insulation and MERV 4 filter. Furthermore, we offer multiple optional accessories.

## KEY POINTS

- Plug and play control box
- Auto Dynamic Balancing with I-Control
- High Cooling capacity up to 51 MBH



## ACCESSORIES

- IR Handset or Wired Wall Pad (Available with I-Control)
- Thermostat Controller (Available with W-Control)
- Electric heater up to 3kW
- 2 or 3 Way On/Off & Modulating Valves
- Belimo Valve Kit
- Plastic Fresh Air Intake Flange
- MERV 8 filter

\*Please refer to page 86 for further information and accessories.



# TECHNICAL SPECIFICATIONS

Hydronic 4 way Cassette; 3R; 2 Pipe with **EC Motor**

UNIT GENERAL SPECS		PCG(H)-3R-[Size]-V-AECM			04	08	12	20	24
		Configuration			2-pipe				
Number of Fan Blowers			Single						
Power Supply (V/Ph/Hz)			110-120/1/60 208-240/1/60						
AIR	Total Air Flow	H	CFM	338	476	765	1300	1618	
		M		224	425	618	941	1494	
		L		118	118	212	482	600	
COOLING	Cooling Capacity	H	BTU/Hr	11907	17236	24201	37785	50990	
		M		8762	15478	20606	31527	48387	
		L		5220	5443	8526	18830	23557	
	Sensible Cooling Capacity	H		7880	11463	16230	25286	34245	
		M		5687	10246	13677	20843	32386	
		L		3323	3517	5556	12154	15168	
HEATING	Heating Capacity	H	BTU/Hr	18509	26794	37622	58739	79266	
		M		13621	24062	32034	49010	75219	
		L		8115	8462	13255	29272	36620	
	Max. Electric Heater Capacity @ 115V		kw	0.5	1	1.5	2	2	
	Max. Electric Heater Capacity @ 220V			1	2	3	4	4	
SOUND	Pressure Level (Outlet)		dB(A)	43/39/27	50/40/26	56/53/32	58/53/37	64/61/41	
	Power Level (Outlet)			52/48/36	59/49/35	65/62/41	67/63/44	73/70/50	
ELECTRICAL	Power Input	H	W	21	47	82	140	220	
		M		14.8	18	67	100	178	
		L		11	11	16	27	50	
	Running Current 115V (H)		A	0.37	0.82	1.43	2.44	3.83	
	Running Current 220V (H)			0.19	0.43	0.75	1.27	2	
HYDRONIC	Cooling Water Flow Rate	H	GPM	2.35	3.4	4.78	7.81	10.07	
		M		1.73	3.06	4.07	6.23	9.56	
		L		1.03	1.07	1.68	3.72	4.65	
	Cooling Pressure Drop	H	Ft. hd.	12.08	15.05	16.8	12.72	16.53	
		M		6.95	12.4	12.58	9.18	15.05	
		L		2.74	1.89	2.57	3.63	4.12	
	Heating Water Flow Rate	H	GPM	Same as cooling water flow rate					
		M							
		L							
	Heating Pressure Drop	H	Ft. hd.	10.87	13.55	15.12	12.44	14.88	
		M		6.26	11.16	11.32	8.26	13.54	
L		2.46		1.7	2.31	3.27	3.71		
Water Content		Gal	0.33	0.41	0.47	0.64	0.79		

**TESTING CONDITIONS (RATED AT AHRI STANDARD 440):**

**a. Cooling mode (2-pipe/ 4-pipe):**

- Return air temperature: DB 80°F/WB 67°F
- Inlet/ outlet water temperature: 45°F/ 55°F

**b. Heating mode (2-pipe):**

- Return air temperature: 70°F
- Inlet water temperature: 140°F
- Water flow-rate: Same as cooling mode



# TECHNICAL SPECIFICATIONS

Hydronic 4 way Cassette; 3R; 4 Pipe with **EC Motor**

UNIT GENERAL SPECS	PCG(H)-3R-[Size]-P-AECM		04	08	12	20	24	
	Configuration		4-pipe					
	Number of Fan Blowers		Single					
	Power Supply (V/Ph/Hz)		110-120/1/60 208-240/1/60					
AIR	Total Air Flow	H	CFM	338	476	765	1300	1618
		M		224	425	618	641	1494
		L		118	118	212	482	600
COOLING	Cooling Capacity	H	BTU/Hr	9408	13472	18493	28587	38476
		M		6923	12098	15746	23852	36512
		L		4125	4255	6515	14246	17776
	Sensible Cooling Capacity	H		6303	9092	12641	20492	26386
		M		4549	8126	10653	16053	24953
		L		2658	2789	4327	9361	11687
HEATING	Heating Capacity	H	BTU/Hr	11353	15318	22158	34154	45798
		M		8355	14069	18911	28562	42897
		L		4996	5138	8268	17064	21271
SOUND	Pressure Level (Outlet)		dB(A)	43/39/27	50/40/26	56/53/32	58/53/37	64/61/41
	Power Level (Outlet)			52/48/36	59/49/35	65/62/41	67/63/44	73/70/50
ELECTRICAL	Power Input	H	W	21	47	82	140	220
		M		14.8	18	67	100	178
		L		11	11	16	27	50
	Running Current 115V (H)		A	0.37	0.82	1.43	2.44	3.83
	Running Current 220V (H)			0.19	0.43	0.75	1.27	2
HYDRONIC	Cooling Water Flow Rate	H	GPM	1.86	2.66	3.65	5.65	7.6
		M		1.37	2.39	3.11	4.71	7.21
		L		0.81	0.84	1.29	2.81	3.51
	Cooling Pressure Drop	H	Ft. hd.	11.72	11.97	11.54	9.62	11.14
		M		6.75	9.86	8.64	6.95	10.14
		L		2.66	1.5	1.76	2.75	2.77
	Heating Water Flow Rate	H	GPM	0.57	0.76	1.1	1.7	2.28
		M		0.42	0.7	0.94	1.42	2.14
		L		0.25	0.26	0.41	0.85	1.06
	Heating Pressure Drop	H	Ft. hd.	1.66	3.44	6.86	6.91	6.65
		M		0.96	2.95	5.16	5.01	5.91
		L		0.38	0.48	1.16	1.98	1.67
Chilled Water Content		Gal	0.22	0.27	0.31	0.43	0.53	
Hot Water Content			0.11	0.14	0.16	0.21	0.26	

### TESTING CONDITIONS (RATED AT AHRI STANDARD 440):

#### a. Cooling mode (2-pipe/ 4-pipe):

- Return air temperature: DB 80°F/WB 67°F
- Inlet/ outlet water temperature: 45°F/ 55°F

#### b. Heating mode (4-pipe):

- Return air temperature: 70°F
- Inlet water temperature: 180°F/140°F

(All dimensions are approximate within 1/16 of an inch of those indicated)

# DIMENSIONAL DRAWINGS, DATA & WEIGHTS

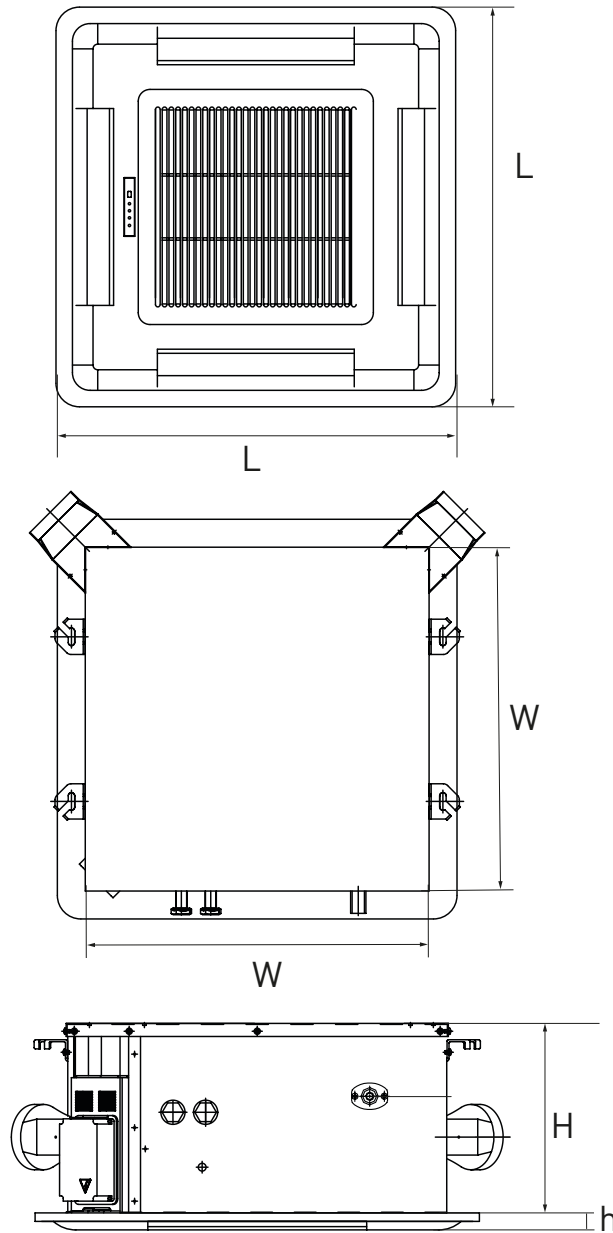

PCGH			04	08	12	20	24
CONSTRUCTION AND PACKING DATA	Water Connections	Type	FNPT (Threaded Female)				
		In	3/4				
	Condensate Drainage	Out	Outside diameter: 1 Inside diameter: 13/16				
		L	22-15/16	28-3/4	32-11/16	37-13/16	
	Unit Dimensions	W	10-1/16	11-7/16	10-1/4	11-7/16	
		H	10-1/16	11-7/16	10-1/4	11-7/16	
h		26-3/4	32-11/16	38-9/16	44-7/8		
Panel Dimensions	W	1-1/8					
	h	1-1/8					
WEIGHT	Net Weight	lbs	62	66	79	110	119

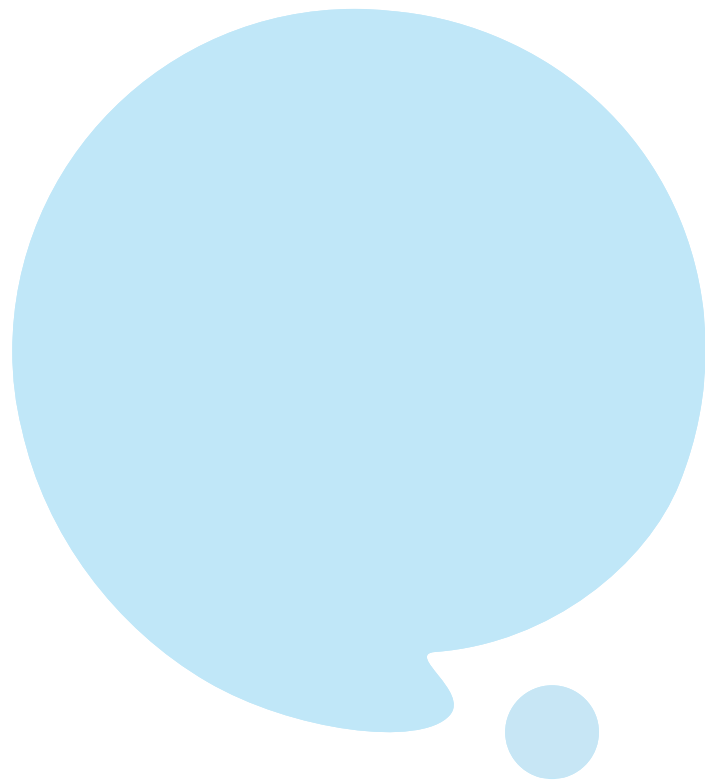

# PDWSL - SLIM ESP DUCTED



## FEATURES

### CONTROL FLEXIBILITY

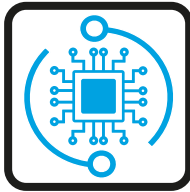

Two types of control system: Intelligent control board (I-Control) controlled via Infra-red handset and/or Intelligent wired wall pad or Flexible control (W-Control) permitting operation with external thermostat applications both controls allows configuration for 2 or 4-pipe settings.

### EFFICIENT EC MOTOR

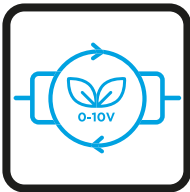

EC motors allow the centrifugal fans to operate at optimum airflow performance, energy efficiency and quiet operation. EC motors include driven control PCB, constant torque, permanent magnet and 3 speeds pre-set or modulating with a 0-10 VDC signal for precise air balancing control.

### FAN BLOWER

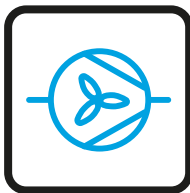

Optimized forward-curved metal centrifugal fans made from heavy-gauge galvanized steel with die-formed inlet cones housings, statically and dynamically balanced for smooth and quiet operation.

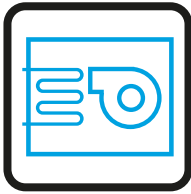

## STRUCTURE

7 7/8" low height design, perfect for reduced space concealed installations, Made from heavy-gauge galvanized steel panels with couplings for the connection of ducting and gravity drain pan with insulation for condensation.



## WATER COILS

Built with seamless copper tubes and headers, mechanically expanded into corrugated aluminium fin material for a permanent primary to secondary surface bond. Tested at 500 psi, with maximum operating limits at 300 psi.



## READY TO INSTALL

The PDWSL range is offered as a complete package including standard items such as an integrated Condensate Pump, 0.2" NBR Insulation, and a MERV 4 filter. Furthermore, we offer multiple optional accessories.

## KEY POINTS

- Slim design with 7 7/8" height
- Integrated condensate pump
- Auto Dynamic Balancing with I-Control
- Quiet operation



## ACCESSORIES

- IR Handset or Wired Wall Pad (Available with I-Control)
- Thermostat Controller (Available with W-Control)
- Merv 8 Filter
- Electric heater up to 3kW
- Additional NBR Insulation up to 1"
- Stainless Steel drain pan
- 2 or 3 Way On/Off & Modulating Valves
- Belimo Valve Kit

\*Please refer to page 86 for further information and accessories.

# TECHNICAL SPECIFICATIONS

Hydronic Slim Ducted Unit, 3R; 2 Pipe with **EC Motor**

UNIT GENERAL SPECS	PDWSL-3R-[Size]-V-AECM			01	02	03
	Configuration			2-pipe		
	Number of Fan Blowers			2	3	4
	Power Supply (V/Ph/Hz)			110-120 / 1 / 60 208-240 / 1 / 60		
AIR	Total Air Flow	H	CFM	351	539	726
		M		254	379	506
		L		101	155	225
	External Static Pressure	H	in.wg	0.05		
		M				
		L				
COOLING	Total Cooling Capacity	H	BTU/Hr	10150	16124	21426
		M		7807	12174	16178
		L		3667	5921	8407
	Sensible Cooling Capacity	H		6812	10778	14340
		M		5186	8045	10704
		L		2425	3900	5559
HEATING	Heating Capacity	H	BTU/Hr	15779	25066	33308
		M		12137	18926	25149
		L		5701	9205	13069
	Max. Electric Heater Capacity @ 220V		kw	1	2	3
Max. Electric Heater Capacity @ 115V		0.5		1	1.5	
SOUND	Pressure Level (Outlet)		dB(A)	43/37/22	45/40/25	46/41/26
	Pressure Level (Inlet + Radiated)			46/40/25	48/43/28	49/44/26
	Power Level (Outlet)			52/46/31	54/49/34	55/50/35
	Power Level (Inlet + Radiated)			55/49/34	57/52/37	58/53/38
ELECTRICAL	Power Input	H	W	42	70	84
		M		23	40	43
		L		11	15	17
	Running Current 115V (H)		A	0.73	1.22	1.46
Running Current 220V (H)		0.381		0.63	0.76	
HYDRONIC	Cooling Water Flow Rate	H	GPM	2	3.18	4.23
		M		1.54	2.4	3.19
		L		0.72	1.17	1.66
	Cooling Pressure Drop	H	ft.wg	9.62	10.31	9.58
		M		6	6.22	5.78
		L		1.23	1.36	1.42
	Heating Water Flow Rate	H	GPM	Same as cooling water flow rate		
		M				
		L				
	Heating Pressure Drop	H	ft.wg	8.66	9.28	8.62
M		5.4		5.6	5.2	
L		1.39		1.53	1.6	
Water Content		gal	0.21	0.35	0.48	

**TESTING CONDITIONS (RATED AT AHRI STANDARD 440):**

**a. Cooling mode (2-pipe):**

- Return air temperature: DB 80°F/WB 67°F
- Inlet/ outlet water temperature: 45°F/ 55°F

**b. Heating mode (2-pipe):**

- Return air temperature: 70°F
- Inlet water temperature: 140°F
- Water flow-rate: Same as cooling mode

(All dimensions are approximate within 1/16 of an inch of those indicated)

# TECHNICAL SPECIFICATIONS

Hydronic Slim Ducted Unit, 3R+1 (Auxiliary Heating Coil); 4 Pipe with **EC Motor**

UNIT GENERAL SPECS	PDWSL-3R+1-[Size]-P-AECM			01	02	03
	Configuration			4-pipe		
	Number of Fan Blowers			2	3	4
	Power Supply (V/Ph/Hz)			110-120 / 1 / 60 208-240 / 1 / 60		
AIR	Total Air Flow	H	CFM	364	553	735
		M		266	397	523
		L		103	143	181
	External Static Pressure	H	in.wg	0.05		
		M				
		L				
COOLING	Total Cooling Capacity	H	BTU/Hr	10435	16420	21819
		M		8120	12663	16610
		L		3797	5516	7061
	Sensible Cooling Capacity	H		7017	10990	14622
		M		5411	8393	11018
		L		2515	3623	4635
HEATING	Heating Capacity	H	BTU/Hr	9716	15205	20342
		M		7561	11726	15486
		L		3536	5108	6583
SOUND	Pressure Level (Outlet)		dB(A)	43/37/22	45/40/25	46/41/26
	Pressure Level (Inlet + Radiated)			46/40/25	48/43/28	49/44/26
	Power Level (Outlet)			52/46/31	54/49/34	55/50/35
	Power Level (Inlet + Radiated)			55/49/34	57/52/37	58/53/38
ELECTRICAL	Power input	H	W	42	70	84
		M		23	40	43
		L		11	15	17
	Running Current 115V (H)		A	0.73	1.22	1.46
	Running Current 220V (H)			0.381	0.63	0.76
HYDRONIC	Cooling Water Flow Rate	H	GPM	2.06	3.24	4.31
		M		1.6	2.5	3.28
		L		0.75	1.09	1.39
	Cooling Pressure Drop	H	ft.wg	10.11	10.66	9.9
		M		6.44	6.88	6.06
		L		1.64	1.5	1.3
	Heating Water Flow Rate	H	GPM	0.48	0.76	1.01
		M		0.38	0.58	0.77
		L		0.18	0.25	0.33
	Heating Pressure Drop	H	ft.wg	1.23	0.58	1.23
		M		0.78	0.37	0.75
		L		0.2	0.08	0.16
Chilled Water Content		gal	0.21	0.35	0.48	
Hot Water Content			0.12	0.16	0.16	

## TESTING CONDITIONS (RATED AT AHRI STANDARD 440):

### a. Cooling mode (2-pipe/ 4-pipe):

- Return air temperature: DB 80°F/WB 67°F
- Inlet/ outlet water temperature: 45°F/ 55°F

### b. Heating mode (4-pipe):

- Return air temperature: 70°F
- Inlet water temperature: 180°F/140°F

(All dimensions are approximate within 1/16 of an inch of those indicated)

# DIMENSIONAL DRAWINGS, DATA & WEIGHTS

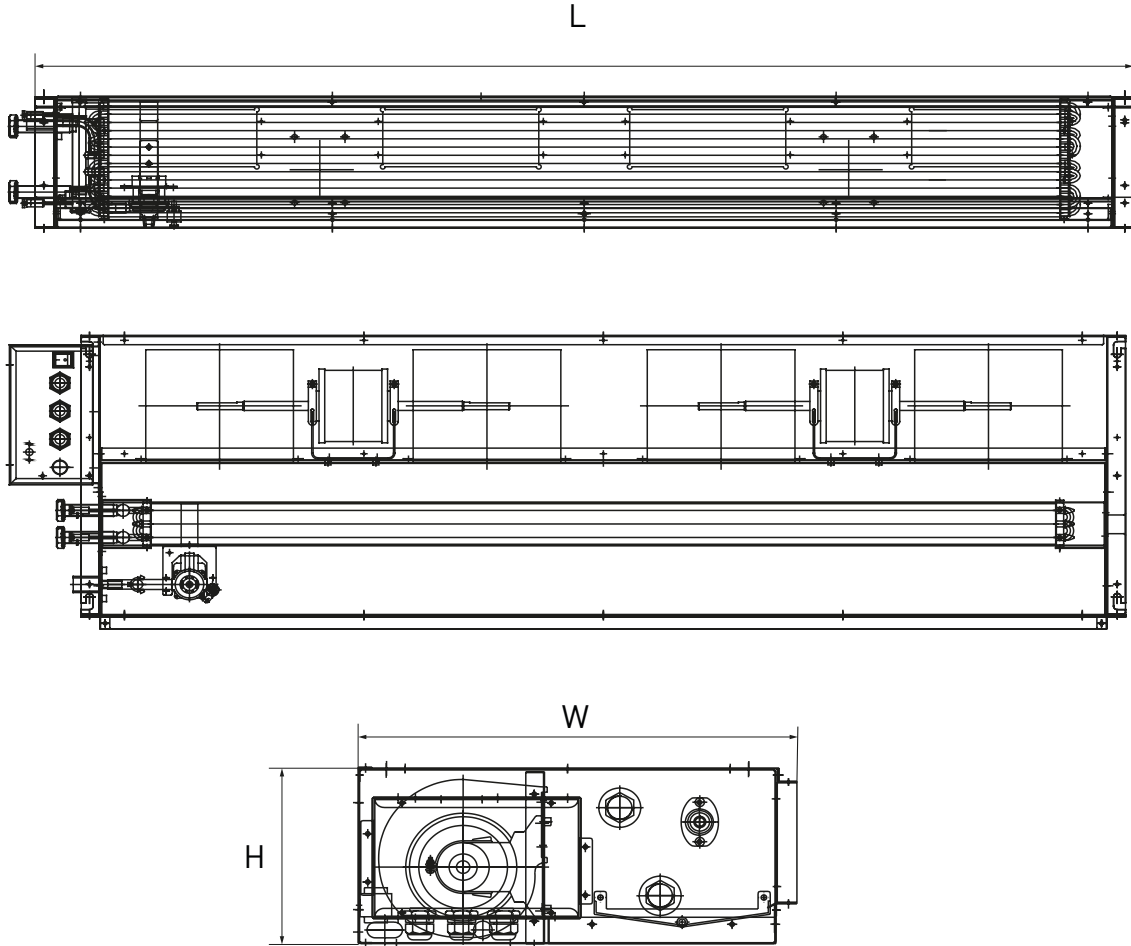

PDWSL			01	02	03
CONSTRUCTION AND PACKING DATA	Cooling Water Connections <sup>T</sup>	Type	FNPT (Threaded Female)		
		In		3/4	
	Out				
	Condensate Drainage			1	
	Heating Water Connections (Only 4 pipes)	In			
		Out		1/2	
	Dimensions	L		31 1/2	48 5/8
W				18 1/2	
H				7 7/8	
WEIGHT	Net Weight	lbs	44	62	77



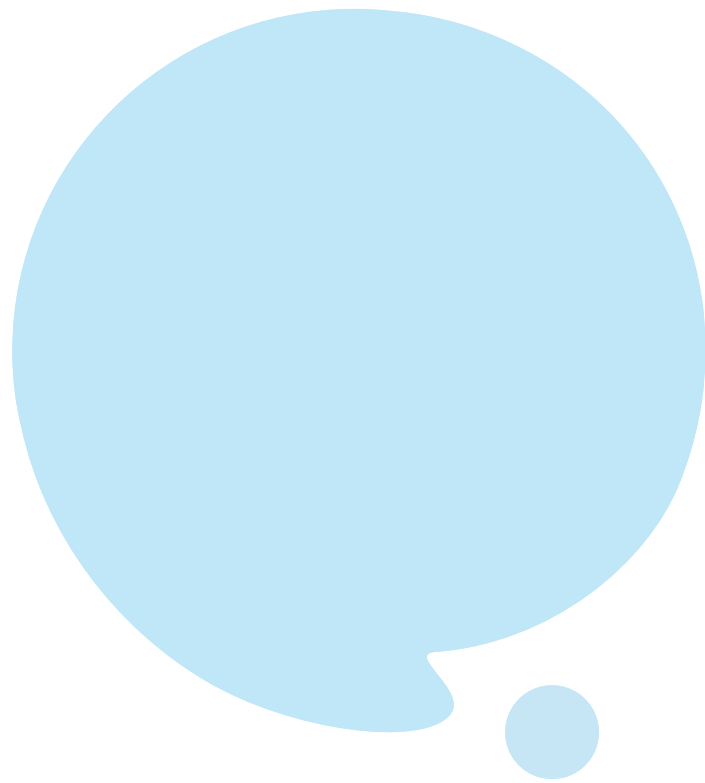

# PDWA - MEDIUM ESP DUCTED

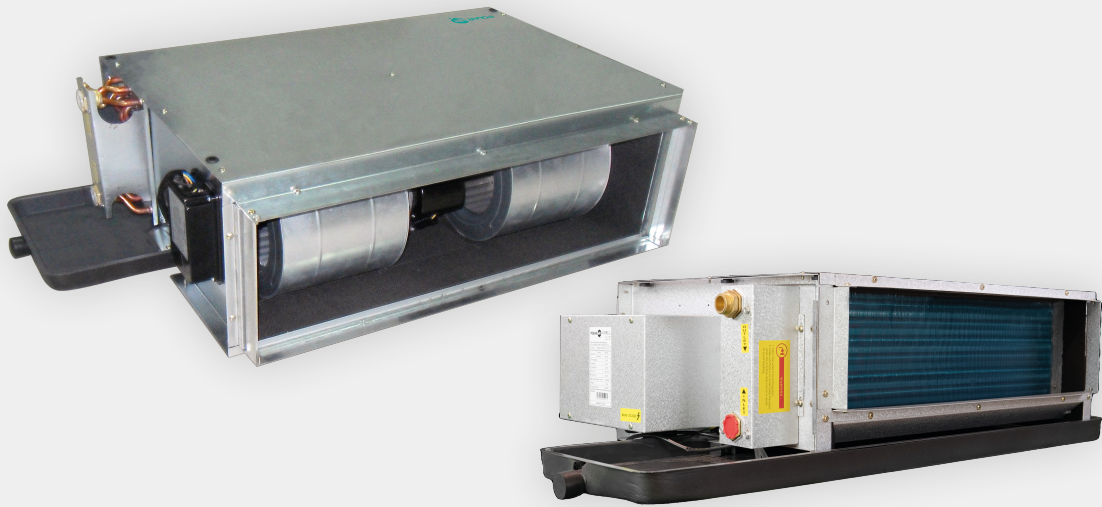

## FEATURES

### CONTROL FLEXIBILITY

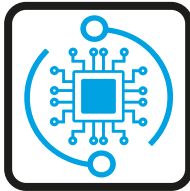

Two types of control system: Intelligent control board (I-Control) controlled via Infra-red handset and/or Intelligent wired wall pad or Flexible control (W-Control) permitting operation with external thermostat applications both controls allows configuration for 2 or 4-pipe settings.

### EFFICIENT EC MOTOR



EC motors allow the centrifugal fans to operate at optimum airflow performance, energy efficiency and quiet operation. EC motors include driven control PCB, constant torque, permanent magnet and 3 speeds pre-set or modulating with a 0-10 VDC signal for precise air balancing control.

### FAN BLOWER

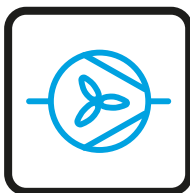

Optimized forward-curved metal centrifugal fans made from heavy-gauge galvanized steel with die-formed inlet cones housings, statically and dynamically balanced for smooth and quiet operation.

## STRUCTURE

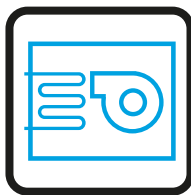

Made from heavy-gauge galvanized steel panels with couplings for the connection of ducting and gravity drain pan with insulation for condensation. Compact dimensions with optimum thermal and electrical efficiency for all types of applications.

## WATER COILS



Built with seamless copper tubes and headers, mechanically expanded into corrugated aluminium fin material for a permanent primary to secondary surface bond. Tested at 500 psi, with maximum operating limits at 300 psi.

## READY TO INSTALL



The PDWA range is offered as a complete package including standard items such as a Powder-coated steel external drain pan, NBR insulation of 0.2", and a MERV 4 filter. Furthermore, we offer multiple optional accessories.

## KEY POINTS

- Auto Dynamic Balancing with I-Control
- External Static Pressure up to 0.52 in.wg
- Coil interchangeable on field
- 3, 4 and 6 Row configurations available



## ACCESSORIES

- IR Handset or Wired Wall Pad (Available with I-Control)
- Thermostat Controller (Available with W-Control)
- Merv 8 Filter
- Electric heater up to 6kW
- Additional NBR Insulation up to 1"
- Stainless Steel Drain Pan
- 2 or 3 Way On/Off & Modulating Valves
- Belimo Valve Kit
- Integrated Sauermann Condensate Pump
- Supply/Return air Plenum

\*Please refer to page 86 for further information and accessories.



# TECHNICAL SPECIFICATIONS

Hydronic Medium ESP Ducted Unit; 3R, 2 Pipe with **EC Motor**

UNIT GENERAL SPECS		PDWA-3R-[Size]-V-AECM		200	300	400	500	600	800	1000	1200	1400	1600		
		Configuration		2-pipe											
		Number of Fan Blowers		Single			Twin			Three			Four	Three	Four
		Power Supply (V/Ph/Hz)		110-120/1/60 208-240/1/60											
AIR	Total Air Flow	H	CFM	278	369	510	575	698	979	1090	1239	1773	2365		
		M		221	330	429	449	594	742	946	1161	1670	2227		
		L		166	241	246	337	486	579	757	967	1215	1620		
AIR	External Static Pressure	H	in.wg	0.2											
		M		0.2											
		L		0.2											
COOLING	Total Cooling Capacity	H	BTU/Hr	8910	11670	15129	17351	19984	30579	31199	35309	49241	59004		
		M		7524	10718	13261	14368	17810	24660	28081	33558	47205	56709		
		L		6013	8414	8566	11507	15147	20479	23616	29238	37075	44349		
	Sensible Cooling Capacity	H	BTU/Hr	6066	7917	10414	11844	13558	20793	21473	24267	33880	40445		
		M		5053	7245	9074	9660	11947	16514	19173	23011	32378	38739		
		L		4001	5588	5713	7676	10099	13604	15945	19792	24999	29773		
HEATING	Heating Capacity	H	BTU/Hr	13851	18142	23519	26973	31067	47536	48500	54890	76547	91724		
		M		11697	16662	19846	22335	27687	44052	44000	52556	64583	71821		
		L		9347	13079	13317	17888	23456	31835	36712	45452	57635	68943		
	Max. Electric Heater Capacity @ 115V Max. Electric Heater Capacity @ 220V	kw	1			1.5	2	2.5			3				
2			3	4	5			6							
SOUND	Pressure Level (outlet)	dB(A)	48/47/43	50/49/46	52/50/44	52/51/46	54/52/49	53/52/47	56/54/50	58/55/52	58/54/50	59/57/55			
	Pressure Level (Inlet + Radiated)		50/49/45	52/51/48	54/52/46	54/53/48	56/54/51	55/54/49	58/56/52	60/57/54	60/56/52	61/59/57			
	Power Level (outlet)		57/56/52	59/58/55	61/59/53	61/60/55	63/61/58	62/61/56	65/63/59	67/64/61	67/63/59	68/66/64			
	Power Level (Inlet + Radiated)		59/58/54	61/60/57	63/61/55	63/62/57	65/63/60	64/63/58	67/65/61	69/66/63	69/65/61	70/68/66			
ELECTRICAL	Power Input	H	W	53	63	83	96	102	150	180	224	363	380		
		M		43	52	58	68	84	128	147	190	286	310		
		L		26	31	35	49	62	84	94	113	170	190		
	Running Current 115V (H)	A	0.92	1.1	1.44	1.67	1.77	2.61	3.13	3.9	6.31	6.61			
Running Current 220V (H)	0.48		0.57	0.75	0.87	0.93	1.36	1.64	2.04	3.3	3.45				
HYDRONIC	Cooling Water Flow Rate	H	GPM	1.76	2.3	2.99	3.43	3.95	6.04	6.16	6.97	9.72	11.65		
		M		1.49	2.12	2.62	2.84	3.52	4.87	5.55	6.63	9.32	11.2		
		L		1.19	1.66	1.69	2.27	2.99	4.04	4.66	5.77	7.32	8.76		
	Cooling Pressure Drop	H	Ft. hd.	7.81	13.97	8.03	11.09	15.39	19.64	7.09	9.29	19.79	29.38		
		M		5.76	11.99	6.34	7.89	12.51	13.33	5.87	8.48	18.35	27.36		
		L		3.85	7.75	2.89	5.29	9.34	9.54	4.29	6.61	11.88	17.57		
	Heating Water Flow Rate	H	GPM	Same as cooling water flow rate											
		M		Same as cooling water flow rate											
		L		Same as cooling water flow rate											
	Heating Pressure Drop	H	Ft. hd.	7.03	12.58	7.23	9.98	13.85	17.67	6.38	8.36	17.82	26.44		
M		5.18		10.79	5.7	7.1	11.26	12	5.28	7.63	16.51	24.62			
L		3.46		6.98	2.6	4.76	8.41	8.59	3.87	5.95	10.69	15.82			
Water Content	Gal	0.19	0.19	0.23	0.27	0.31	0.35	0.51	0.55	0.59	0.68				

**TESTING CONDITIONS (RATED AT AHRI STANDARD 440):**

**a. Cooling conditions (2-pipe or 4-pipe)**

- Return air temperature: DB 80°F/WB 67°F.
- Inlet/ outlet water temperature: 45/55°F.

**b. Heating conditions (2-pipe)**

- Return air temperature: 70°F
- Inlet water temperature: 140°F
- Water flow-rate: Same as cooling mode

# TECHNICAL SPECIFICATIONS

Hydronic Medium ESP Ducted Unit; 4R, 2 Pipe with **EC Motor**

UNIT GENERAL SPECS			PDWA-4R-[Size]-V-AECM	200	300	400	500	600	800	1000	1200	1400	1600			
			Configuration		2-pipe											
			Number of Fan Blowers		Single			Twin			Three			Four	Three	Four
			Power Supply (V/Ph/Hz)		110-120/1/60											
			208-240/1/60													
AIR	Total Air Flow	H	CFM	259	350	479	543	662	920	1044	1188	1710	2281			
		M		205	315	403	419	567	692	909	1122	1621	2162			
		L		155	231	226	318	468	546	733	938	1182	1576			
	External Static Pressure	H	in.wg	0.2												
		M														
		L														
COOLING	Total Cooling Capacity	H	BTU/Hr	9500	12134	16361	19899	22922	31393	37780	42826	57924	69188			
		M		7952	11214	14290	16362	20486	25384	34005	40966	55849	66482			
		L		6411	8868	9190	13266	17587	20959	28896	35906	43864	52267			
	Sensible Cooling Capacity	H		6328	8056	10883	17425	15277	20896	25130	28483	39000	46595			
		M		5222	7420	9445	14108	13540	16633	22439	27191	37505	44731			
		L		4174	5767	5913	11351	11500	13629	18859	23529	28957	34649			
HEATING	Heating Capacity	H	BTU/Hr	14768	18862	25434	30934	35634	48802	58731	66575	90046	107556			
		M		12361	17432	22214	25435	31846	39461	52863	63683	86819	103350			
		L		9966	13786	14287	20623	27340	32581	44920	55818	68189	81251			
	Max. Electric Heater Capacity @ 115V Max. Electric Heater Capacity @ 220V	kw		1	1.5	2	2.5		3							
			2	3	4	5		6								
SOUND	Pressure Level (outlet)	dB(A)	48/47/43	50/49/46	52/50/44	52/51/46	54/52/49	53/52/47	56/54/50	58/55/52	58/54/50	59/57/55				
	Pressure Level (Inlet + Radiated)		50/49/45	52/51/48	54/52/46	54/53/48	56/54/51	55/54/49	58/56/52	60/57/54	60/56/52	61/59/57				
	Power Level (outlet)		57/56/52	59/58/55	61/59/53	61/60/55	63/61/58	62/61/56	65/63/59	67/64/61	67/63/59	68/66/64				
	Power Level (Inlet + Radiated)		59/58/54	61/60/57	63/61/55	63/62/57	65/63/60	64/63/58	67/65/61	69/66/63	69/65/61	70/68/66				
ELECTRICAL	Power Input	H	W	53	63	83	96	102	150	180	224	363	380			
		M		43	52	58	68	84	128	147	190	286	310			
		L		26	31	35	49	62	84	94	113	170	190			
	Running Current 115V (H)	A	0.92	1.1	1.44	1.67	1.77	2.61	3.13	3.9	6.31	6.61				
Running Current 220V (H)	0.48		0.57	0.75	0.87	0.93	1.36	1.64	2.04	3.3	3.45					
HYDRONIC	Cooling Water Flow Rate	H	GPM	1.88	2.4	3.23	3.93	4.53	6.2	7.46	8.46	11.44	13.66			
		M		1.57	2.21	2.82	3.23	4.05	5.01	6.72	8.09	11.03	13.13			
		L		1.27	1.75	1.81	2.62	3.47	4.14	5.71	7.09	8.66	10.32			
	Cooling Pressure Drop	H	Ft. hd.	11.7	19.92	37.29	18.84	26.24	27.33	40	52.9	34.8	51.93			
		M		8.49	17.28	29.22	13.25	21.43	18.65	33.09	48.83	32.59	48.34			
		L		5.76	11.33	13.2	9.08	16.29	13.21	24.69	38.52	21.1	31.35			
	Heating Water Flow Rate	GPM	Same as cooling water flow rate													
	Heating Pressure Drop	H	Ft. hd.	10.53	17.92	33.56	16.96	23.61	24.6	36	47.61	31.32	46.74			
		M		7.64	15.55	26.3	11.92	19.29	16.78	29.78	43.95	29.33	43.5			
		L		5.19	10.19	11.81	8.17	14.66	11.89	22.22	34.67	18.99	28.21			
Water Content	Gal	0.25	0.31	0.36	0.41	0.47	0.68	0.73	0.79	0.91	1					

### TESTING CONDITIONS (RATED AT AHRI STANDARD 440):

#### a. Cooling conditions (2-pipe or 4-pipe)

- Return air temperature: DB 80°F/WB 67°F.
- Inlet/ outlet water temperature: 45/55°F.

#### b. Heating conditions (2-pipe)

- Return air temperature: 70°F
- Inlet water temperature: 140°F
- Water flow-rate: Same as cooling mode

(All dimensions are approximate and within 1/16 of an inch of those indicated.)



# TECHNICAL SPECIFICATIONS

Hydronic Medium ESP Ducted Unit; 6R, 2 Pipe with **EC Motor**

UNIT GENERAL SPECS	PDWA-6R-[Size]-V-AECM		200	300	400	500	600	800	1000	1200	1400	1600
	Configuration		2-pipe									
	Number of Fan Blowers		Single		Twin			Three		Four	Three	Four
	Power Supply (V/Ph/Hz)		110-120/1/60					208-240/1/60				
AIR	Total Air Flow	H	224	313	421	484	596	809	957	1094	1593	2124
		M	173	284	352	360	511	591	837	1043	1524	2032
		L	133	210	186	279	430	480	686	881	1116	1488
	External Static Pressure	H	0.2									
M												
L												
COOLING	Total Cooling Capacity	H	9422	13193	17257	20261	24259	33771	39771	45272	63108	79891
		M	7777	12320	15104	16123	21619	26627	35948	43742	60949	77264
		L	6270	9744	9262	13232	19010	22568	30850	38188	48195	60816
	Sensible Cooling Capacity	H	6130	8546	11237	13143	15816	21883	25738	29244	41212	52833
		M	4985	7935	9717	10306	13937	16961	23048	28179	39743	51027
		L	3985	6192	5794	8370	12192	14295	19673	24451	30854	39467
HEATING	Heating Capacity	H	14647	20508	26827	31496	37711	52499	61826	70377	98105	124193
		M	12090	19152	23480	25063	33608	41393	55882	68000	94748	12111
		L	9747	15147	14397	20570	29551	35082	47957	59364	74922	94542
	Max. Electric Heater Capacity @ 115V	kw	1		1.5	2	2.5		3			
2			3	4	5		6					
SOUND	Pressure Level (outlet)	dB(A)	48/47/43	50/49/46	52/50/44	52/51/46	54/52/49	53/52/47	56/54/50	58/55/52	58/54/50	59/57/55
	Pressure Level (Inlet + Radiated)		50/49/45	52/51/48	54/52/46	54/53/48	56/54/51	55/54/49	58/56/52	60/57/54	60/56/52	61/59/57
	Power Level (outlet)		57/56/52	59/58/55	61/59/53	61/60/55	63/61/58	62/61/56	65/63/59	67/64/61	67/63/59	68/66/64
	Power Level (Inlet + Radiated)		59/58/54	61/60/57	63/61/55	63/62/57	65/63/60	64/63/58	67/65/61	69/66/63	69/65/61	70/68/66
ELECTRICAL	Power Input	H	53	63	83	96	102	150	180	224	363	380
		M	43	52	58	68	84	128	147	190	286	310
		L	26	31	35	49	62	84	94	113	170	190
	Running Current 115V (H)	A	0.92	1.1	1.44	1.67	1.77	2.61	3.13	3.9	6.31	6.61
Running Current 220V (H)	0.48		0.57	0.75	0.87	0.93	1.36	1.64	2.04	3.3	3.45	
HYDRONIC	Cooling Water Flow Rate	H	1.86	2.61	3.41	4	4.79	6.67	7.85	8.94	12.46	15.78
		M	1.54	2.43	2.98	3.18	4.27	5.26	7.1	8.64	12.04	15.26
		L	1.24	1.92	1.83	2.61	3.75	4.46	6.09	7.54	9.52	12.01
	Cooling Pressure Drop	H	17.35	34.53	20.15	29.09	19.71	46.52	35.59	46.99	55.25	45.06
		M	12.28	30.53	15.86	19.28	16.02	30.33	29.67	44.17	51.9	42.43
		L	8.33	20.02	6.57	13.51	12.71	22.52	22.53	34.59	34.01	27.58
	Heating Water Flow Rate	GPM	Same as cooling water flow rate									
	Heating Pressure Drop	H	15.61	31.08	18.14	26.18	17.74	41.87	32.03	42.29	49.73	40.56
M		11.05	27.48	14.27	17.36	14.42	27.29	26.7	39.76	46.71	38.19	
L		7.5	18.01	5.92	12.16	11.44	20.26	20.28	31.13	30.61	24.82	
Water Content	Gal	0.38	0.46	0.54	0.62	0.7	1.01	1.09	1.17	1.37	1.5	

**TESTING CONDITIONS (RATED AT AHRI STANDARD 440):**

- a. Cooling conditions (2-pipe or 4-pipe)**
- Return air temperature: DB 80°F/WB 67°F.
- Inlet/ outlet water temperature: 45/55°F.

- b. Heating conditions (2-pipe)**
- Return air temperature: 70°F
- Inlet water temperature: 140°F
- Water flow-rate: Same as cooling mode

(All dimensions are approximate and within 1/16 of an inch of those indicated.)

# TECHNICAL SPECIFICATIONS

Hydronic Medium ESP Ducted Unit; 3R+1 (Auxiliary Heating Coil), 4 Pipe with **EC Motor**

UNIT GENERAL SPECS		PDWA-3R+1-[Size]-P-AECM		200	300	400	500	600	800	1000	1200	1400	1600		
		Configuration		4-pipe											
		Number of Fan Blowers		Single			Twin			Three			Four	Three	Four
		Power Supply (V/Ph/Hz)		110-120/1/60 208-240/1/60											
AIR	Total Air Flow	H	CFM	259	350	479	543	662	920	1044	1188	1710	2281		
		M		205	315	403	419	567	692	909	1122	1621	2162		
		L		155	231	226	318	468	546	733	938	1182	1576		
	External Static Pressure	H	in.wg	0.2											
M															
L															
COOLING	Total Cooling Capacity	H	BTU/Hr	8471	11194	14447	16613	19222	29153	30308	34308	48115	57693		
		M		7062	10322	12667	13585	17168	23374	27190	32807	45947	55360		
		L		5650	8151	8109	10938	14794	19535	23124	28711	36082	43578		
	Sensible Cooling Capacity	H	5754	7581	9923	11318	12982	19784	20833	23549	33038	39470			
		M	4722	6957	8632	9102	11486	15595	18494	22461	31481	37748			
		L	3751	5409	5377	7279	9855	12955	15605	19411	24284	29221			
HEATING	Heating Capacity	H	BTU/Hr	7365	9705	12865	14521	17265	24485	27471	30588	41146	52457		
		M		6191	9003	11246	11925	15248	19727	24765	29316	39667	50669		
		L		4970	7065	7164	9653	13238	16439	20890	25321	31042	39624		
SOUND	Pressure Level (outlet)	dB(A)	48/47/43	48/47/43	50/49/46	52/50/44	52/51/46	54/52/49	53/52/47	56/54/50	58/55/52	58/54/50			
	Pressure Level (Inlet + Radiated)		50/49/45	50/49/45	52/51/48	54/52/46	54/53/48	56/54/51	55/54/49	58/56/52	60/57/54	60/56/52			
	Power Level (outlet)		57/56/52	59/58/55	61/59/53	61/60/55	63/61/58	62/61/56	65/63/59	67/64/61	67/63/59	68/66/64			
	Power Level (Inlet + Radiated)		59/58/54	61/60/57	63/61/55	63/62/57	65/63/60	64/63/58	67/65/61	69/66/63	69/65/61	70/68/66			
ELECTRICAL	Power Input	H	W	53	63	83	96	102	150	180	224	363	380		
		M		43	52	58	68	84	128	147	190	286	310		
		L		26	31	35	49	62	84	94	113	170	190		
	Fan Motor Running Current @ 115V / 220V	A	0.92 / 0.48	1.1 / 0.57	1.44 / 0.75	1.67 / 0.87	1.77 / 0.93	2.61 / 1.36	3.13 / 1.64	3.90 / 2.04	6.31 / 3.30	6.61 / 3.45			
HYDRONIC	Cooling Water Flow Rate	H	GPM	1.67	2.21	2.85	3.28	3.8	5.76	5.99	6.78	9.5	11.39		
		M		1.39	2.04	2.5	2.68	3.39	4.62	5.37	6.48	9.07	10.93		
		L		1.12	1.61	1.6	2.16	2.92	3.86	4.57	5.67	7.13	8.61		
	Cooling Pressure Drop	H	Ft. hd.	7.13	12.96	7.39	10.25	14.35	18.02	6.73	8.82	18.99	28.22		
		M		5.14	11.2	5.83	7.14	11.71	12.11	5.54	8.14	17.48	26.2		
		L		3.4	7.3	2.6	4.8	9	8.8	4.1	6.4	11.3	17		
	Heating Water Flow Rate	H	GPM	0.37	0.48	0.64	0.72	0.86	1.22	1.37	1.52	2.05	2.61		
		M		0.31	0.45	0.56	0.59	0.76	0.98	1.23	1.46	1.98	2.52		
		L		0.25	0.35	0.36	0.48	0.66	0.82	1.04	1.26	1.55	1.97		
	Heating Pressure Drop	H	Ft. hd.	0.74	1.37	2.54	3.49	0.74	1.86	2.43	3.16	0.48	0.81		
		M		0.54	1.2	1.99	2.45	0.59	1.26	2.02	2.93	0.45	0.76		
		L		0.36	0.77	0.88	1.67	0.46	0.91	1.48	2.25	0.29	0.49		
Chilled water content	Gal	0.19	0.19	0.19	0.23	0.27	0.31	0.35	0.51	0.55	0.59				
Hot water content		0.12	0.06	0.08	0.09	0.1	0.12	0.17	0.18	0.2	0.23				

## TESTING CONDITIONS (RATED AT AHRI STANDARD 440):

### a. Cooling conditions (2-pipe or 4-pipe)

- Return air temperature: DB 80°F/WB 67°F.
- Inlet/ outlet water temperature: 45/55°F.

### b. Heating conditions (4-pipe)

- Return air temperature: 70°F
- Inlet water temperature: 180/140°F

(All dimensions are approximate and within 1/16 of an inch of those indicated.)



# TECHNICAL SPECIFICATIONS

Hydronic Medium ESP Ducted Unit; 3R+2 (Auxiliary Heating Coil), 4Pipe with **EC Motor**

UNIT GENERAL SPECS	PDWA-3R+2-[Size]-P-AECM		200	300	400	500	600	800	1000	1200	1400	1600
	Configuration		4-pipe									
	Number of Fan Blowers		Single		Twin			Three		Four	Three	Four
	Power Supply (V/Ph/Hz)		110-120/1/60 208-240/1/60									
AIR	Total Air Flow	H	240	330	448	511	627	860	997	1138	1647	2196
		M	189	299	378	390	539	641	873	1082	1573	2097
		L	144	220	206	299	449	513	710	910	1149	1532
AIR	External Static Pressure	H	0.2									
		M										
		L										
COOLING	Total Cooling Capacity	H	7970	10718	13656	15876	18452	27523	29195	33057	46576	56054
		M	6650	9925	11970	12905	16503	22055	26487	32056	45004	54261
		L	5359	7883	7526	10511	14264	18592	22631	27921	35420	42421
	Sensible Cooling Capacity	H	5384	7245	9357	10777	12407	18631	20023	22652	31930	38252
		M	4438	6660	8106	8637	11026	14676	17984	21889	30807	36969
		L	3542	5227	4957	6967	9490	12306	15265	18839	23807	28392
HEATING	Heating Capacity	H	11215	15130	19980	22802	27497	38488	43877	49297	67673	87017
		M	9387	14107	17590	18576	24628	30809	39448	47552	65258	83468
		L	7568	11163	10882	15037	21329	25772	33494	41663	51225	66002
SOUND	Pressure Level (outlet)	dB(A)	48/47/43	50/49/46	52/50/44	52/51/46	54/52/49	53/52/47	56/54/50	58/55/52	58/54/50	59/57/55
	Pressure Level (Inlet + Radiated)		50/49/45	52/51/48	54/52/46	54/53/48	56/54/51	55/54/49	58/56/52	60/57/54	60/56/52	61/59/57
	Power Level (outlet)		57/56/52	59/58/55	61/59/53	61/60/55	63/61/58	62/61/56	65/63/59	67/64/61	67/63/59	68/66/64
	Power Level (Inlet + Radiated)		59/58/54	61/60/57	63/61/55	63/62/57	65/63/60	64/63/58	67/65/61	69/66/63	69/65/61	70/68/66
ELECTRICAL	Power Input	H	53	63	83	96	102	150	180	224	363	380
		M	43	52	58	68	84	128	147	190	286	310
		L	26	31	35	49	62	84	94	113	170	190
	Running Current 115V (H)	A	0.92	1.1	1.44	1.67	1.77	2.61	3.13	3.9	6.31	6.61
Running Current 220V (H)	0.48		0.57	0.75	0.87	0.93	1.36	1.64	2.04	3.3	3.45	
HYDRONIC	Cooling Water Flow Rate	H	1.57	2.12	2.7	3.14	3.64	5.44	5.77	6.53	9.2	11.07
		M	1.31	1.96	2.36	2.55	3.26	4.36	5.23	6.33	8.89	10.72
		L	1.06	1.56	1.49	2.08	2.82	3.67	4.47	5.51	6.99	8.38
	Cooling Pressure Drop	H	6.39	11.99	6.68	9.45	13.33	16.25	6.29	8.25	17.91	26.79
		M	4.61	10.44	5.27	6.51	10.9	10.91	5.28	7.81	16.83	25.27
		L	3.13	6.9	2.29	4.5	8.39	8.02	3.98	6.09	10.94	16.22
	Heating Water Flow Rate	H	0.56	0.75	1	1.14	1.37	1.92	2.19	2.46	3.37	4.33
		M	0.47	0.7	0.88	0.93	1.23	1.53	1.97	2.37	3.25	4.16
		L	0.38	0.56	0.54	0.75	1.06	1.25	1.67	2.08	2.55	3.29
	Heating Pressure Drop	H	0.47	0.9	1.65	0.74	1.13	2.74	1.65	2.16	1.45	2.47
		M	0.34	0.8	1.31	0.51	0.92	1.84	1.37	2.03	1.36	2.29
		L	0.23	0.52	0.55	0.35	0.71	1.33	1.02	1.6	0.88	1.5
Chilled water content	Gal	0.19	0.23	0.27	0.31	0.35	0.51	0.55	0.59	0.68	0.75	
Hot water content		0.12	0.16	0.18	0.2	0.24	0.34	0.36	0.4	0.46	0.5	

**TESTING CONDITIONS (RATED AT AHRI STANDARD 440):**

**a. Cooling conditions (2-pipe or 4-pipe)**

- Return air temperature: DB 80°F/WB 67°F.
- Inlet/ outlet water temperature: 45/55°F.

**b. Heating conditions (4-pipe)**

- Return air temperature: 70°F
- Inlet water temperature: 180/140°F

(All dimensions are approximate and within 1/16 of an inch of those indicated.)



# TECHNICAL SPECIFICATIONS

Hydronic Medium ESP Ducted Unit; 4R+2 (Auxiliary Heating Coil), 4 Pipe with **EC Motor**

UNIT GENERAL SPECS	PDWA-4R+2-[Size]-P-AECM		200	300	400	500	600	800	1000	1200	1400	1600	
	Configuration		4-pipe										
	Number of Fan Blowers		Single		Twin			Three		Four	Three	Four	
	Power Supply (V/Ph/Hz)		110-120/1/60 208-240/1/60										
AIR	Total Air Flow	H	CFM	224	313	421	484	596	809	957	1094	1593	2124
		M	CFM	173	284	352	360	511	591	837	1043	1524	2032
		L	CFM	133	210	186	279	430	480	686	881	1116	1488
	External Static Pressure	H	in.wg	0.2									
M		in.wg	0.2										
L		in.wg	0.2										
COOLING	Total Cooling Capacity	H	BTU/Hr	8497	11130	14835	18219	21136	28405	35354	40345	54732	65344
		M	BTU/Hr	6942	10378	12965	14541	18810	22396	32075	38795	52872	63519
		L	BTU/Hr	5637	8212	7882	11969	16510	18982	27406	34258	41906	50227
	Sensible Cooling Capacity	H	BTU/Hr	5617	7362	9827	15875	14020	18825	23434	26733	36725	43933
		M	BTU/Hr	4531	6812	8483	12478	12340	14590	21047	25589	35425	42601
		L	BTU/Hr	3640	5350	5016	10176	10780	12297	17865	22385	27576	33140
HEATING	Heating Capacity	H	BTU/Hr	10663	14561	19093	21888	26424	36726	42425	47988	66224	84651
		M	BTU/Hr	8806	13520	16656	17339	23475	28831	38276	46243	63809	81693
		L	BTU/Hr	7111	10637	10134	14200	20583	24413	32675	70703	50157	64694
SOUND	Pressure Level (outlet)		dB(A)	48/47/43	50/49/46	52/50/44	52/51/46	54/52/49	53/52/47	56/54/50	58/55/52	58/54/50	59/57/55
	Pressure Level (Inlet + Radiated)		dB(A)	50/49/45	52/51/48	54/52/46	54/53/48	56/54/51	55/54/49	58/56/52	60/57/54	60/56/52	61/59/57
	Power Level (outlet)		dB(A)	57/56/52	59/58/55	61/59/53	61/60/55	63/61/58	62/61/56	65/63/59	67/64/61	67/63/59	68/66/64
	Power Level (Inlet + Radiated)		dB(A)	59/58/54	61/60/57	63/61/55	63/62/57	65/63/60	64/63/58	67/65/61	69/66/63	69/65/61	70/68/66
ELECTRICAL	Power Input	H	W	53	63	83	96	102	150	180	224	363	380
		M	W	43	52	58	68	84	128	147	190	286	310
		L	W	26	31	35	49	62	84	94	113	170	190
	Running Current 115V (H)		A	0.92	1.1	1.44	1.67	1.77	2.61	3.13	3.9	6.31	6.61
Running Current 220V (H)		A	0.48	0.57	0.75	0.87	0.93	1.36	1.64	2.04	3.3	3.45	
HYDRONIC	Cooling Water Flow Rate	H	GPM	1.68	2.2	2.93	3.6	4.17	5.61	6.98	7.97	10.81	12.9
		M	GPM	1.37	2.05	2.56	2.87	3.71	4.42	6.33	7.66	10.44	12.54
		L	GPM	1.11	1.62	1.56	2.36	3.26	3.75	5.41	6.77	8.28	9.92
	Cooling Pressure Drop	H	Ft. hd.	9.57	17.05	31.26	16.08	22.67	22.83	35.49	47.51	31.42	46.86
		M	Ft. hd.	6.65	15.03	24.53	10.71	18.38	14.88	29.79	44.28	29.53	44.53
		L	Ft. hd.	4.57	9.86	10.02	7.55	14.53	11.05	22.44	35.39	19.43	29.18
	Heating Water Flow Rate	H	GPM	0.83	0.73	0.95	1.09	1.32	1.83	2.11	2.39	3.3	4.22
		M	GPM	0.37	0.6	0.7	0.75	1.06	1.37	1.55	1.91	2.39	2.79
		L	GPM	0.35	0.53	0.5	0.71	1.03	1.22	1.63	2.03	2.5	3.22
	Heating Pressure Drop	H	Ft. hd.	0.43	0.84	1.52	0.68	1.05	2.52	1.56	2.06	1.39	2.35
		M	Ft. hd.	0.3	0.74	1.19	0.45	0.85	1.63	1.29	1.93	1.3	2.2
		L	Ft. hd.	0.21	0.48	0.49	0.31	0.67	1.21	0.97	1.53	0.84	1.45
Chilled water content		Gal	0,25	0,31	0,36	0,41	0,47	0,68	0,73	0,79	0,91	1	
Hot water content		Gal	0,12	0,16	0,18	0,2	0,24	0,34	0,36	0,4	0,46	0,5	

### TESTING CONDITIONS (RATED AT AHRI STANDARD 440):

#### a. Cooling conditions (2-pipe or 4-pipe)

- Return air temperature: DB 80°F/WB 67°F.
- Inlet/ outlet water temperature: 45/55°F.

#### b. Heating conditions (4-pipe)

- Return air temperature: 70°F
- Inlet water temperature: 180/140°F

(All dimensions are approximate and within 1/16 of an inch of those indicated.)

# DIMENSIONAL DRAWINGS, DATA & WEIGHTS

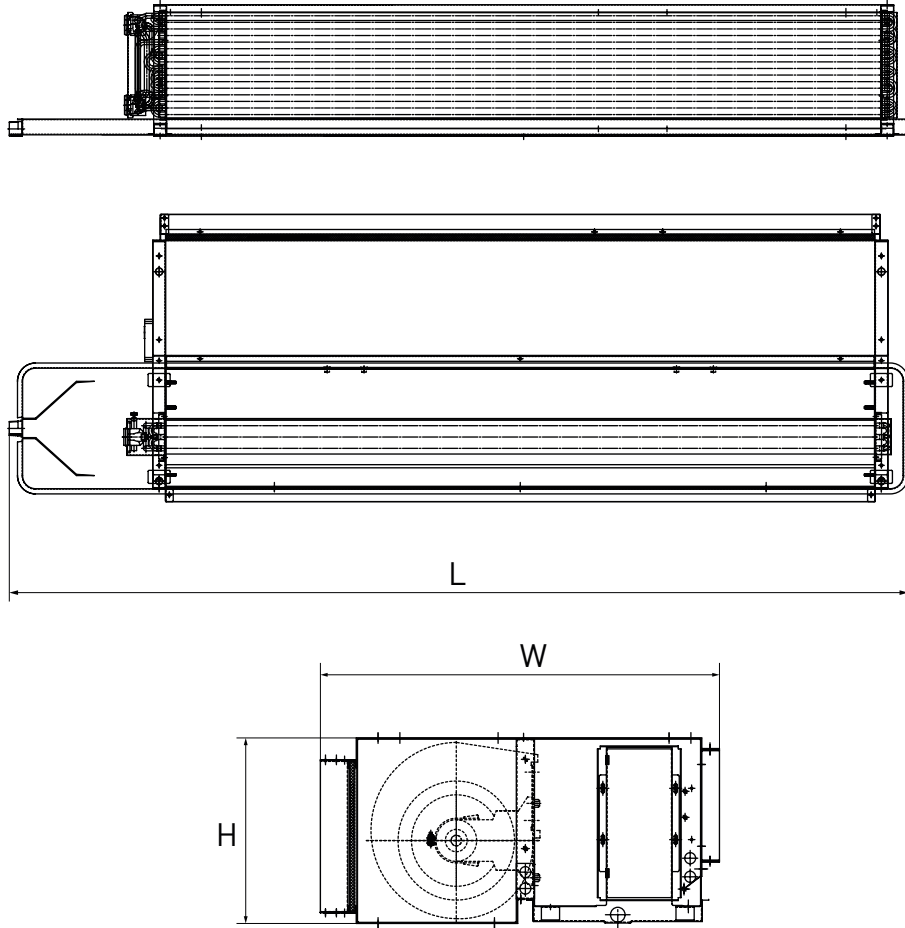

PDWA			200	300	400	500	600	800	1000	1200	1400	1600	
CONSTRUCTION AND PACKING DATA	Water Connections	Type	FNPT (Threaded Female)										
		In	3/4										
	Condensate Drainage	Out	3/4										
		Dimensions (3R, 4R and 3+1R)	L	29 3/4	33 5/8	37 5/8	45 1/2	49 3/8	65 1/8	69 1/8	73	69 1/8	77
			W	21 1/2									24 1/4
	H		9 13/16									11 13/16	
	Dimensions (6R, 3+2R and 4+2R)	L	29 3/4	33 5/8	37 5/8	45 1/2	49 3/8	65 1/8	69 1/8	73	69 1/8	77	
		W	23 1/4									26	
H		9 13/16									11 13/16		
WEIGHT	Net Weight (3R, 4R and 3+1R)	lbs	37	51	53	62	68	79	95	99	112	132	
	Net Weight (6R, 3+2R and 4+2R)	lbs	47	63	67	78	92	107	136	140	151	174	

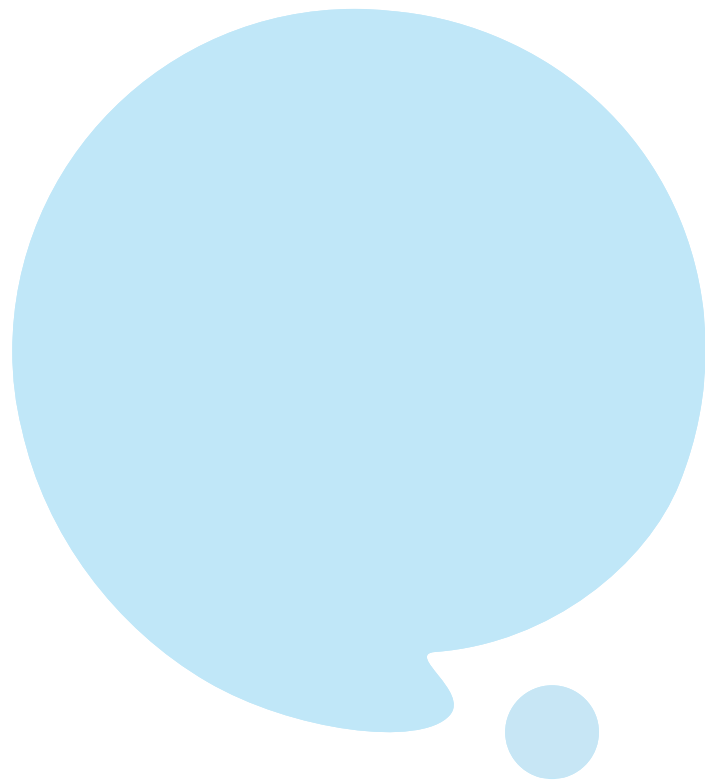

# PDWC - HIGH ESP DUCTED

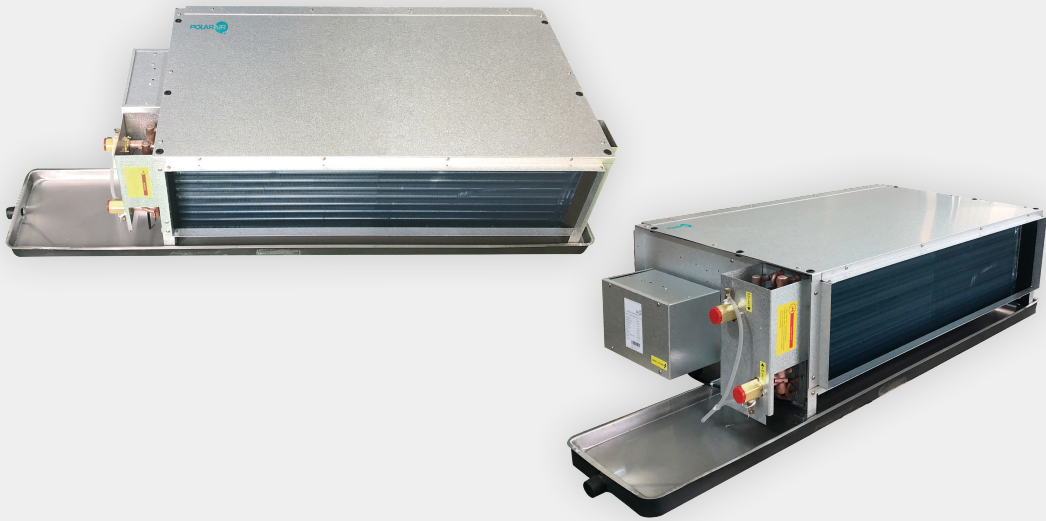

## FEATURES

### CONTROL FLEXIBILITY

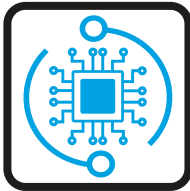

Two types of control system: Intelligent control board (I-Control) controlled via Infra-red handset and/or Intelligent wired wall pad or Flexible control (W-Control) permitting operation with external thermostat applications both controls allows configuration for 2 or 4-pipe settings.

### EFFICIENT EC MOTOR

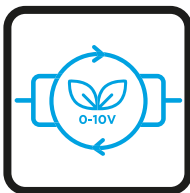

EC motors allow the centrifugal fans to operate at optimum airflow performance, energy efficiency and quiet operation. EC motors include driven control PCB, constant torque, permanent magnet and 3 speeds pre-set or modulating with a 0-10 VDC signal for precise air balancing control.

### FAN BLOWER

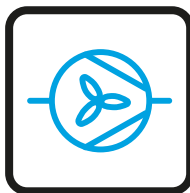

Optimized forward-curved metal centrifugal fans made from heavy-gauge galvanized steel with die-formed inlet cones housings, statically and dynamically balanced for smooth and quiet operation.

## STRUCTURE

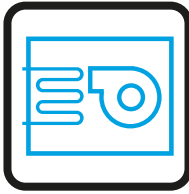

Made from heavy-gauge galvanized steel panels with couplings for the connection of ducting and gravity drain pan with insulation for condensation. Compact dimensions with optimum thermal and electrical efficiency for all types of applications.

## WATER COILS



Built with seamless copper tubes and headers, mechanically expanded into corrugated aluminium fin material for a permanent primary to secondary surface bond. Tested at 500 psi, with maximum operating limits at 300 psi.

## READY TO INSTALL



The PDWC range is offered as a complete package including standard items such as a Powder-coated steel external drain pan, NBR insulation of 0.2", and a MERV 4 filter. Furthermore, we offer multiple optional accessories.

## KEY POINTS

- Auto Dynamic Balancing with I-Control
- External Static Pressure up to 0.72 in.wg
- Coil interchangeable on field
- 3 and 4 Row configurations available



## ACCESSORIES

- IR Handset or Wired Wall Pad (Available with I-Control)
- Thermostat Controller (Available with W-Control)
- Merv 8 Filter
- Electric heater up to 9kW
- Additional NBR Insulation up to 1"
- Stainless Steel Drain Pan
- 2 or 3 Way On/Off & Modulating Valves
- Belimo Valve Kit
- Integrated Sauermann Condensate Pump
- Supply/Return air Plenum

\*Please refer to page 86 for further information and accessories.



# TECHNICAL SPECIFICATIONS

Hydronic High ESP Ducted Unit; 3R, 2 Pipe with **EC Motor**

UNIT GENERAL SPECS			PDWC-3R-[Size]-V-AECM	400	500	600	800	1000	1400	1600	2000		
			Configuration		2-pipe								
			Number of Fan Blowers		Single			Twin			Three		Four
			Power Supply (V/Ph/Hz)		110-120/1/60 208-240/1/60								
AIR	Total Air Flow	H	CFM	435	523	1055	1221	1437	1646	1810	2783		
		M	CFM	344	421	906	1151	1239	1463	1598	2437		
		L	CFM	232	236	390	436	480	735	970	1303		
AIR	External Static Pressure	H	in.wg	0.2									
		M	in.wg	0.2									
		L	in.wg	0.2									
COOLING	Total Cooling Capacity	H	BTU/Hr	12539	15369	28557	33226	38900	45385	49757	69738		
		M	BTU/Hr	10551	12989	25373	31749	34794	41525	45140	63110		
		L	BTU/Hr	7753	8221	13284	15075	16575	24480	30766	39137		
	Sensible Cooling Capacity	H	BTU/Hr	8530	10349	19564	22712	26400	30842	33908	48511		
		M	BTU/Hr	7077	8636	17274	21680	23433	28062	30546	43687		
		L	BTU/Hr	5131	5335	8700	9808	10807	15976	20396	26337		
HEATING	Heating Capacity	H	BTU/Hr	19493	23892	44393	51651	60472	70553	77349	108410		
		M	BTU/Hr	16403	20192	39443	49356	54089	64553	70172	98107		
		L	BTU/Hr	12053	12780	20650	23434	25767	38055	47828	60840		
	Max. Electric Heater Capacity @ 115V Max. Electric Heater Capacity @ 220V	kW		19493	23892	44393	51651	60472	70553	77349	108410		
		kW		16403	20192	39443	49356	54089	64553	70172	98107		
SOUND	Pressure Level (outlet)	dB(A)		54/50/45	56/53/43	56/54/47	58/56/47	56/52/45	59/57/47	60/58/56	64/62/52		
	Pressure Level (Inlet + Radiated)	dB(A)		57/53/48	59/56/46	59/57/50	61/59/50	59/55/48	62/60/50	63/61/59	67/65/55		
	Power Level (outlet)	dB(A)		63/59/54	65/62/52	65/63/56	67/65/56	65/61/54	68/66/56	69/67/59	73/71/61		
	Power Level (Inlet + Radiated)	dB(A)		66/62/57	68/65/55	68/66/59	70/68/59	68/64/57	71/69/59	72/70/62	76/74/64		
ELECTRICAL	Power Input	H	W	152	202	195	281	310	413	477	637		
		M	W	84	121	137	208	151	246	304	461		
		L	W	32	34	62	65	70	72	108	142		
	Running Current 115V (H)	A		2.64	3.51	3.39	4.89	5.39	7.18	8.3	11.07		
	Running Current 220V (H)	A		1.38	1.84	1.77	2.55	2.82	3.75	4.34	5.79		
HYDRONIC	Cooling Water Flow Rate	H	GPM	2.48	3.04	5.64	6.56	7.68	8.96	9.83	13.77		
		M	GPM	2.08	2.56	5.01	6.27	6.87	8.2	8.91	12.46		
		L	GPM	1.53	1.62	2.62	2.98	3.27	4.83	6.08	7.73		
	Cooling Pressure Drop	H	Ft. hd.	6.01	9.38	16.5	41.42	11.78	17.49	11.57	12.59		
		M	Ft. hd.	4.4	6.93	13.34	38.17	9.64	14.91	9.71	10.51		
		L	Ft. hd.	2.53	3.04	4.16	9.99	2.54	5.76	4.87	4.45		
	Heating Water Flow Rate	GPM		Same as cooling water flow rate									
		GPM		Same as cooling water flow rate									
		GPM		Same as cooling water flow rate									
	Heating Pressure Drop	H	ft.wg.	5.41	8.44	14.85	37.28	10.61	15.74	10.41	11.33		
		M	ft.wg.	3.96	6.23	12	34.35	8.68	13.42	8.74	9.46		
L		ft.wg.	2.28	2.74	3.74	8.99	2.28	5.18	4.38	4			
Water Content	Gal		0.29	0.29	0.34	0.49	0.46	0.64	0.76	0.88			

**TESTING CONDITIONS (RATED AT AHRI STANDARD 440):**

**a. Cooling mode:**

- Return air temperature: 80 °F DB/ 67 °F WB.
- Inlet/ outlet water temperature: 45/55°F.

**b. Heating mode:**

- Return air temperature: 70°F.
- Inlet water temperature: 140 °F.
- Same water flow as cooling mode.

# TECHNICAL SPECIFICATIONS

Hydronic High ESP Ducted Unit; 4R, 2 Pipe with **EC Motor**

UNIT GENERAL SPECS	PDWC-4R-[Size]-V-AECM		400	500	600	800	1000	1400	1600	2000	
	Configuration		2-pipe								
	Number of Fan Blowers		Single		Twin			Three		Four	
	Power Supply (V/Ph/Hz)		110-120/1/60				208-240/1/60				
AIR	Total Air Flow	H	413	504	996	1164	1382	1604	1776	2688	
		M	315	397	847	1087	1167	1402	1539	2332	
		L	177	205	333	382	416	634	886	1138	
External Static Pressure	in.wg	H	0.2								
		M	0.2								
		L	0.2								
COOLING	Total Cooling Capacity	H	15582	19185	34535	40769	47826	55237	62819	89896	
		M	12643	16004	30534	38725	42148	50131	56293	81075	
		L	8043	9473	14889	17260	19039	27294	36520	46789	
	Sensible Cooling Capacity	H	10282	12609	23107	27196	31998	36967	41778	60288	
		M	8205	12036	20295	25756	27994	33370	37254	54006	
		L	5091	5974	9446	10936	12077	17450	23594	30180	
HEATING	Heating Capacity	H	24223	29824	53687	63377	74348	85868	97655	139747	
		M	19655	24879	47466	60200	65521	77931	87510	126035	
		L	12503	14726	23145	26832	29598	42429	56772	72735	
	Max. Electric Heater Capacity @ 115V	kW	1.5				3			4.5	
			3				6			9	
SOUND	Pressure Level (outlet)		54/50/45	56/53/43	56/54/47	58/56/47	56/52/45	59/57/47	60/58/56	64/62/52	
	Pressure Level (Inlet + Radiated)		57/53/48	59/56/46	59/57/50	61/59/50	59/55/48	62/60/50	63/61/59	67/65/55	
	Power Level (outlet)		63/59/54	65/62/52	65/63/56	67/65/56	65/61/54	68/66/56	69/67/59	73/71/61	
	Power Level (Inlet + Radiated)		66/62/57	68/65/55	68/66/59	70/68/59	68/64/57	71/69/59	72/70/62	76/74/64	
ELECTRICAL	Power Input	H	152	202	195	281	310	413	477	637	
		M	84	121	137	208	151	246	304	461	
		L	32	34	62	65	70	72	108	142	
	Running Current 115V (H)		A	2.64	3.51	3.39	4.89	5.39	7.18	8.3	11.07
	Running Current 220V (H)			1.38	1.84	1.77	2.55	2.82	3.75	4.34	5.79
HYDRONIC	Cooling Water Flow Rate	H	3.08	3.79	6.82	8.05	9.44	10.91	12.41	17.75	
		M	2.5	3.16	6.03	7.65	8.32	9.9	11.12	16.01	
		L	1.59	1.87	2.94	3.41	3.76	5.39	7.21	9.24	
	Cooling Pressure Drop	H	13.01	55.98	67.21	39.03	69.2	33.33	46.47	97.26	
		M	8.93	40.39	53.85	35.58	55.12	27.99	38.14	80.76	
		L	3.96	15.72	14.78	8.31	13.19	9.37	17.5	30.02	
	Heating Water Flow Rate	H	Same as cooling water flow rate								
		M	Same as cooling water flow rate								
		L	Same as cooling water flow rate								
	Heating Pressure Drop	H	11.71	50.38	60.49	35.13	62.28	30	41.82	87.53	
M		8.04	36.35	48.46	32.02	49.61	25.19	34.33	72.68		
L		3.56	14.15	13.3	7.48	11.87	8.43	15.75	27.02		
Water Content		Gal	0.38	0.45	0.65	0.62	0.86	1.01	1.17	1.33	

## TESTING CONDITIONS (RATED AT AHRI STANDARD 440):

### a. Cooling mode:

- Return air temperature: 80 °F DB/ 67 °F WB.
- Inlet/ outlet water temperature: 45/55°F.

### b. Heating mode:

- Return air temperature: 70°F.
- Inlet water temperature: 140 °F.
- Same water flow as cooling mode.



# TECHNICAL SPECIFICATIONS

Hydronic High ESP Ducted Unit; 3R+1 (Auxiliary Heating Coil); 4 pipe, with **EC Motor**

UNIT GENERAL SPECS			PDWC-3R+1-[Size]-P-AECM	400	500	600	800	1000	1400	1600	2000		
			Configuration		4-pipe								
			Number of Fan Blowers		Single			Twin				Four	
			Power Supply (V/Ph/Hz)		110-120/1/60 208-240/1/60								
AIR	Total Air Flow	H	CFM	413	504	996	1164	1382	1604	1776	2688		
		M	CFM	315	397	847	1087	1167	1402	1539	2332		
		L	CFM	177	205	333	382	416	634	886	1138		
AIR	External Static Pressure	H	in.wg	0.2									
		M	in.wg	0.2									
		L	in.wg	0.2									
COOLING	Total Cooling Capacity	H	BTU/Hr	12092	15009	27288	32119	37805	44420	49046	67955		
		M	BTU/Hr	9887	12458	24245	30508	33137	40239	43719	61327		
		L	BTU/Hr	6246	7432	11791	13598	14665	21634	28711	34984		
	Sensible Cooling Capacity	H	BTU/Hr	8213	10078	18627	21938	25625	30157	33403	47171		
		M	BTU/Hr	6604	8276	16442	20777	22198	27093	29472	42347		
		L	BTU/Hr	4072	4831	7644	8822	9664	14070	18896	23425		
HEATING	Heating Capacity	H	BTU/Hr	11703	14189	25735	30537	35535	40875	45895	64677		
		M	BTU/Hr	9569	11777	22734	29010	31066	37027	41270	58082		
		L	BTU/Hr	6045	7026	11087	12993	13911	19907	26643	33463		
SOUND	Pressure Level (outlet)	dB(A)		54/50/45	56/53/43	56/54/47	58/56/47	56/52/45	59/57/47	60/58/56	64/62/52		
	Pressure Level (Inlet + Radiated)	dB(A)		57/53/48	59/56/46	59/57/50	61/59/50	59/55/48	62/60/50	63/61/59	67/65/55		
	Power Level (outlet)	dB(A)		63/59/54	65/62/52	65/63/56	67/65/56	65/61/54	68/66/56	69/67/59	73/71/61		
	Power Level (Inlet + Radiated)	dB(A)		66/62/57	68/65/55	68/66/59	70/68/59	68/64/57	71/69/59	72/70/62	76/74/64		
ELECTRICAL	Power Input	H	W	152	202	195	281	310	413	477	637		
		M	W	84	121	137	208	151	246	304	461		
		L	W	32	34	62	65	70	72	108	142		
	Running Current 115V (H)	A		2.64	3.51	3.39	4.89	5.39	7.18	8.3	11.07		
Running Current 220V (H)	A		1.38	1.84	1.77	2.55	2.82	3.75	4.34	5.79			
HYDRONIC	Cooling Water Flow Rate	H	GPM	2.39	2.96	5.39	6.34	7.47	8.77	9.69	13.42		
		M	GPM	1.95	2.46	4.49	6.02	6.54	7.95	8.63	12.11		
		L	GPM	1.23	1.47	2.33	2.69	2.9	4.27	5.67	6.91		
	Cooling Pressure Drop	H	Ft. hd.	5.63	8.99	15.2	38.97	11.19	16.83	11.27	12.01		
		M	Ft. hd.	3.92	6.43	12.29	35.53	8.83	14.09	9.17	9.99		
		L	Ft. hd.	1.71	2.54	3.36	8.3	2.04	4.61	4.3	3.64		
	Heating Water Flow Rate	H	GPM	0.6	0.7	1.3	1.5	1.8	2	2.3	3.2		
		M	GPM	0.5	0.6	1.1	1.5	1.6	1.8	2.1	2.9		
		L	GPM	0.3	0.35	0.55	0.65	0.7	1	1.3	1.7		
	Heating Pressure Drop	H	ft.wg.	2.4	3.9	2.1	3.5	4.9	2.3	3.2	6.6		
		M	ft.wg.	1.7	2.8	1.7	3.2	3.8	1.9	2.6	5.4		
		L	ft.wg.	0.7	1.1	0.5	0.8	0.9	0.6	1.2	2		
Chilled water content		Gal		0,29	0,34	0,49	0,46	0,64	0,76	0,88	1		
Hot water content		Gal		0,1	0,11	0,16	0,15	0,21	0,25	0,29	0,33		

**TESTING CONDITIONS (RATED AT AHRI STANDARD 440):**

**a. Cooling mode:**

- Return air temperature: 80 °F DB/ 67 °F WB.
- Inlet/ outlet water temperature: 45/55°F.

**b. Heating mode:**

- Return air temperature: 70°F.
- Inlet water temperature: 140 °F/120°F.



# TECHNICAL SPECIFICATIONS

Hydronic High ESP Ducted Unit; 4R+1 (Auxiliary Heating Coil); 4 pipe, with **EC Motor**

UNIT GENERAL SPECS	PDWC-4R+1-[Size]-P-AECM		400	500	600	800	1000	1400	1600	2000
	Configuration		4-pipe							
	Number of Fan Blowers		Single			Twin				Four
	Power Supply (V/Ph/Hz)		110-120/1/60 208-240/1/60							
AIR	Total Air Flow	H	394	489	947	1116	1337	1569	1748	2608
		M	299	382	813	1049	1106	1351	1490	2244
		L	152	193	309	360	379	576	837	1042
AIR	External Static Pressure	H	0.2							
		M								
		L								
COOLING	Total Cooling Capacity	H	15026	18746	33178	39389	46733	54606	62041	87880
		M	12163	15519	29686	37840	40417	48720	54651	78856
		L	7200	9065	13950	16323	17467	25066	35094	43578
	Sensible Cooling Capacity	H	9899	12288	22129	26236	31250	36508	41228	58844
		M	7879	10041	19683	25116	26796	32390	36119	52466
		L	4543	5736	8825	10325	11132	15989	22583	27894
HEATING	Heating Capacity	H	11357	13849	24732	29689	34594	40283	45545	63358
		M	9186	11401	22098	28272	29891	35828	40165	56324
		L	5366	6551	10485	12275	12927	18334	25758	31240
SOUND	Pressure Level (outlet)	dB(A)	54/50/45	56/53/43	56/54/47	58/56/47	56/52/45	59/57/47	60/58/56	64/62/52
	Pressure Level (Inlet + Radiated)		57/53/48	59/56/46	59/57/50	61/59/50	59/55/48	62/60/50	63/61/59	67/65/55
	Power Level (outlet)		63/59/54	65/62/52	65/63/56	67/65/56	65/61/54	68/66/56	69/67/59	73/71/61
	Power Level (Inlet + Radiated)		66/62/57	68/65/55	68/66/59	70/68/59	68/64/57	71/69/59	72/70/62	76/74/64
ELECTRICAL	Power Input	H	152	202	195	281	310	413	477	637
		M	84	121	137	208	151	246	304	461
		L	32	34	62	65	70	72	108	142
	Running Current 115V (H)	A	2.64	3.51	3.39	4.89	5.39	7.18	8.3	11.07
Running Current 220V (H)	1.38		1.84	1.77	2.55	2.82	3.75	4.34	5.79	
HYDRONIC	Cooling Water Flow Rate	H	2.97	3.7	6.55	7.78	9.23	10.78	12.25	17.35
		M	2.4	3.06	5.86	7.47	7.98	9.62	10.79	15.57
		L	1.42	1.79	2.75	3.22	3.45	4.95	6.93	8.61
	Cooling Pressure Drop	H	12.18	53.69	62.53	36.69	66.38	32.65	45.44	93.37
		M	8.33	38.22	51.19	34.13	51.12	26.59	36.16	76.82
		L	3.24	14.52	13.15	7.51	11.29	8.04	16.29	26.42
	Heating Water Flow Rate	H	0.57	0.69	1.23	1.48	1.72	2.01	2.27	3.16
		M	0.46	0.57	1.1	1.41	1.49	1.78	2	2.81
		L	0.27	0.33	0.52	0.61	0.64	0.91	1.28	1.56
	Heating Pressure Drop	H	2.3	3.69	1.93	3.31	4.63	2.22	3.13	6.34
		M	1.57	2.6	1.58	3.04	3.56	1.8	2.5	5.13
		L	0.6	0.96	0.41	0.68	0.79	0.54	1.12	1.78
Chilled water content		Gal	0.29	0.34	0.49	0.46	0.64	0.76	0.88	1
Hot water content			0.1	0.11	0.16	0.15	0.21	0.25	0.29	0.33

## TESTING CONDITIONS (RATED AT AHRI STANDARD 440):

### a. Cooling mode:

- Return air temperature: 80 °F DB/ 67 °F WB.
- Inlet/ outlet water temperature: 45/55°F.

### b. Heating mode:

- Return air temperature: 70°F.
- Inlet water temperature: 140 °F/120°F

# DIMENSIONAL DRAWINGS, DATA & WEIGHTS

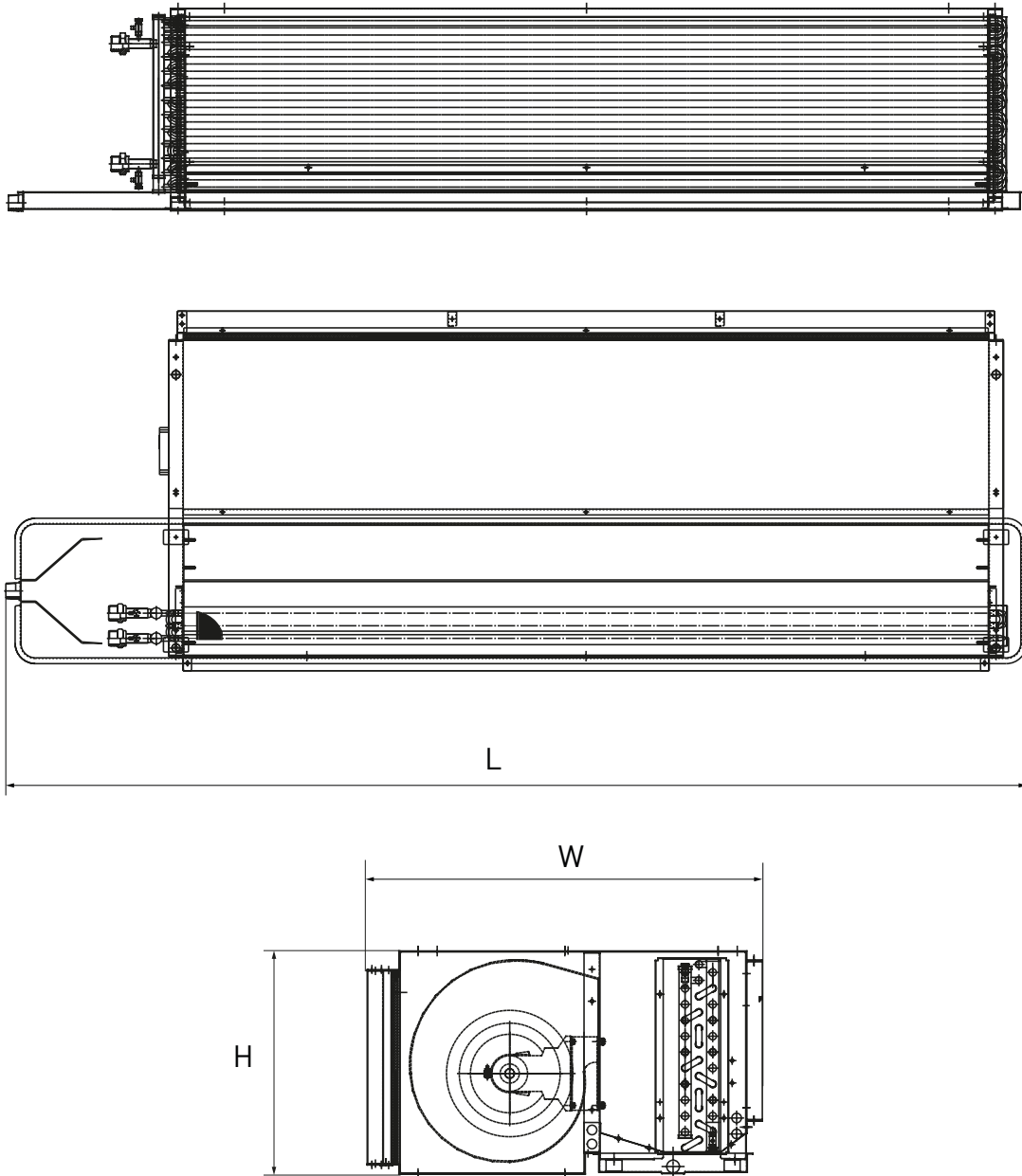

PDWC			400	500	600	800	1000	1400	1600	2000
CONSTRUCTION AND PACKING DATA	Water Connections	Type	FNPT (Threaded Female)							
		In Out	3/4							
	Condensate Drainage	L	41 1/2	45 1/2	53 3/8	53 3/8	57 1/4	65 1/8	73	87 1/4
		W	24 3/8							
H		11 3/4				13 3/4				
WEIGHT	Net Weight	lbs	62	82	97	101	106	121	139	183

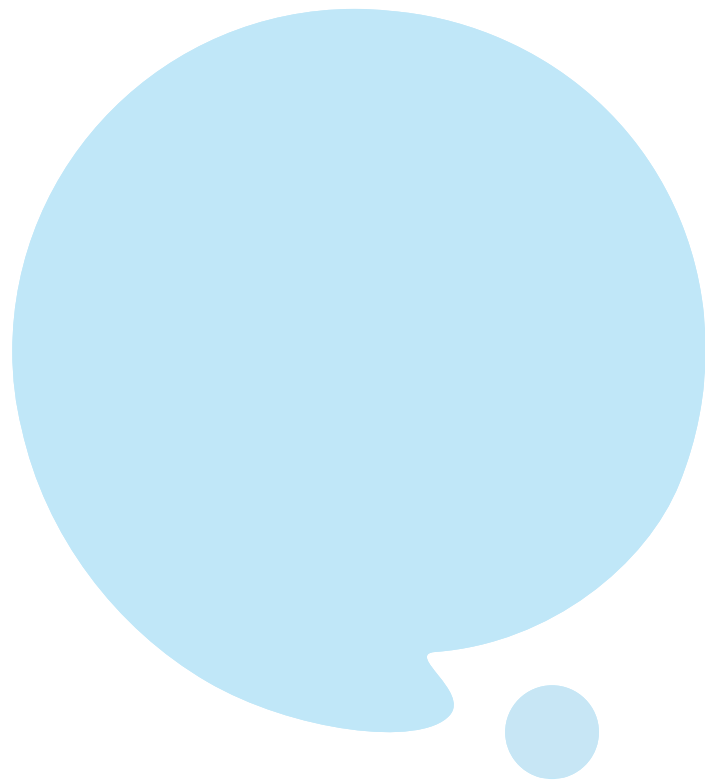

## PDWD - DOUBLE SKIN HIGH ESP DUCTED



### FEATURES

---

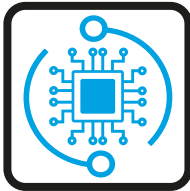

#### CONTROL FLEXIBILITY

Two types of control system: Intelligent control board (I-Control) controlled via Infra-red handset and/or Intelligent wired wall pad or Flexible control (W-Control) permitting operation with external thermostat applications both controls allows configuration for 2 or 4-pipe settings.

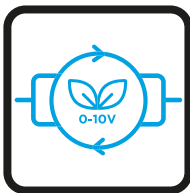

#### EFFICIENT EC MOTOR

EC motors allow the centrifugal fans to operate at optimum airflow performance, energy efficiency and quiet operation. EC motors include driven control PCB, constant torque, permanent magnet and 3 speeds pre-set or modulating with a 0-10 VDC signal for precise air balancing control.



#### FAN BLOWER

Optimized forward-curved metal centrifugal fans made from heavy-gauge galvanized steel with die-formed inlet cones housings, statically and dynamically balanced for smooth and quiet operation.

## STRUCTURE

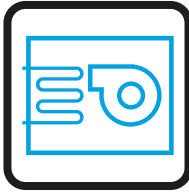

Casing is double skin with inner wall and outer wall coated steel panels in RAL 9010 colour with high pressure PU foam insulation sandwiched in between. It has couplings for the connection of ducting and gravity drain pan with insulation for condensation. The unit has an easy access to fans, motors and filters.

## WATER COILS



Built with seamless copper tubes and headers, mechanically expanded into corrugated aluminium fin material for a permanent primary to secondary surface bond. Tested at 500 psi, with maximum operating limits at 300 psi.

## READY TO INSTALL



The PDWD double-skin range is offered as a complete package including standard items such as a powder-coated steel internal drain pan, double sandwich panel insulation of 0.6" + 1", and a MERV 4 filter. Furthermore, we offer multiple optional accessories.

## KEY POINTS

- Auto Dynamic Balancing with I-Control
- External Static Pressure up to 0.8 in.wg
- Formidable insulation
- 3, 4 and 6 Rows configurations available



## ACCESSORIES

- IR Handset or Wired Wall Pad (Available with I-Control)
- Thermostat Controller (Available with W-Control)
- Merv 8 Filter
- Electric heater up to 9kW
- Stainless Steel Drain Pan
- 2 or 3 Way On/Off & Modulating Valves
- Belimo Valve Kit
- Supply/Return air Plenum

\*Please refer to page 86 for further information and accessories.



# TECHNICAL SPECIFICATIONS

Hydronic Double Skin Ducted unit, 3R, 2 pipe, with EC Motor **EC Motor**

UNIT GENERAL SPECS	PDWD-3R-[Size]-V-AECM		400	800	1200	1600	2000
	Configuration		2-pipe				
	Number of Fan Blowers		Single	Twin			Four
	Power Supply (V/Ph/Hz)		208-240 / 1 / 60				
AIR	Total Air Flow	H	527	1221	1646	1810	3620
		M	428	1151	1463	1598	3196
		L	236	436	735	970	1941
	External Static Pressure	H	0.2				
		M					
		L					
COOLING	Total Cooling Capacity	H	15322	32133	42715	48451	86865
		M	13029	30705	39089	44064	78900
		L	8212	14579	22871	29850	54182
	Sensible Cooling Capacity	H	10386	22108	29376	33070	60652
		M	8759	21103	26740	29773	54841
		L	5363	9547	15159	19751	36744
HEATING	Heating Capacity	H	23819	49952	66402	75320	135036
		M	20255	47732	60765	68500	122653
		L	12766	22664	35554	46403	84229
	Max. Electric Heater Capacity @ 115V	kw	3	3	3	6	9
SOUND	Pressure Level (Outlet)	dB(A)	56/53/43	58/56/47	56/52/45	60/58/50	65/63/60
	Pressure Level (Inlet + Radiated)		59/56/46	61/59/50	57/55/48	63/61/53	65/63/60
	Power Level (Outlet)		65/62/52	67/65/56	65/61/54	69/67/59	74/72/69
	Power Level (Inlet + Radiated)		68/65/55	70/68/59	68/64/57	72/70/62	74/72/69
ELECTRICAL	Power Input	H	202	281	310	477	672
		M	121	208	151	304	546
		L	34	65	70	108	280
	Running Current 220V (H)	A	1.83	2.55	2.81	4.33	6.1
HYDRONIC	Cooling Water Flow Rate	H	3.03	6.35	8.44	9.57	17.15
		M	2.57	6.06	7.72	8.7	15.58
		L	1.62	2.88	4.52	5.89	10.7
	Cooling Pressure Drop	H	10.28	13.31	15.3	10.43	19.21
		M	7.68	12.27	13.04	8.79	16.15
		L	3.35	3.21	4.97	4.36	8.21
	Heating Water Flow Rate	H	Same as cooling water flow rate				
		M					
		L					
	Heating Pressure Drop	H	9.25	11.98	13.77	9.39	17.29
M		6.91	11.04	11.74	7.91	14.54	
L		3.01	2.89	4.47	3.92	7.39	
Water Content	Gal	0.33	0.47	0.62	0.86	0.97	

**TESTING CONDITIONS (RATED AT AHRI STANDARD 440):**

**a. Cooling mode (2-pipe/ 4-pipe):**

- Return air temperature: DB 80°F/WB 67°F
- Inlet/ outlet water temperature: 45°F/ 55°F

**b. Heating mode (2-pipe):**

- Return air temperature: 70°F
- Inlet water temperature: 140°F
- Water flow-rate: Same as cooling mode

# TECHNICAL SPECIFICATIONS

Hydronic Double Skin Ducted unit, 4R, 2 pipe, with **EC Motor**

UNIT GENERAL SPECS	PDWD-4R-[Size]-V-AECM		400	800	1200	1600	2000
	Configuration		2-pipe				
	Number of Fan Blowers		Single	Twin			Four
	Power Supply (V/Ph/Hz)		208-240 / 1 / 60				
AIR	Total Air Flow	H	509	1164	1604	1776	3552
		M	403	1087	1402	1539	3078
		L	205	382	634	886	1772
	External Static Pressure	H	0.2				
		M					
		L					
COOLING	Total Cooling Capacity	H	18094	37710	52013	59198	107449
		M	15181	35819	46742	53233	96623
		L	8829	15965	25575	34366	63300
	Sensible Cooling Capacity	H	11939	25307	34728	39200	72612
		M	9902	23968	31044	34875	64792
		L	5363	9547	15159	19751	36744
HEATING	Heating Capacity	H	28127	58621	80856	92026	167035
		M	23600	55683	72663	82753	150205
		L	13880	24818	39757	53423	98402
	Max. Electric Heater Capacity @ 115V	kw	3	3	3	6	9
SOUND	Pressure Level (Outlet)	dB(A)	56/53/43	58/56/47	56/52/45	60/58/50	65/63/60
	Pressure Level (Inlet + Radiated)		59/56/46	61/59/50	57/55/48	63/61/53	65/63/60
	Power Level (Outlet)		65/62/52	67/65/56	65/61/54	69/67/59	74/72/69
	Power Level (Inlet + Radiated)		68/65/55	70/68/59	68/64/57	72/70/62	74/72/69
ELECTRICAL	Power Input	H	202	281	310	477	672
		M	121	208	151	304	546
		L	34	65	70	108	280
	Running Current 220V (H)	A	1.83	2.55	2.81	4.33	6.1
HYDRONIC	Cooling Water Flow Rate	H	3.57	7.45	10.27	11.69	21.22
		M	3	7.07	9.23	10.51	19.08
		L	1.76	3.15	5.05	6.79	12.5
	Cooling Pressure Drop	H	55.56	43.02	87.09	43.09	150.54
		M	40.51	39.21	71.85	35.59	124.35
		L	15.58	9.16	24.27	16.19	58.08
	Heating Water Flow Rate	H	Same as cooling water flow rate				
		M					
		L					
	Heating Pressure Drop	H	50	38.72	78.38	38.78	135.49
M		36.46	35.29	64.67	32.03	111.91	
L		14.02	8.24	21.84	14.57	52.27	
Water Content	Gal	0.44	0.63	0.83	1.14	1.29	

## TESTING CONDITIONS (RATED AT AHRI STANDARD 440):

### a. Cooling mode (2-pipe/ 4-pipe):

- Return air temperature: DB 80°F/WB
- Inlet/ outlet water temperature: 45°F/ 55°F

### b. Heating mode (2-pipe):

- Return air temperature: 70°F
- Inlet water temperature: 140°F
- Water flow-rate: Same as cooling mode

# TECHNICAL SPECIFICATIONS

Hydronic Double Skin Ducted unit, 6R, 2 pipe, with **EC Motor**

UNIT GENERAL SPECS	PDWD-6R-[Size]-V-AECM		400	800	1200	1600	2000
	Configuration		2-pipe				
	Number of Fan Blowers		Single	Twin			Four
	Power Supply (V/Ph/Hz)		208-240 / 1 / 60				
AIR	Total Air Flow	H	479	1069	1534	1720	3440
		M	374	1012	1330	1470	2940
		L	180	338	551	815	1631
	External Static Pressure	H	0.2				
		M					
		L					
COOLING	Total Cooling Capacity	H	19728	41770	58967	69387	125505
		M	16367	39966	52681	61576	111071
		L	9163	17093	26422	39170	71197
	Sensible Cooling Capacity	H	12848	27455	38897	45240	83242
		M	10502	26200	34582	39724	73166
		L	5705	10707	16638	24651	45593
HEATING	Heating Capacity	H	30668	64933	91667	107866	195103
		M	25443	62129	81896	95723	172665
		L	14244	26571	41075	60892	110678
	Max. Electric Heater Capacity @ 115V	kw	3	3	3	6	9
SOUND	Pressure Level (Outlet)	dB(A)	56/53/43	58/56/47	56/52/45	60/58/50	65/63/60
	Pressure Level (Inlet + Radiated)		59/56/46	61/59/50	57/55/48	63/61/53	65/63/60
	Power Level (Outlet)		65/62/52	67/65/56	65/61/54	69/67/59	74/72/69
	Power Level (Inlet + Radiated)		68/65/55	70/68/59	68/64/57	72/70/62	74/72/69
ELECTRICAL	Power Input	H	202	281	310	477	672
		M	121	208	151	304	546
		L	34	65	70	108	280
	Running Current 220V (H)	A	1.83	2.55	2.81	4.33	6.1
HYDRONIC	Cooling Water Flow Rate	H	3.9	8.25	11.64	13.7	24.78
		M	3.23	7.89	10.4	12.16	21.93
		L	1.81	3.38	5.22	7.74	14.06
	Cooling Pressure Drop	H	14.52	25.35	24.49	38.72	134.46
		M	10.37	23.41	19.99	31.23	107.92
		L	3.65	5.08	5.77	13.83	48.47
	Heating Water Flow Rate	H	Same as cooling water flow rate				
		M					
		L					
	Heating Pressure Drop	H	13.07	22.81	22.04	34.85	121.02
M		9.34	21.07	17.99	28.11	97.13	
L		3.29	4.57	5.2	12.45	43.62	
Water Content	Gal	0.44	0.63	0.83	1.14	1.29	

**TESTING CONDITIONS (RATED AT AHRI STANDARD 440):**

**a. Cooling mode (2-pipe/ 4-pipe):**

- Return air temperature: DB 80°F/WB 67°F
- Inlet/ outlet water temperature: 45°F/ 55°F

**b. Heating mode (2-pipe):**

- Return air temperature: 70°F
- Inlet water temperature: 140°F
- Water flow-rate: Same as cooling mode



# TECHNICAL SPECIFICATIONS

Hydronic Double Skin Ducted Unit; 3R+1 (Auxiliary Heating Coil); 4 pipe, with **EC Motor**

UNIT GENERAL SPECS	PDWD-3R+1-[Size]-P-AECM		400	800	1200	1600	2000	
	Configuration		4-pipe					
	Number of Fan Blowers		Single	Twin			Four	
	Power Supply (V/Ph/Hz)		208-240 / 1 / 60					
AIR	Total Air Flow	H	509	1164	1604	1776	3552	
		M	403	1087	1402	1539	3078	
		L	205	382	634	886	1772	
	External Static Pressure	H	0.2					
		M						
		L						
COOLING	Total Cooling Capacity	H	14932	31062	41987	47723	85421	
		M	12529	29505	37732	42915	76814	
		L	7369	13151	20645	27705	50322	
	Sensible Cooling Capacity	H	10108	21354	28832	32534	59743	
		M	8384	20224	25773	28945	53309	
		L	4775	8587	13551	18208	33967	
HEATING	Heating Capacity	H	14309	29495	39582	44924	80862	
		M	12006	28017	35571	40397	72715	
		L	7061	12487	19462	26079	47637	
SOUND	Pressure Level (Outlet)		56/53/43	58/56/47	56/52/45	60/58/50	65/63/60	
	Pressure Level (Inlet + Radiated)		59/56/46	61/59/50	57/55/48	63/61/53	65/63/60	
	Power Level (Outlet)		65/62/52	67/65/56	65/61/54	69/67/59	74/72/69	
	Power Level (Inlet + Radiated)		68/65/55	70/68/59	68/64/57	72/70/62	74/72/69	
ELECTRICAL	Power Input	H	202	281	310	477	672	
		M	121	208	151	304	546	
		L	34	65	70	108	280	
	Running Current 220V (H)		A	1.83	2.55	2.81	4.33	6.1
HYDRONIC	Cooling Water Flow Rate	H	2.95	6.13	8.29	9.42	16.87	
		M	2.47	5.83	7.45	8.47	15.17	
		L	1.46	2.6	4.08	5.47	9.94	
	Cooling Pressure Drop	H	9.82	12.52	14.84	10.15	18.64	
		M	7.16	11.42	12.24	8.38	15.39	
		L	2.75	2.67	4.13	3.81	7.19	
	Heating Water Flow Rate	H	0.71	1.47	1.97	2.24	4.03	
		M	0.6	1.4	1.77	2.01	3.62	
		L	0.35	0.62	0.97	1.3	2.37	
	Heating Pressure Drop	H	3.87	2.96	5.88	2.86	10.11	
		M	2.82	2.7	4.85	2.36	8.35	
		L	1.09	0.63	1.64	1.08	3.9	
	Chilled water content		Gal	0.33	0.47	0.62	0.86	0.97
	Hot water content			0.11	0.16	0.21	0.29	0.32

## TESTING CONDITIONS (RATED AT AHRI STANDARD 440):

### a. Cooling mode (2-pipe/ 4-pipe):

- Return air temperature: DB 80°F/WB
- Inlet/ outlet water temperature: 45°F/ 55°F

### b. Heating mode (4-pipe):

- Return air temperature: 70°F
- Inlet/outlet water temperature: 180°F/140°F

(All dimensions are approximate within 1/16 of an inch of those indicated)



# TECHNICAL SPECIFICATIONS

Hydronic Double Skin Ducted Unit; 4R+2 (Auxiliary Heating Coil); 4 pipe, with **EC Motor**

UNIT GENERAL SPECS	PDWD-4R+2-[Size]-P-AECM		400	800	1200	1600	2000
	Configuration		4-pipe				
	Number of Fan Blowers		Single	Twin			Four
	Power Supply (V/Ph/Hz)		208-240 / 1 / 60				
AIR	Total Air Flow	H	479	1069	1534	1720	3440
		M	374	1012	1330	1470	2940
		L	180	338	551	815	1631
	External Static Pressure	H	0.2				
		M					
		L					
COOLING	Total Cooling Capacity	H	17244	35410	50439	57843	104886
		M	14306	33881	45062	51332	92823
		L	8009	14490	22601	32653	59500
	Sensible Cooling Capacity	H	11356	23670	33607	38202	70750
		M	9283	22588	29879	33544	62186
		L	5043	9231	14375	20816	38751
HEATING	Heating Capacity	H	22139	45644	63756	73294	131591
		M	18367	43672	56960	65043	116457
		L	10282	18678	28568	41375	74649
SOUND	Pressure Level (Outlet)		56/53/43	58/56/47	56/52/45	60/58/50	65/63/60
	Pressure Level (Inlet + Radiated)		59/56/46	61/59/50	57/55/48	63/61/53	65/63/60
	Power Level (Outlet)		65/62/52	67/65/56	65/61/54	69/67/59	74/72/69
	Power Level (Inlet + Radiated)		68/65/55	70/68/59	68/64/57	72/70/62	74/72/69
ELECTRICAL	Power Input	H	202	281	310	477	672
		M	121	208	151	304	546
		L	34	65	70	108	280
	Running Current 220V (H)		A	1.83	2.55	2.81	4.33
HYDRONIC	Cooling Water Flow Rate	H	3.41	6.99	9.96	11.42	20.71
		M	2.83	6.69	8.9	10.14	18.33
		L	1.58	2.86	4.46	6.45	11.75
	Cooling Pressure Drop	H	50.95	38.41	82.4	41.33	144.14
		M	36.4	35.48	67.27	33.34	115.68
		L	12.81	7.69	19.43	14.77	51.95
	Heating Water Flow Rate	H	1.1	2.27	3.18	3.65	6.56
		M	0.91	2.18	2.84	3.24	5.8
		L	0.51	0.93	1.42	2.06	3.72
	Heating Pressure Drop	H	2.47	1.88	4.01	2	6.96
		M	1.77	1.74	3.27	1.62	5.58
		L	0.62	0.38	0.94	0.72	2.51
Chilled water content		Gal	0.33	0.47	0.62	0.86	0.97
Hot water content			0.11	0.16	0.21	0.29	0.32

**TESTING CONDITIONS (RATED AT AHRI STANDARD 440):**

**a. Cooling mode (2-pipe/ 4-pipe):**

- Return air temperature: DB 80°F/WB 67°F
- Inlet/ outlet water temperature: 45°F/ 55°F

**b. Heating mode (4-pipe):**

- Return air temperature: 70°F
- Inlet water temperature: 180°F/140°F

(All dimensions are approximate within 1/16 of an inch of those indicated)

# DIMENSIONAL DRAWINGS, DATA & WEIGHTS

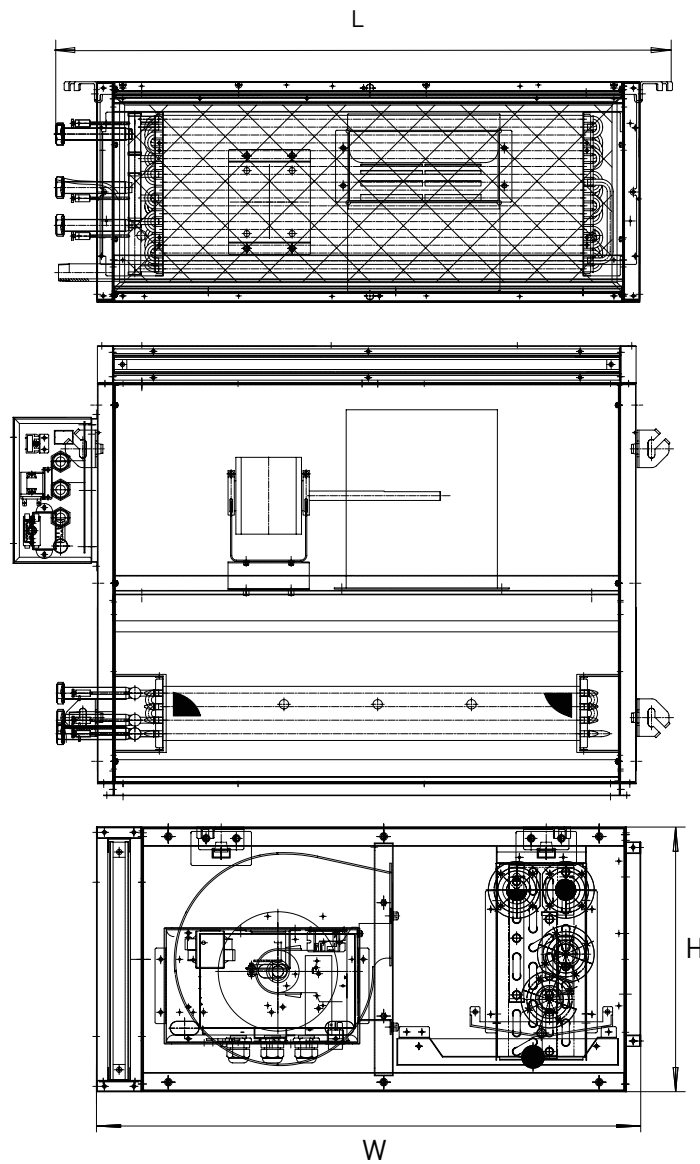

PDWD			400	800	1200	1600	2000
CONSTRUCTION AND PACKING DATA	Water Connections	Type	FNPT (Threaded Female)				
		In	3/4				
	Out	1					
	Condensate Drainage	inch	3/4				
	Dimensions	L	inch	37 1/4	45 1/8	53	64 3/4
W		inch	28 3/8	30 3/4			
H		inch	13 3/4	15 3/4			
WEIGHT	Net Weight (3R, 4R and 3+1R)	lbs	114	126	145	160	185
	Net Weight (6R and 4+2R)		126	138	161	178	200

# HAHU - HORIZONTAL MINI AIR HANDLING UNIT

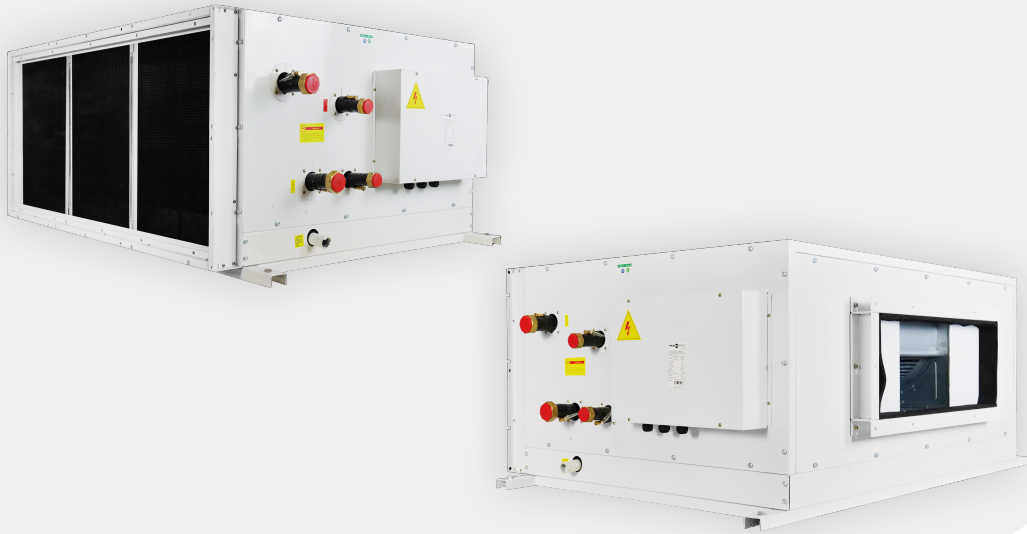

## FEATURES

### CONTROL FLEXIBILITY

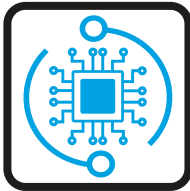

Two types of control system: Intelligent control board (I-Control) controlled via Infra-red handset and/or Intelligent wired wall pad or Flexible control (W-Control) permitting operation with external thermostat applications both controls allows configuration for 2 or 4-pipe settings.

### EFFICIENT EC MOTOR



EC motors allow the centrifugal fans to operate at optimum airflow performance, energy efficiency and quiet operation. EC motors include driven control PCB, constant torque, permanent magnet and 3 speeds pre-set or modulating with a 0-10 VDC signal for precise air balancing control.

### FAN BLOWER

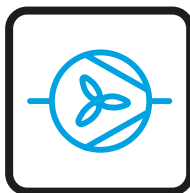

Galvanized steel housing center plate fixed impeller, with riveting compression on the end ring and galvanized steel sheet mounting feet to ensure adequate strength, All impellers and motors are fully balanced according to ANSI/AMCA-204 standard for smooth and quiet operation.

## STRUCTURE

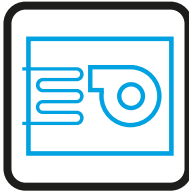

Made from frameless integrated folded steel structure, it uses a sandwich panel consisting of two walls with high-pressure PU foam inner insulation. It has couplings for the connection of ducting and gravity drain pan with insulation for condensation. The unit has an easy access to fans, motors and filters.

## WATER COILS



Built with seamless copper tubes and headers, mechanically expanded into corrugated aluminium fin material for a permanent primary to secondary surface bond. Tested at 500 psi, with maximum operating limits at 300 psi.

## READY TO INSTALL



The Horizontal Mini Air Handling unit range is offered as a complete package including standard items such as a powder-coated steel internal drain pan, double sandwich panel insulation of 0.4" + 1", and a MERV 4 filter. Furthermore, we offer multiple optional accessories.

## KEY POINTS

- Auto Dynamic Balancing with I-Control
- External Static Pressure up to 1.4 in.wg
- Compact dimension with Cooling capacity around 200 MBH and 5300 CFM of airflow available
- 5 and 6 Rows configurations available



## ACCESSORIES

- IR Handset or Wired Wall Pad (Available with I-Control)
- Thermostat Controller (Available with W-Control)
- Merv 8 or MERV 14 Filters
- Electric heater up to 9kW
- 2 or 3 Way On/Off & Modulating Valves
- Belimo Valve Kit
- Integrated Condensate Pump
- Supply/Return air Plenum
- Stainless Steel Drain Pan

\*Please refer to page 86 for further information and accessories.



# TECHNICAL SPECIFICATIONS

Hydronic Horizontal Mini AHU Ductable Unit, 5R; 2 pipes with **EC Motor**

UNIT GENERAL SPECS	HAHU-5R-[Size]-V-AECM		200	300	400	600	800
	Configuration		2-pipe				
	Number of Fan Blowers		1			2	
	Power Supply (V/Ph/Hz)		208-240/1/60				
AIR	Total Air Flow	H	1307	1859	2408	3718	4815
		M	1125	1590	2056	3180	4112
		L	801	1127	1456	2255	2912
	External Static Pressure	H	0.48				
		M					
		L					
COOLING	Total Cooling Capacity	H	49537	70417	88274	136284	171477
		M	44113	62375	77939	120720	151400
		L	34084	47615	59505	92153	115591
	Sensible Cooling Capacity	H	32931	46619	58853	90576	114718
		M	29145	40889	51371	79443	100133
		L	22160	30819	38787	59878	75605
HEATING	Heating Capacity	H	77008	109466	137226	211859	266569
		M	68575	96965	121159	187665	235359
		L	52985	74019	92503	143256	179691
	Max. Electric Heater Capacity @ 115V	kw	4.5	6	7.5	9	
SOUND	Pressure Level (Outlet)	dB(A)	67/62/58	72/67/63	74/69/65	75/70/66	77/72/67
	Pressure Level (Inlet + Radiated)		70/65/61	75/70/66	77/72/68	78/73/69	80/75/70
	Power Level (Outlet)		76/71/67	75/76/72	83/78/74	84/79/75	86/81/76
	Power Level (Inlet + Radiated)		79/74/70	84/79/75	86/81/77	87/82/78	89/84/79
ELECTRICAL	Power Input	H	412	850	1015	1700	2030
		M	375	650	850	1300	1530
		L	320	350	500	700	1000
	Running Current 220V (H)	A	3.7	7.7	9.2	15.5	18.5
HYDRONIC	Cooling Water Flow Rate	H	9.8	13.9	17.4	26.9	33.9
		M	8.7	12.3	15.4	23.8	29.9
		L	6.7	9.4	11.8	18.2	22.8
	Cooling Pressure Drop	H	8	17.2	8.1	13	11.7
		M	6.5	13.8	6.4	10.4	9.3
		L	4.1	8.5	4	6.4	5.7
	Heating Water Flow Rate	H	Same as cooling water flow rate				
		M					
		L					
	Heating Pressure Drop	H	7.2	15.5	7.3	11.7	10.5
M		5.8	12.5	5.8	9.4	8.4	
L		3.7	7.7	3.6	5.8	5.2	
Water Content	Gal	2.43	3.01	3.59	4.15	5.02	

**TESTING CONDITIONS (RATED AT AHRI STANDARD 440):**

**a. Cooling mode (2-pipe/ 4-pipe):**

- Return air temperature: DB 80°F/WB 67°F
- Inlet/ outlet water temperature: 45°F/ 55°F

**b. Heating mode (2-pipe):**

- Return air temperature: 70°F
- Inlet water temperature: 140°F
- Water flow-rate: Same as cooling mode

# TECHNICAL SPECIFICATIONS

Hydronic Horizontal Mini AHU Ductable Unit, 6R; 2 pipes with **EC Motor**

UNIT GENERAL SPECS	HAHU-6R-[Size]-V-AECM		200	300	400	600	800
	Configuration		2-pipe				
	Number of Fan Blowers		1			2	
	Power Supply (V/Ph/Hz)		208-240/1/60				
AIR	Total Air Flow	H	1242	1812	2364	3625	4728
		M	1084	1561	2028	3122	4057
		L	779	1111	1441	2223	2882
External Static Pressure	in.wg	H	0.48				
		M					
		L					
COOLING	Total Cooling Capacity	H	51587	74896	97886	147731	191080
		M	46432	66702	86942	131569	169717
		L	36161	51119	66961	100831	130712
	Sensible Cooling Capacity	H	33857	49014	63970	96618	124995
		M	30232	43179	56175	85116	109764
		L	23234	32723	42812	64504	83653
HEATING	Heating Capacity	H	80194	116429	152168	229655	297043
		M	72180	103691	135155	204529	263833
		L	56214	79467	104093	156747	203197
	Max. EH capacity		kw	4.5	6	7.5	9
SOUND	Pressure Level (Outlet)		67/62/58	67/62/58	72/67/63	74/69/65	75/70/66
	Pressure Level (Inlet + Radiated)		70/65/61	70/65/61	75/70/66	77/72/68	78/73/69
	Power Level (Outlet)		76/71/67	76/71/67	81/76/72	83/78/74	84/79/75
	Power Level (Inlet + Radiated)		79/74/70	79/74/70	84/79/75	86/81/77	87/82/78
ELECTRICAL	Power Input	H	412	850	1015	1700	2030
		M	375	650	850	1300	1530
		L	320	350	500	700	1000
Running Current 220V (H)		A	3.7	7.7	9.2	15.5	18.5
HYDRONIC	Cooling Water Flow Rate	H	10.2	14.8	19.3	29.2	37.7
		M	9.2	13.2	17.2	26	33.5
		L	7.1	10.1	13.2	19.9	25.8
	Cooling Pressure Drop	H	10.3	23	42	33.1	57.5
		M	8.6	18.7	33.9	26.9	46.5
		L	5.5	11.6	21.2	16.6	29.0
	Heating Water Flow Rate	H	Same as cooling water flow rate				
		M					
		L					
	Heating Pressure Drop	H	9.3	20.7	37.8	29.8	51.8
M		7.7	16.8	30.5	24.2	41.8	
L		4.9	10.4	19.1	15	26.1	
Water Content		Gal	2.9	3.6	4.3	5	6

## TESTING CONDITIONS (RATED AT AHRI STANDARD 440):

### a. Cooling mode (2-pipe/ 4-pipe):

- Return air temperature: DB 80°F/WB 67°F
- Inlet/ outlet water temperature: 45°F/ 55°F

### b. Heating mode (2-pipe):

- Return air temperature: 70°F
- Inlet water temperature: 140°F
- Water flow-rate: Same as cooling mode

# TECHNICAL SPECIFICATIONS

Hydronic Horizontal Mini AHU Unit, 5R+2 (Auxiliary Heating Coil); 4 pipe with **EC Motor**

UNIT GENERAL SPECS	HAHU-5R+2-[Size]-P-AECM		200	300	400	600	800
	Configuration		4-pipe				
	Number of Fan Blowers		1			2	
	Power Supply (V/Ph/Hz)		208-240/1/60				
AIR	Total Air Flow	H	1176	1765	2319	3529	4638
		M	1043	1531	2000	3062	4001
		L	756	1095	1426	2191	2851
External Static Pressure	H	0.48					
	M						
	L						
COOLING	Total Cooling Capacity	H	45469	67401	85699	130447	166474
		M	41739	60841	76583	117751	148767
		L	32513	46451	58759	89900	114143
	Sensible Cooling Capacity	H	30114	44535	57060	86528	111222
		M	27399	39782	50418	77293	98275
		L	21103	30037	38283	58360	74622
HEATING	Heating Capacity	H	50705	73232	94434	142327	181021
		M	46546	66105	84389	128474	161766
		L	36257	50469	64748	98087	124116
SOUND	Pressure Level (Outlet)		67/62/58	67/62/58	72/67/63	74/69/65	75/70/66
	Pressure Level (Inlet + Radiated)		70/65/61	70/65/61	75/70/66	77/72/68	78/73/69
	Power Level (Outlet)		76/71/67	76/71/67	81/76/72	83/78/74	84/79/75
	Power Level (Inlet + Radiated)		79/74/70	79/74/70	84/79/75	86/81/77	87/82/78
ELECTRICAL	Power Input	H	412	850	1015	1700	2030
		M	375	650	850	1300	1530
		L	320	350	500	700	1000
	Running Current 220V (H)		A	3.7	7.7	9.2	15.5
HYDRONIC	Cooling Water Flow Rate	H	9.0	13.3	16.9	25.8	32.9
		M	8.2	12.0	15.1	23.3	29.4
		L	6.4	9.2	11.6	17.8	22.5
	Cooling Pressure Drop	H	6.8	15.9	7.6	12.0	11.1
		M	5.9	13.2	6.2	10.0	9.0
		L	3.7	8.1	3.9	6.1	5.6
	Heating Water Flow Rate	H	2.5	3.7	4.7	7.1	9.0
		M	2.3	3.3	4.2	6.4	8.1
		L	1.8	2.5	3.2	4.9	6.2
	Heating Pressure Drop	H	1.4	3.3	1.6	4.6	2.5
		M	1.2	2.7	1.3	3.8	2.1
		L	0.8	1.7	0.8	2.4	1.3
Chilled Water content		Gal	2.9	3.6	4.3	5.0	6.0
Hot Water content		Gal	1.0	1.2	1.4	1.7	2.0

**TESTING CONDITIONS (RATED AT AHRI STANDARD 440):**

**a. Cooling mode (2-pipe/ 4-pipe):**

- Return air temperature: DB 80°F/WB 67°F
- Inlet/ outlet water temperature: 45°F/ 55°F

**b. Heating mode (4-pipe):**

- Return air temperature: 70°F
- Inlet/outlet water temperature: 180°F/140°F

(All dimensions are approximate within 1/16 of an inch of those indicated)



# TECHNICAL SPECIFICATIONS

Hydronic Horizontal Mini AHU Unit, 6R+2 (Auxiliary Heating Coil); 4 pipe with **EC Motor**

UNIT GENERAL SPECS	HAHU-6R+2-[Size]-V-AECM		200	300	400	600	800
	Configuration		4-pipe				
	Number of Fan Blowers		1			2	
	Power Supply (V/Ph/Hz)		208-240/1/60				
AIR	Total Air Flow	H	1063	1684	2242	3367	4485
		M	976	1483	1955	2966	3910
		L	723	1071	1403	2142	2806
External Static Pressure	in.wg	H	0.48				
		M	0.48				
		L	0.48				
COOLING	Total Cooling Capacity	H	45695	71072	93539	140189	182595
		M	43021	64402	84654	127032	165251
		L	34029	49854	65283	98336	127437
	Sensible Cooling Capacity	H	29696	46353	60908	91373	119012
		M	27820	41592	54597	81987	106681
		L	21815	31882	41698	62848	81477
HEATING	Heating Capacity	H	46924	71048	91596	138082	175581
		M	44178	64380	82896	125122	158903
		L	34944	49837	63927	96858	122542
SOUND	Pressure Level (Outlet)		67/62/58	67/62/58	72/67/63	74/69/65	75/70/66
	Pressure Level (Inlet + Radiated)		70/65/61	70/65/61	75/70/66	77/72/68	78/73/69
	Power Level (Outlet)		76/71/67	76/71/67	81/76/72	83/78/74	84/79/75
	Power Level (Inlet + Radiated)		79/74/70	79/74/70	84/79/75	86/81/77	87/82/78
ELECTRICAL	Power Input	H	412	850	1015	1700	2030
		M	375	650	850	1300	1530
		L	320	350	500	700	1000
	Running Current 220V (H)		A	3.7	7.7	9.2	15.5
HYDRONIC	Cooling Water Flow Rate	H	9.0	14.0	18.5	27.7	36.1
		M	8.5	12.7	16.7	25.1	32.6
		L	6.7	9.8	12.9	19.4	25.2
	Cooling Pressure Drop	H	8.3	20.9	38.7	30.1	53.0
		M	7.5	17.5	32.3	25.2	44.3
		L	4.9	11.1	20.2	15.9	27.7
	Heating Water Flow Rate	H	2.3	3.5	4.6	6.9	8.8
		M	2.2	3.2	4.1	6.2	7.9
		L	1.7	2.5	3.2	4.8	6.1
	Heating Pressure Drop	H	1.2	3.1	1.5	4.4	2.4
		M	1.1	2.6	1.2	3.7	2.0
		L	0.7	1.6	0.8	2.3	1.3
Chilled Water content		Gal	2.9	3.6	4.3	5.0	6.0
Hot Water content			1.0	1.2	1.4	1.7	2.0

## TESTING CONDITIONS (RATED AT AHRI STANDARD 440):

### a. Cooling mode (2-pipe/ 4-pipe):

- Return air temperature: DB 80°F/WB 67°F
- Inlet/ outlet water temperature: 45°F/ 55°F

### b. Heating mode (4-pipe):

- Return air temperature: 70°F
- Inlet water temperature: 180°F/140°F

(All dimensions are approximate within 1/16 of an inch of those indicated)

# DIMENSIONAL DRAWINGS, DATA & WEIGHTS

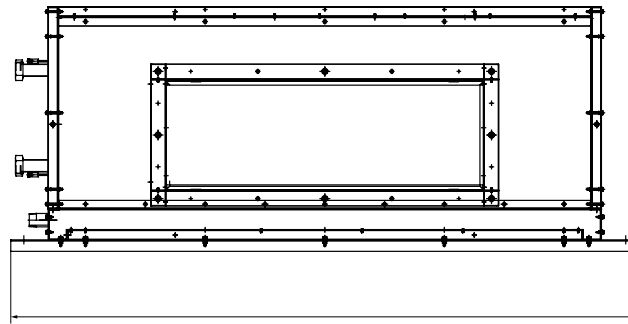

L

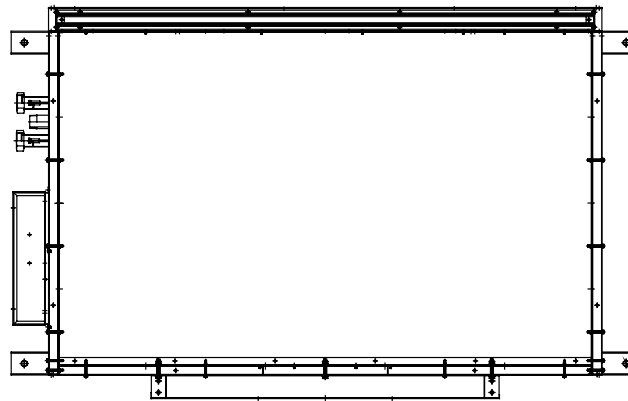

W

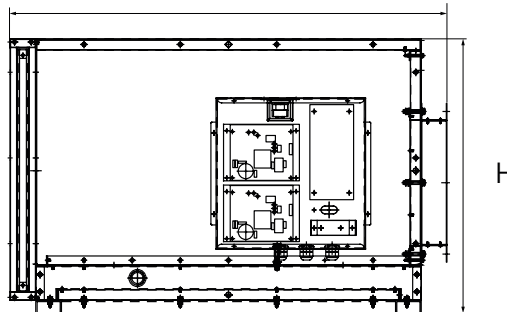

H

HAHU			200	300	400	600	800
CONSTRUCTION AND PACKING DATA	Water Connections	Type	FNPT (Threaded Female)				
		In					
	Condensate Drainage Connection	Out	1 1/4				
		inch	1				
	Heating Water Connections (Only 4 pipes)	In					
		Out	1				
Dimensions	L	50 3/8	58 1/4	66 1/8	76	83 7/8	
	W	44 1/8					
	H	29 11/16					
WEIGHT	Net Weight	lbs	From 330 to 364	From 386 to 408	From 410 to 463	From 492 to 551	From 496 to 623

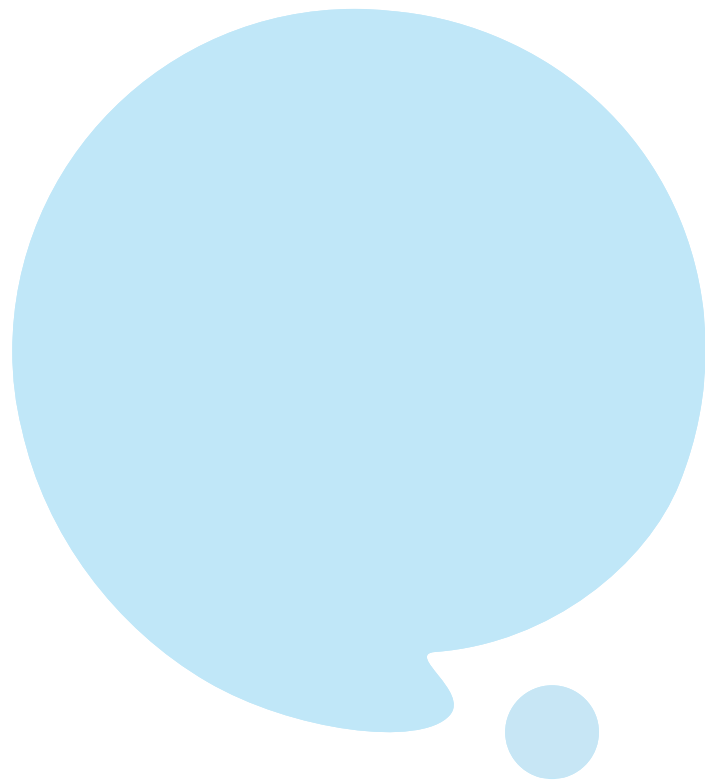

# VAHU - VERTICAL MINI AIR HANDLING UNIT

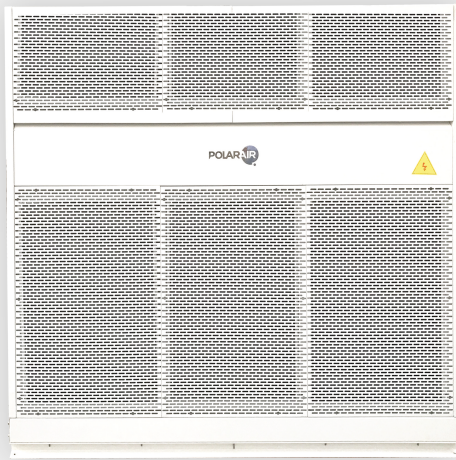

## FEATURES

### CONTROL FLEXIBILITY

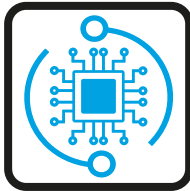

Two types of control system: Intelligent control board (I-Control) controlled via Infra-red handset and/or Intelligent wired wall pad or Flexible control (W-Control) permitting operation with external thermostat applications both controls allows configuration for 2 or 4-pipe settings.

### EFFICIENT EC MOTOR

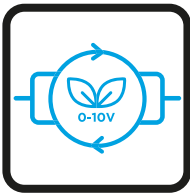

EC motors allow the centrifugal fans to operate at optimum airflow performance, energy efficiency and quiet operation. EC motors include driven control PCB, constant torque, permanent magnet and 3 speeds pre-set or modulating with a 0-10 VDC signal for precise air balancing control.

### FAN BLOWER

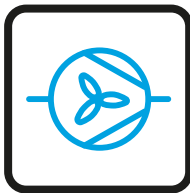

Galvanized steel housing center plate fixed impeller, with riveting compression on the end ring and galvanized steel sheet mounting feet to ensure adequate strength, All impellers and motors are fully balanced according to ANSI/AMCA-204 standard for smooth and quiet operation.

## STRUCTURE

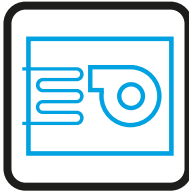

Made from frameless integrated folded steel structure, it uses a sandwich panel consisting of two walls with high-pressure PU foam inner insulation. It has couplings for the connection of ducting and gravity drain pan with insulation for condensation. The unit has an easy access to fans, motors and filters.

## WATER COILS



Built with seamless copper tubes and headers, mechanically expanded into corrugated aluminium fin material for a permanent primary to secondary surface bond. Tested at 500 psi, with maximum operating limits at 300 psi.

## READY TO INSTALL



The Vertical Mini Air Handling unit range is offered as a complete package including standard items such as a powder-coated steel internal drain pan, double sandwich panel insulation of 0.4" + 1", and a MERV 4 filter. Furthermore, we offer multiple optional accessories.

## KEY POINTS

- Auto Dynamic Balancing with I-Control
- External Static Pressure up to 1.4 in.wg
- Suitable for special applications with Cooling capacity around 180 MBH and 5300 CFM of airflow available
- Upflow or downflow discharge



## ACCESSORIES

- IR Handset or Wired Wall Pad (Available with I-Control)
- Thermostat Controller (Available with W-Control)
- Merv 8 or MERV 14 Filters
- Electric heater up to 9kW
- 2 or 3 Way On/Off & Modulating Valves
- Belimo Valve Kit
- Integrated Condensate Pump
- Stainless Steel Drain Pan

\*Please refer to page 86 for further information and accessories.



# TECHNICAL SPECIFICATIONS

Hydronic Vertical Mini Ahu Ductable Unit, 5 Row, 2 pipe with **EC Motor**

UNIT GENERAL SPECS	VAHU-5R-[Size]-V-AECM			200	300	400	600	800
	Configuration			2-pipe				
	Number of Fan Blowers			1			2	
	Power Supply (V/Ph/Hz)			208-240/1/60				
AIR	Total Air Flow	H	CFM	1307	1859	2408	3718	4815
		M		1125	1590	2056	3180	4112
		L		801	1127	1456	2255	2912
	External Static Pressure	H	in.wg	0.48				
		M						
		L						
COOLING	Total Cooling Capacity	H	BTU/Hr	49198	69779	88889	129802	170608
		M		43810	61810	78482	114978	150632
		L		33850	47183	59919	87770	115005
	Sensible Cooling Capacity	H		32685	46268	59169	87116	113815
		M		28927	40582	51646	76409	99345
		L		21994	30587	38995	57590	75010
HEATING	Heating Capacity	H	BTU/Hr	76481	108474	138182	201783	265217
		M		68105	96086	122003	178739	234165
		L		52622	73348	93147	136442	178780
	Max. EH capacity		kW	4.5	6	7.5	9	
SOUND	Pressure Level (Outlet)		dB(A)	67/62/58	72/67/63	74/69/65	75/70/66	77/72/67
	Pressure Level (Inlet + Radiated)			70/65/61	75/70/66	77/72/68	78/73/69	80/75/70
	Power Level (Outlet)			76/71/67	75/76/72	83/78/74	84/79/75	86/81/76
	Power Level (Inlet + Radiated)			79/74/70	84/79/75	86/81/77	87/82/78	89/84/79
ELECTRICAL	Power Input	H	W	412	850	1015	1700	2030
		M		375	650	850	1300	1530
		L		320	350	500	700	1000
	Running Current 220V (H)		A	3.7	7.7	9.2	15.5	18.5
HYDRONIC	Cooling Water Flow Rate	H	GPM	9.72	13.78	17.55	25.63	33.69
		M		8.65	12.21	15.5	22.71	29.75
		L		6.68	9.32	11.83	17.33	22.71
	Cooling Pressure Drop	H	Ft. wg.	14.51	17.27	10.22	10.27	19.68
		M		11.78	13.88	8.17	8.26	15.73
		L		7.4	8.54	5.03	5.08	9.68
	Heating Water Flow Rate	H	GPM	Same as cooling water flow rate				
		M						
		L						
	Heating Pressure Drop	H	Ft. wg.	13.06	15.54	9.2	9.24	17.71
		M		10.6	12.5	7.35	7.43	14.16
		L		6.66	7.69	4.52	4.57	8.71
Water Content		Gal	2.48	3.25	4.02	4.78	5.92	

**TESTING CONDITIONS (RATED AT AHRI STANDARD 440):**

**a. Cooling mode (2-pipe/ 4-pipe):**

- Return air temperature: DB 80°F/WB 67°F
- Inlet/ outlet water temperature: 45°F/ 55°F

**b. Heating mode (2-pipe):**

- Return air temperature: 70°F
- Inlet water temperature: 180°F/140°F
- Water flow-rate: Same as cooling mode

(All dimensions are approximate within 1/16 of an inch of those indicated)

# TECHNICAL SPECIFICATIONS

Hydronic Vertical Mini AHU Unit, 5R+2 (Auxiliary Heating Coil), 4 pipe with **EC Motor**

UNIT GENERAL SPECS	VAHU-5R+2-[Size]-P-AECM			200	300	400	600	800
	Configuration			4 pipe				
	Number of Fan Blowers			1			2	
	Power Supply (V/Ph/Hz)			208-240/1/60				
AIR	Total Air Flow	H	CFM	1176	1765	2319	3529	4638
		M		1043	1531	2000	3062	4001
		L		756	1095	1426	2191	2851
	External Static Pressure	H	in.wg	0.2				
		M						
		L						
COOLING	Total Cooling Capacity	H	BTU/Hr	45157	66790	86296	124243	165630
		M		41453	60289	77117	112150	148013
		L		32291	46030	59168	85624	113564
	Sensible Cooling Capacity	H		29889	44200	57365	83222	110347
		M		27194	39483	50688	74340	97502
		L		20945	29812	38488	56130	74034
HEATING	Heating Capacity	H	BTU/Hr	49439	82113	94796	135954	177803
		M		45383	74120	84713	122721	158891
		L		35352	56589	64996	93695	121910
SOUND	Pressure Level (Outlet)		dB(A)	67/62/58	67/62/58	72/67/63	74/69/65	75/70/66
	Pressure Level (Inlet + Radiated)			70/65/61	70/65/61	75/70/66	77/72/68	78/73/69
	Power Level (Outlet)			76/71/67	76/71/67	81/76/72	83/78/74	84/79/75
	Power Level (Inlet + Radiated)			79/74/70	79/74/70	84/79/75	86/81/77	87/82/78
ELECTRICAL	Power Input	H	W	412	850	1015	1700	2030
		M		375	650	850	1300	1530
		L		320	350	500	700	1000
	Running Current 220V (H)		A	3.7	7.7	9.2	15.5	18.5
HYDRONIC	Cooling Water Flow Rate	H	GPM	8.92	13.19	17.04	24.56	32.71
		M		8.19	11.91	15.23	22.15	29.23
		L		6.38	9.09	11.68	16.91	22.43
	Cooling Pressure Drop	H	Ft. wg.	12.44	15.96	9.69	9.49	18.66
		M		10.66	13.28	7.92	7.89	15.24
		L		6.8	8.17	4.91	4.86	9.46
	Heating Water Flow Rate	H	GPM	2.46	4.09	4.72	6.77	8.86
		M		2.26	3.69	4.22	6.11	7.91
		L		1.76	2.82	3.24	4.67	6.07
	Heating Pressure Drop	H	Ft. wg.	0.8	2.02	3.73	3.65	7.15
		M		0.69	1.68	3.05	3.04	5.84
		L		0.44	1.03	1.89	1.87	3.63
Chilled Water content		Gal	2.48	3.25	4.02	4.78	5.92	
Hot Water content			0.99	1.3	1.61	1.91	2.37	

## TESTING CONDITIONS (RATED AT AHRI STANDARD 440):

### a. Cooling mode (2-pipe/ 4-pipe):

- Return air temperature: DB 80°F/WB 67°F
- Inlet/ outlet water temperature: 45°F/ 55°F

### b. Heating mode (4-pipe):

- Return air temperature: 70°F
- Inlet/outlet water temperature: 180°F/140°F

# DIMENSIONAL DRAWINGS, DATA & WEIGHTS

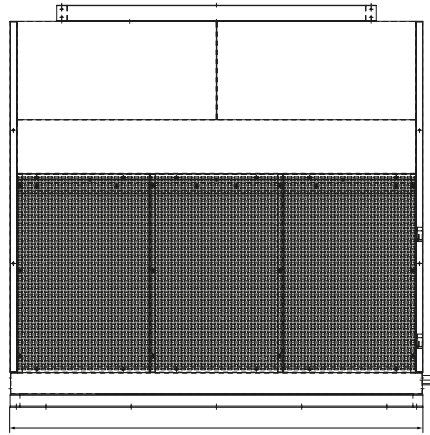

L

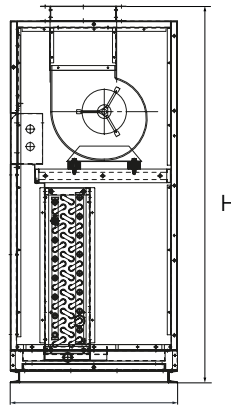
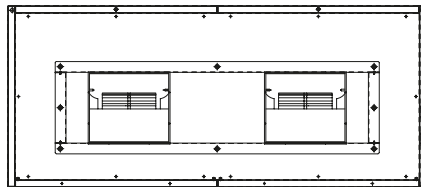

W

VAHU			200	300	400	600	800
CONSTRUCTION AND PACKING DATA	Cooling Water Connections	Type	FNPT (Threaded Female)				
		In	1 1/4				
	Out						
	Condensate Drainage Connection	inch	1				
	Heating Water Connections (Only 4 pipes)	In	1				
		Out					
Dimensions	L	inch	33 7/16	41 5/16	49 3/16	61	74
	W	26 3/8					
	H	59 7/16					
WEIGHT	NET WEIGHT From - to	lbs	330 to 415	370 to 470	410 to 523	490 to 623	560 to 623



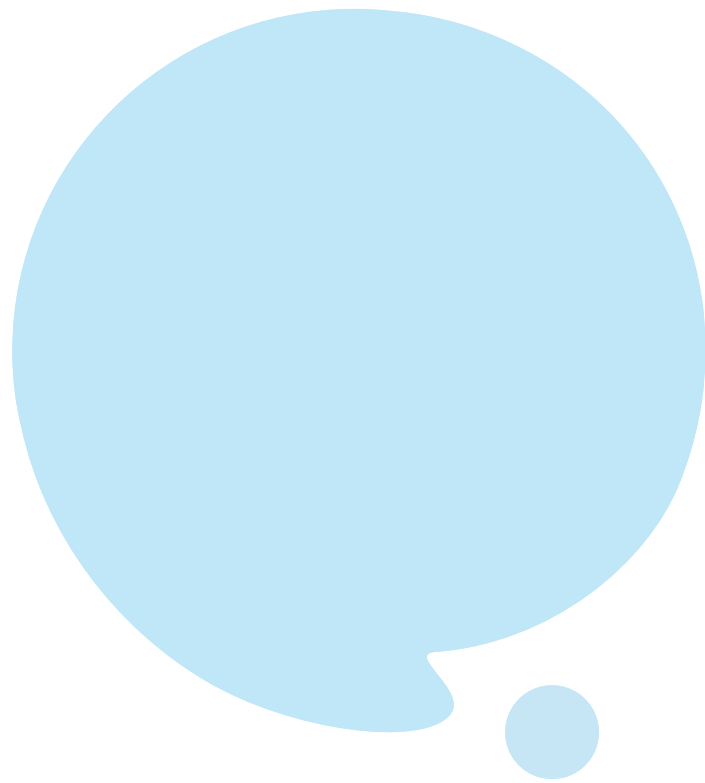

# PFWBC - STANDARD CONSOLE

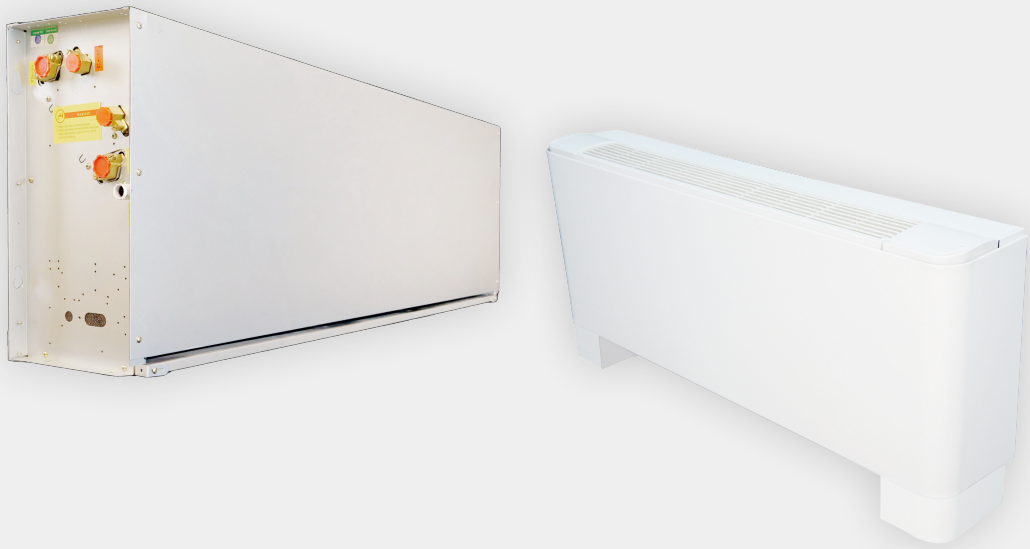

## FEATURES

---

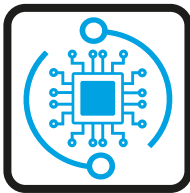

### CONTROL FLEXIBILITY

Two types of control system: Intelligent control board (I-Control) controlled via Infra-red handset and/or Intelligent wired wall pad or Flexible control (W-Control) permitting operation with external thermostat applications both controls allows configuration for 2 or 4-pipe settings.

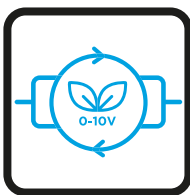

### EFFICIENT EC MOTOR

EC motors allow the centrifugal fans to operate at optimum airflow performance, energy efficiency and quiet operation. EC motors include driven control PCB, constant torque, permanent magnet and 3 speeds pre-set or modulating with a 0-10 VDC signal for precise air balancing control.

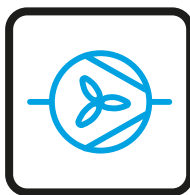

### FAN BLOWER

Centrifugal type with double air inlet blades made of forward-curving metal fins, and with large diameters to create high airflow and high static pressure with fewer revolutions offering lower noise levels.

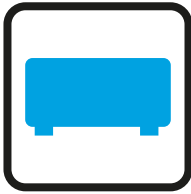

## STRUCTURE

Made of galvanized sheet steel designed to be attached to the wall or the ceiling, with fire-resistant thermo-acoustic insulation internally fitted. Installation can be vertical or horizontal, thanks to the "V" type drain pan accessory.

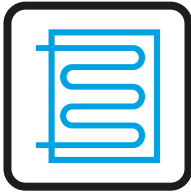

## WATER COILS

Built with seamless copper tubes and headers, mechanically expanded into corrugated aluminium fin material for a permanent primary to secondary surface bond. Tested at 500 psi, with maximum operating limits at 300 psi.



## READY TO INSTALL

The PFWB(C) range is offered as a complete package including standard items such as a cabinet with air grille distributions, a Galvanized Steel internal drain pan, 0.2" NBR Insulation and MERV 4 filter.

Furthermore, we offer multiple optional accessories.

## KEY POINTS

- Auto Dynamic Balancing with I-Control
- Coil interchangeable on field
- 3 and 4 Rows configurations available
- With or without cabinet and Horizontal or Vertical air return



## ACCESSORIES

- IR Handset or Wired Wall Pad (Available with I-Control)
- Thermostat Controller (Available with W-Control)
- 2 or 3 Way On/Off & Modulating Valves
- Stainless Steel Drain Pan
- Electric heater up to 3kW
- ABS Plastic Supporting Feet

\*Please refer to page 86 for further information and accessories.



# TECHNICAL SPECIFICATIONS

Hydronic Standard Console, 3R, 2 Pipe with **EC Motor**

UNIT GENERAL SPECS			PFWB(C)-3R-[Size]-V-AECM	06	09	12	15	18	24	30	36	40		
			Configuration			2-pipe								
			Number of Fan Blowers			Single	Twin				Four			
			Power Supply (V/Ph/Hz)			110-120/1/60						208-240/1/60		
AIR	Total Air Flow	H	CFM	206	296	398	494	571	794	955	1169	1333		
		M		165	254	318	410	486	688	847	1006	1196		
		L		124	201	224	255	289	398	435	524	559		
COOLING	Total Cooling Capacity	H	BTU/Hr	6204	8658	11209	14284	16545	22823	27205	31555	36130		
		M		5308	7706	9557	12465	14580	20497	25146	28412	33533		
		L		4222	6459	7252	8670	9809	13351	14892	16972	18783		
	Sensible Cooling Capacity	H		4196	5885	7681	9698	11131	15455	18374	21713	24650		
		M		3540	5179	6453	8357	9725	13735	16827	19338	22766		
		L		2794	4314	4840	5703	6397	8723	9675	11228	12298		
HEATING	Heating Capacity	H	BTU/Hr	9644	13460	17425	22206	25719	35480	42291	49054	56165		
		M		8251	11979	14856	19377	22665	31863	39090	44168	52128		
		L		6563	10041	11274	13478	15249	20755	23151	26384	29199		
	Max. Electric Heater Capacity @ 115V	kw		1			1.5			2			3	
0.5			0.75			1			1.5					
SOUND	Pressure Level		dB(A)	41/35/29	43/38/33	47/40/33	49/44/33	51/46/33	52/48/33	54/50/33	57/54/35	60/58/35		
	Power Level			50/44/38	52/47/42	56/49/42	58/53/42	60/55/42	61/57/42	63/59/42	66/63/44	69/67/44		
ELECTRICAL	Power Input	H	W	17	26	38	44	52	87	100	128	182		
		M		13	15	23	30	36	60	71	92	147		
		L		8	11	12	13	14	22	24	28	30		
	Running Current 115V (H)		A	0.3	0.45	0.66	0.77	0.9	1.51	1.74	2.23	3.17		
Running Current 220V (H)		0.15		0.24	0.35	0.4	0.47	0.79	0.91	1.16	1.65			
HYDRONIC	Cooling Water Flow Rate	H	GPM	1.23	1.71	2.21	2.82	3.27	4.51	5.37	6.23	7.13		
		M		1.05	1.52	1.89	2.46	2.88	4.05	4.97	5.61	6.62		
		L		0.83	1.28	1.43	1.71	1.94	2.64	2.94	3.35	3.71		
	Cooling Pressure Drop	H	Ft. hd.	3.17	6.01	3.65	6.41	8.58	8.75	12.96	6.09	8.29		
		M		2.39	4.87	2.74	5.02	6.83	7.21	11.25	5.04	7.25		
		L		1.59	3.55	1.67	2.61	3.35	3.33	4.38	1.99	2.55		
	Heating Water Flow Rate		GPM	Same as cooling water flow rate										
	Heating Pressure Drop	H	Ft. hd.	2.85	5.41	3.29	5.77	7.72	7.87	11.67	5.48	7.46		
		M		2.15	4.39	2.47	4.51	6.15	6.49	10.13	4.54	6.52		
		L		1.43	3.19	1.5	2.35	3.01	3	3.94	1.79	2.3		
Water Content		Gal	0.17	0.19	0.25	0.31	0.33	0.46	0.52	0.58	0.64			

**TESTING CONDITIONS (RATED AT AHRI STANDARD 440):**

**a. Cooling conditions (2-pipe or 4-pipe)**

- Return air temperature: DB 80°F/WB 67°F.
- Inlet/ outlet water temperature: 45/55°F.

**b. Heating conditions (2-pipe)**

- Return air temperature: 70°F
- Inlet water temperature: 140°F
- Water flow-rate: Same as cooling mode.

(All dimensions are approximate within 1/16 of an inch of those indicated)

# TECHNICAL SPECIFICATIONS

Hydronic Standard Console, 4R, 2 Pipe with **EC Motor**

UNIT GENERAL SPECS			PFWB(C)-4R-[Size]-V-AECM	06	09	12	15	18	24	30	36	40		
			Configuration			2-pipe								
			Number of Fan Blowers			Single	Twin				Four			
			Power Supply (V/Ph/Hz)			110-120/1/60						208-240/1/60		
AIR	Total Air Flow	H	CFM	206	296	398	494	571	794	955	1169	1333		
		M		165	254	318	410	486	688	847	1006	1196		
		L		124	201	224	255	289	398	435	524	559		
COOLING	Total Cooling Capacity	H	BTU/Hr	7355	10360	13929	17480	20358	27904	33153	39464	44847		
		M		6293	9220	11876	15253	17941	25060	30643	35534	41623		
		L		5006	7728	9012	10610	12070	16324	18149	21226	23315		
	Sensible Cooling Capacity	H		4889	6879	9209	11554	13355	18414	21830	26240	29658		
		M		4124	6055	7737	9957	11668	16365	19993	23369	27391		
		L		3255	5043	5804	6794	7676	10394	121495	13569	14796		
HEATING	Heating Capacity	H	BTU/Hr	11434	16105	21654	27174	31648	43379	51538	61349	69716		
		M		9783	14333	18462	23712	27890	38957	47637	55239	64704		
		L		7781	12013	14010	16943	18764	25376	28213	32997	36243		
	Max. Electric Heater Capacity @ 115V Max. Electric Heater Capacity @ 220V	kw		1	1.5	2				3				
0.5			0.5	1				1.5						
SOUND	Pressure Level		dB(A)	41/35/29	43/38/33	47/40/33	49/44/33	51/46/33	52/48/33	54/50/33	57/54/35	60/58/35		
	Power Level			50/44/38	52/47/42	56/49/42	58/53/42	60/55/42	61/57/42	63/59/42	66/63/44	69/67/44		
ELECTRICAL	Power Input	H	W	17	26	38	44	52	87	100	128	182		
		M		13	15	23	30	36	60	71	92	147		
		L		8	11	12	13	14	22	24	28	30		
	Running Current 115V (H)		A	0.3	0.45	0.66	0.77	0.9	1.51	1.74	2.23	3.17		
Running Current 220V (H)		0.15		0.24	0.35	0.4	0.47	0.79	0.91	1.16	1.65			
HYDRONIC	Cooling Water Flow Rate	H	GPM	1.45	2.05	2.75	3.45	4.02	5.51	6.55	7.79	8.86		
		M		1.24	1.82	2.35	3.01	3.54	4.95	6.05	7.02	8.22		
		L		0.99	1.53	1.78	2.1	2.38	3.22	3.58	4.19	4.6		
	Cooling Pressure Drop	H	Ft. hd.	5.7	10.92	21.61	37.06	50.17	36.17	53.92	36.47	48.5		
		M		4.3	8.85	16.22	29	39.96	29.8	46.79	30.19	42.4		
		L		2.85	6.44	9.87	15.09	19.58	13.78	18.23	11.94	14.94		
	Heating Water Flow Rate		GPM	Same as cooling water flow rate										
	Heating Pressure Drop	H	Ft. hd.	5.13	9.82	19.45	33.36	45.16	32.55	48.52	32.82	43.65		
		M		3.87	7.96	14.6	26.1	35.97	26.82	42.11	27.17	38.16		
		L		2.57	5.8	8.88	13.58	17.62	12.4	16.4	10.75	13.44		
Water Content		Gal	0.23	0.25	0.33	0.41	0.44	0.61	0.69	0.77	0.85			

### TESTING CONDITIONS (RATED AT AHRI STANDARD 440):

#### a. Cooling conditions (2-pipe or 4-pipe)

- Return air temperature: DB 80°F/WB 67°F.
- Inlet/ outlet water temperature: 45/55°F.

#### b. Heating conditions (2-pipe)

- Return air temperature: 70°F
- Inlet water temperature: 140°F
- Water flow-rate: Same as cooling mode.

(All dimensions are approximate within 1/16 of an inch of those indicated)



# TECHNICAL SPECIFICATIONS

Hydronic Standard Console, 3R+1 (Auxiliary Heating Coil), 4 Pipe with **EC Motor**

UNIT GENERAL SPECS		PFWB(C)-3R+1-[Size]-P-AECM		06	09	12	15	18	24	30	36	40		
		Configuration		4-pipe										
		Number of Fan Blowers		Single	Twin						Four			
		Power Supply (V/Ph/Hz)		110-120/1/60 208-240/1/60										
AIR	Total Air Flow	H	CFM	206	296	398	494	571	794	955	1169	1333		
		M		165	254	318	410	486	688	847	1006	1196		
		L		124	201	224	255	289	398	435	524	559		
COOLING	Total Cooling Capacity	H	BTU/Hr	6204	8658	11209	14284	16545	22823	27205	31555	36130		
		M		5308	7706	9557	12465	14580	20497	25146	28412	33533		
		L		4222	6459	7252	8670	9809	13351	14892	16972	18783		
	Sensible Cooling Capacity	H		4196	5885	7681	9698	11131	15455	18374	21713	24650		
		M		3540	5179	6453	8357	9725	13735	16827	19338	22766		
		L		2794	4314	4840	5703	6397	8723	9675	11228	12298		
HEATING	Heating Capacity	H	BTU/Hr	6497	8816	11747	14594	16377	22719	26783	32154	36533		
		M		5496	7773	9990	12732	14693	20581	24542	28807	33553		
		L		4402	6589	7598	8746	9867	13490	14661	17523	18902		
SOUND	Pressure Level	dB(A)		41/35/29	43/38/33	47/40/33	49/44/33	51/46/33	52/48/33	54/50/33	57/54/35	60/58/35		
	Power Level			50/44/38	52/47/42	56/49/42	58/53/42	60/55/42	61/57/42	63/59/42	66/63/44	69/67/44		
ELECTRICAL	Power Input	H	W	17	26	38	44	52	87	100	128	182		
		M		13	15	23	30	36	60	71	92	147		
		L		8	11	12	13	14	22	24	28	30		
	Running Current 115V (H)	A		0.3	0.45	0.66	0.77	0.9	1.51	1.74	2.23	3.17		
Running Current 220V (H)	0.15			0.24	0.35	0.4	0.47	0.79	0.91	1.16	1.65			
HYDRONIC	Cooling Water Flow Rate	H	GPM	1.23	1.71	2.21	2.82	3.27	4.51	5.37	6.23	7.13		
		M		1.05	1.52	1.89	2.46	2.88	4.05	4.97	5.61	6.62		
		L		0.83	1.28	1.43	1.71	1.94	2.64	2.94	3.35	3.71		
	Cooling Pressure Drop	H	Ft. hd.	3.17	6.01	3.65	6.41	8.58	8.75	12.96	6.09	8.29		
		M		2.39	4.87	2.74	5.02	6.83	7.21	11.25	5.04	7.25		
		L		1.59	3.55	1.67	2.61	3.35	3.33	4.38	1.99	2.55		
	Heating Water Flow Rate	H	GPM	0.32	0.44	0.59	0.73	0.82	1.13	1.33	1.6	1.82		
		M		0.27	0.39	0.5	0.63	0.73	1.03	1.22	1.44	1.67		
		L		0.22	0.33	0.38	0.44	0.49	0.67	0.73	0.87	0.94		
	Heating Pressure Drop	H	Ft. hd.	0.56	1.04	2.07	3.57	4.59	1.5	2.25	3.41	4.46		
		M		0.42	0.83	1.55	2.79	3.77	1.26	1.92	2.8	4		
		L		0.28	0.62	0.95	1.42	1.84	0.59	0.76	1.14	1.42		
Chilled Water Content		Gal		0.17	0.19	0.25	0.31	0.33	0.46	0.52	0.58	0.64		
Hot Water Content				0.06	0.06	0.08	0.1	0.11	0.15	0.17	0.19	0.21		

**TESTING CONDITIONS (RATED AT AHRI STANDARD 440):**

**a. Cooling conditions (2-pipe or 4-pipe)**

- Return air temperature: DB 80°F/WB 67°F.
- Inlet/ outlet water temperature: 45/55°F.

**b. Heating conditions (4-pipe)**

- Return air temperature: 70°F
- Inlet water temperature: 180°F/140°F

(All dimensions are approximate within 1/16 of an inch of those indicated)

# DIMENSIONAL DRAWINGS, DATA & WEIGHTS

## WITHOUT CASING

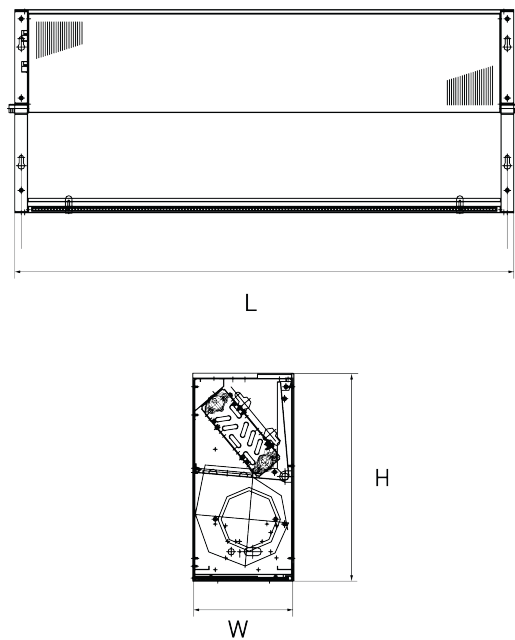

## WITH CASING

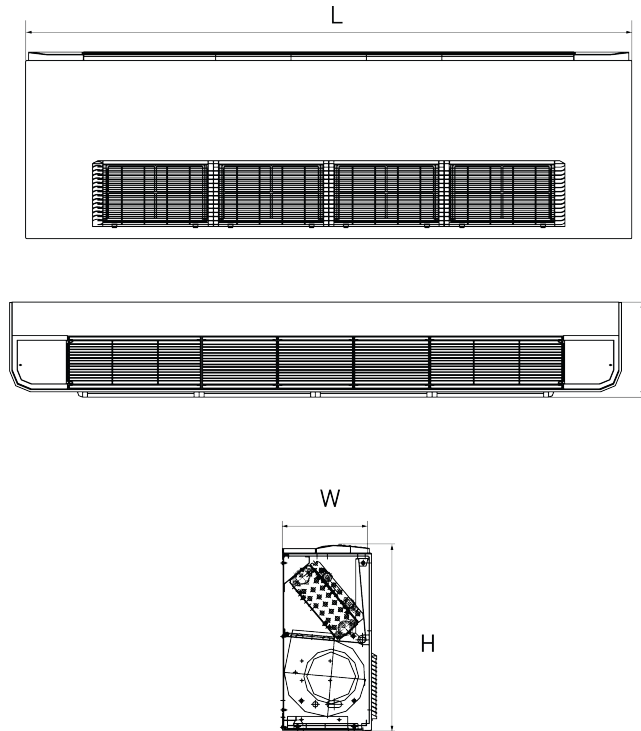

PFWB(C)			06	09	12	15	18	24	30	36	40	
CONSTRUCTION AND PACKING DATA	Cooling Water Connections	Type	FNPT (Threaded Female)									
		In	3/4									
	Out											
	Condensate Drainage Connection		inch									
	Heating Water Connections (Only 4 pipes)	In	1/2									
		Out										inch
	Dimensions Cased Unit	L	inch	33-3/4	35-3/4	41-5/8	47-9/16	49-1/2	69-3/16	69-3/16	75-1/8	81
		W	9-7/8									
H		19-7/16										
Dimensions Uncased Unit	L	inch	23-15/16	25-15/16	31-13/16	37-3/4	39-11/16	53-7/16	59-3/8	65-1/4	71-3/16	
	W	9-1/16										
	H	18-1/8										
WEIGHT	Net Weight (3R and 4R)	lbs	49	53	57	66	71	104	104	108	119	
	Net Weight (3+1R)		51	57	62	71	75	99	108	115	126	

## PFWSL - SLIM CONSOLE



### FEATURES



#### CONTROL FLEXIBILITY

Two types of control system: Intelligent control board (I-Control) with standard built-in control board or Flexible control (W-Control) permitting operation with external thermostat applications both controls allows configuration for 2 or 4-pipe settings.



#### QUIET OPERATION

The adoption of tangential fans mounted on anti-vibration support that provides optimum acoustic comfort.

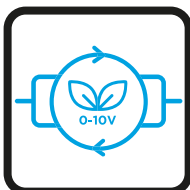

#### EFFICIENT EC MOTOR

EC motors allow the tangential blower wheel to operate at optimum airflow performance, energy efficiency and quiet operation. EC motors include driven control PCB, constant torque, permanent magnet and 3 speeds pre-set or modulating with a 0-10 VDC signal for precise air balancing control.



## SLIM DESIGN

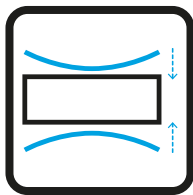

The structure is made of galvanized sheet-steel with holes for attaching the structure to the wall/ceiling. Fire resistant insulation is fitted internally to provide both thermal and acoustic insulation. It has an elegant and modern design, with only 5 3/8" width specially recommended for residential and hospitality applications.

## WATER COILS



Built with seamless copper tubes and headers, mechanically expanded into corrugated aluminium fin material for a permanent primary to secondary surface bond. Tested at 500 psi, with maximum operating limits at 300 psi.

## READY TO INSTALL



The slim console range is offered as a complete package including standard items such as a steel casing with air grille distribution within an integrated built-in control (if choosing I-Control), a galvanized Steel internal drain pan, 0.2" NBR Insulation and MERV 4 filter.

Furthermore, we offer multiple optional accessories.

## KEY POINTS

- Auto Dynamic Balancing with I-Control
- New slim design (5 3/8" width)
- Radiators replacement
- Highest latent performance-dehumidification in the market
- Available with or without cabinet



## ACCESSORIES

- IR Handset or built in control (Available with I-Control)
- Thermostat Controller (Available with W-Control)
- 2 or 3 Way On/Off & Modulating Valves
- Stainless Steel Drain Pan
- Electric heater up to 1.5kW
- Metal Supporting Feet

\*Please refer to page 86 for further information and accessories.



# TECHNICAL SPECIFICATIONS

## Hydronic Slim Console 2 pipe with EC Motor

UNIT GENERAL SPECS	PFWSL-[Size]-V-AECM		01	02	03	04	05	
	Configuration		2-pipe					
	Number of Fan Blowers		1			2		
	Power Supply (V/Ph/Hz)		110-120/1/60					
AIR	Total Air Flow	H	106	174	224	271	353	
		M	82	144	194	218	294	
		L	59	100	135	153	206	
COOLING	Total Cooling Capacity	H	4062	6672	8923	10774	13752	
		M	3354	5795	8014	9218	11997	
		L	2584	4376	6021	6960	9120	
	Sensible Cooling Capacity	H	2674	4414	5854	7066	9073	
		M	2181	3782	5202	5961	7828	
		L	1654	2823	3864	4449	5878	
HEATING	Heating Capacity	H	6315	10372	13872	16749	21377	
		M	5214	9009	12458	14330	18650	
		L	4016	6802	9360	10820	14177	
	Max. Electric Heater Capacity @ 115V		0.75		1		1.5	
Max. Electric Heater Capacity @ 220V		0.75		1		1.5		
SOUND	Pressure Level		43/37/28	43/38/30	45/43/31	46/42/35	47/43/35	
	Power Level		52/46/38	52/47/39	54/52/40	55/51/42	56/52/42	
ELECTRICAL	Power Input	H	16	19	22	24	26	
		M	13	15	17	18	20	
		L	10	11	12	12	12	
	Running Current 115V (H)		0.28		0.33		0.45	
Running Current 220V (H)		0.15		0.17		0.24		
HYDRONIC	Cooling Water Flow Rate	H	0.8	1.32	1.76	2.13	2.72	
		M	0.66	1.14	1.58	1.82	2.37	
		L	0.51	0.86	1.19	1.37	1.8	
	Cooling Pressure Drop	H	7.08	7.48	15.47	11.83	5.53	
		M	5.02	5.8	12.75	8.93	4.33	
		L	3.14	3.5	7.62	5.39	2.64	
	Heating Water Flow Rate	H	Same as cooling water flow rate					
		M	Same as cooling water flow rate					
		L	Same as cooling water flow rate					
	Heating Pressure Drop	H	6.37	6.73	13.92	10.64	4.98	
M		4.52	5.22	11.47	8.04	3.9		
L		2.82	3.15	6.86	4.85	2.38		
Water content		Gal		0.116	0.193	0.272	0.349	0.425

### TESTING CONDITIONS (RATED AT AHRI STANDARD 440):

#### a. Cooling mode (2-pipe/ 4-pipe):

- Return air temperature: DB 80°F/WB 67°F
- Inlet/ outlet water temperature: 45°F/ 55°F

#### b. Heating mode (2-pipe):

- Return air temperature: 70°F
- Inlet water temperature: 140°F
- Water flow-rate: Same as cooling mode

(All dimensions are approximate within 1/16 of an inch of those indicated)

# TECHNICAL SPECIFICATIONS

## Hydronic Slim Console 4 pipe with EC Motor

UNIT GENERAL SPECS	PFWSL-[Size]-P-AECM		01	02	03	04	05
	Configuration		4-pipe				
	Number of Fan Blowers		1			2	
	Power Supply (V/Ph/Hz)		110-120/1/60				
AIR	Total Air Flow	H	106	174	224	271	353
		M	82	144	194	218	294
		L	59	100	135	153	206
COOLING	Total Cooling Capacity	H	2995	5089	6771	8315	10752
		M	2486	4414	6092	6969	9380
		L	1907	3309	4577	5374	7119
	Sensible Cooling Capacity	H	2018	3378	4483	5501	7168
		M	1657	2899	4013	4582	6178
		L	1250	2142	2963	3468	4635
HEATING	Heating Capacity	H	4024	6692	8804	10728	13833
		M	3313	5791	7883	9108	12093
		L	2550	4387	5937	6953	9195
SOUND	Pressure Level	dB(A)	43/37/28	43/38/30	45/43/31	46/42/35	47/43/35
	Power Level		52/46/38	52/47/39	54/52/40	55/51/42	56/52/42
ELECTRICAL	Power Input	H	16	19	22	24	26
		M	13	15	17	18	20
		L	10	11	12	12	12
	Running Current 115V (H)	A	0.28	0.33	0.38	0.42	0.45
Running Current 220V (H)	0.15		0.17	0.2	0.22	0.24	
HYDRONIC	Cooling Water Flow Rate	H	0.59	0.96	1.31	1.55	1.92
		M	0.48	0.77	1.06	1.24	1.52
		L	0.35	0.57	0.76	0.92	1.11
	Cooling Pressure Drop	H	2.98	9.11	6.47	4.74	8.06
		M	2.01	6.12	4.41	3.19	5.29
		L	1.15	3.49	2.44	1.85	2.98
	Heating Water Flow Rate	H	0.2	0.32	0.43	0.51	0.62
		M	0.16	0.26	0.34	0.4	0.5
		L	0.12	0.19	0.25	0.3	0.36
	Heating Pressure Drop	H	0.97	3.05	6.62	1.53	2.57
		M	0.66	2.04	4.43	1.01	1.72
		L	0.37	1.15	2.53	0.6	0.98
Chilled Water Content	Gal	0.06	0.1	0.14	0.18	0.22	
Hot Water Content		0.03	0.05	0.07	0.09	0.11	

### TESTING CONDITIONS (RATED AT AHRI STANDARD 440):

#### a. Cooling mode (2-pipe/ 4-pipe):

- Return air temperature: DB 80°F/WB 67°F
- Inlet/ outlet water temperature: 45°F/ 55°F

#### b. Heating mode (4-pipe):

- Return air temperature: 70°F
- Inlet water temperature: 180°F/140°F

(All dimensions are approximate within 1/16 of an inch of those indicated)

# DIMENSIONAL DRAWINGS, DATA & WEIGHTS

## UNCASED UNIT

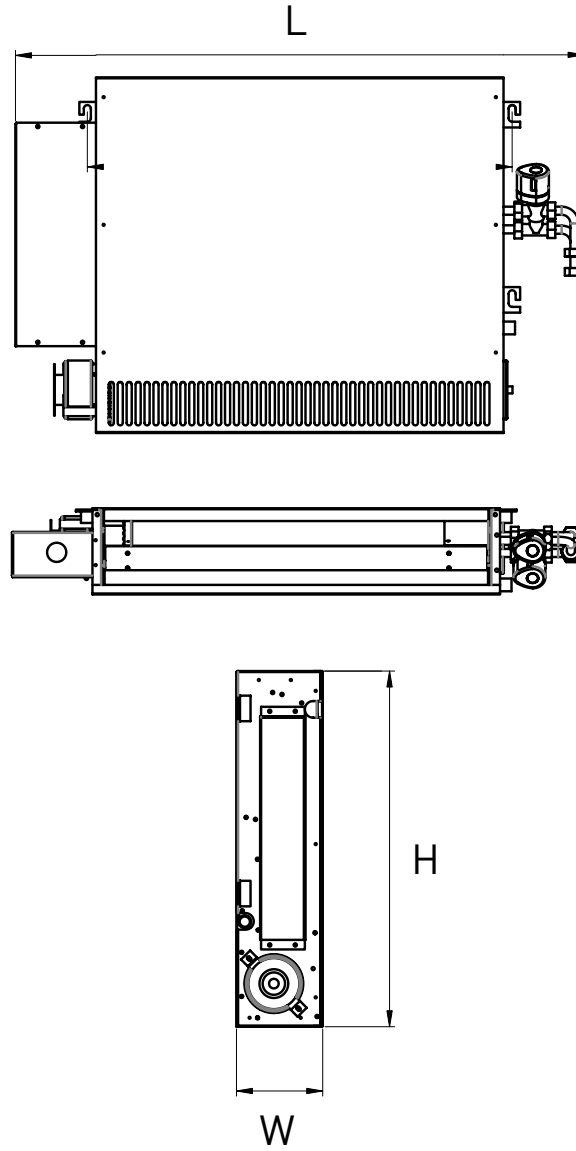

PFWSL			01	02	03	04	05
CONSTRUCTION AND PACKING DATA	Water Connections	Type	FNPT (Threaded Female)				
		In	1/2				
	Out	5/8					
	Condensate Drainage Connection	inch	17.25	25.125	33	40.875	48.75
		Dimensions Uncased Unit	L	5 5/16"			
W			21 11/12"				
WEIGHT	Net Weight	H					
		lbs	41.9	48.5	55.2	61.8	68.4

# DIMENSIONAL DRAWINGS, DATA & WEIGHTS

## CASED UNIT

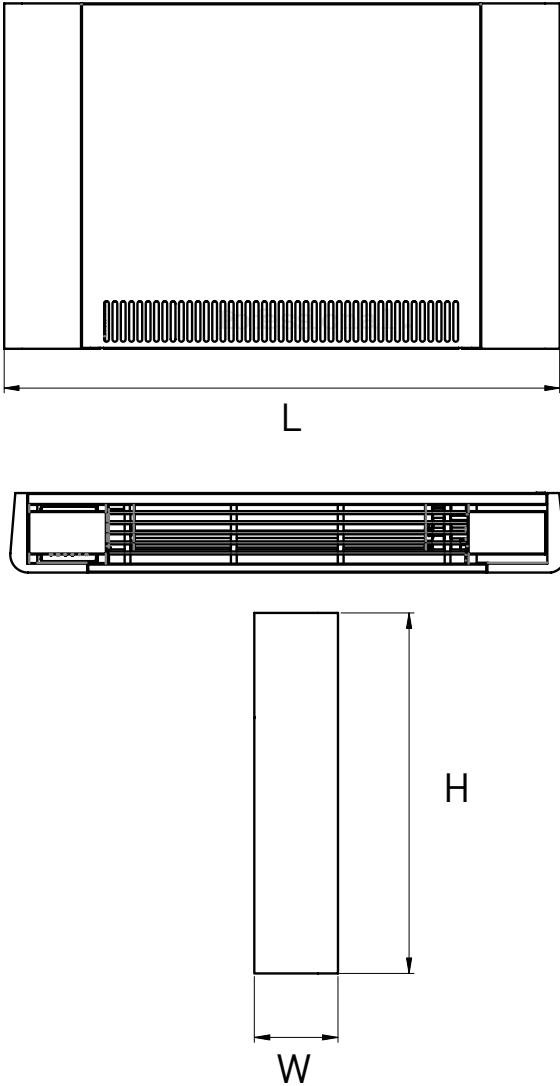

PFWSL			01	02	03	04	05	
CONSTRUCTION AND PACKING DATA	Water Connections	Type	FNPT (Threaded Female)					
		In	1/2					
	Condensate Drainage Connection	Out	5/8					
		inch						
Dimensions Cased Unit	L	inch	28 15/16"	36 13/16"	44 11/16"	52 9/16"	60 7/16"	
			W	5 5/16"				
				H	22 11/12"			
WEIGHT	Net Weight	lbs	41.9	48.5	55.2	61.8	68.4	



# OUR ACCESSORIES



## 01. CONTROLLERS

### [WWP-V3] WIRED WALL PAD CONTROL (AVAILABLE WITH I-CONTROL)

Features: 7 days ON/OFF timer program | Addressable Main and Secondary units allowing control of up to 32 Secondary units via a single Main Unit with set or check of each unit parameters individually | Error display with addressable error diagnostic (Main unit Wall Pad displays Secondary unit address and error type) | One-Touch Global Control (Global Control Main Unit Wall Pad controls all units in the group) | Onboard Room Air Temperature Sensor.



### [IRHS-V1] REMOTE INFRARED HANDSET (AVAILABLE WITH I-CONTROL)

With Global Control functionality for Main and Secondary Unit groups.



## 02. CONTROL OPTIONS

### ABS LED RECEIVER

IR receiver in ABS housing with up to 180cm (70in) length prewiring, which can be connected with TOTAL controls only. LED lights show working mode or error mode.

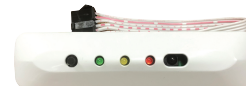

### DIFERENTIAL PRESSURE TRANSDUCER

This device converts the air pressure difference to a proportional electrical output (0-10 VDC/0-5 VDC/4-20 mA). It is suitable for detecting abnormal airflow at the fan coil unit for safety (cutting off electric heater) or maintenance (air filter cleaning) purposes.





### 03. VALVE KITS

#### 2 OR 3 WAY BYPASS THERMOELECTRIC VALVES

2-way or 3-way valve bodies with ON/OFF or modulating actuators integrated with copper piping connection kits.

\* Piping connection kits vary among the different ranges.

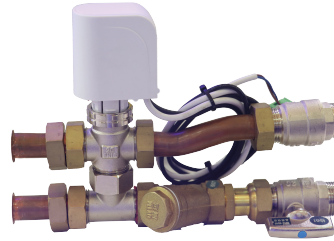

#### 2 OR 3 WAY BYPASS BALL VALVES

2-way or 3-way bypass ball valve bodies with motorized or 24VAC modulating actuators integrated with Copper Piping Connection Kits.

\* Piping connection kits vary among the different ranges.

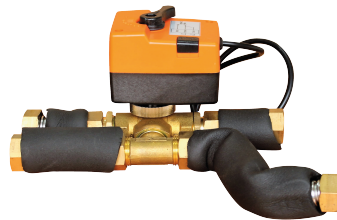

### 04. UPGRADED FILTERS

All our fan coils come with an standard nylon filter installed as standard. If you want an upgrade on those filters, you can choose between:

- **G4 (MERV 8)**  
Available with 3M HAF grade.
- **F8 (MERV 14)**

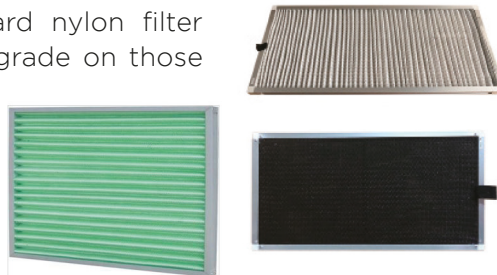

Model	Standard	Optional	
	G2- MERV 4	G4-MERV8	F8-MERV14
PHW	1/8"	-	-
PCGH	1/8"	3/8"	-
PDWA	1/4"	1"	-
PDWC	1/4"	1"	-
PDWSL	1/4"	1/4"	-
PDWD	1"	1"	-
HAHU	1"	1"	2"
VAHU	1"	1"	2"
PFWBC-VAR	1/8"	-	-
PFWBC-HAR	1/4"	1/4"	-
PFWB	1/4"	1/4"	-
PFWSL	1/8"	-	-

## 05. ELECTRIC HEATERS

### PTC ELECTRIC HEATER KIT

With 2-stage safety cut-out and can be configured as booster heaters or primary heaters.

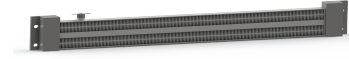

### TUBE ELECTRIC HEATER KIT

With 2-stage safety, cut-outs can be configured as booster heaters or primary heaters. It can be easily installed on-site or in stock via plug-and-play wiring and brackets.

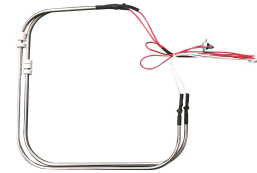

### MODULE ELECTRIC HEATER KIT

The electric heater module is supplied for winter heating as an alternative to the auxiliary hot water coil. We offer a complete range of electric heaters kits, easy to connect to control box, with mounting fixture. The electric heater configuration is selectable by the DIP switch on the internal control board.

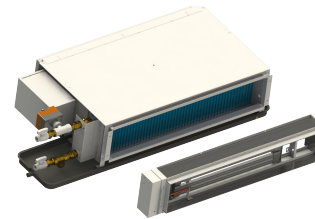

Model	EH KIT (kW)		
	Module	PTC	Tube
PHW	-	0.5 to 1.5	-
PCGH	-	-	0.5 to 4
PDWA	1 to 6	-	-
PDWC	1.5 to 9	-	-
PDWSL	0.75 to 3	-	-
PDWD	3 to 9	-	-
HAHU	4.5 to 9	-	-
VAHU	4.5 to 9	-	-
PFWB(C)	-	0.5 to 3	-
PFWSL	-	0.75 to 1.5	-

\* Non-standard electric heater sizes available under request. Contact us for further information.

## 06. DRAIN PANS

### STAINLESS STEEL DRAIN PAN

To choose between left or right side coil connections.

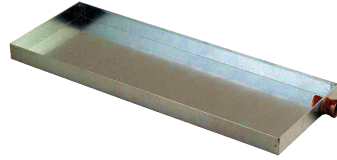

### PAINTED STEEL DRAIN PAN

**For Horizontal installations:** Painted steel drain pans for built-in horizontal floor standing fixed wall installations with right or left-sided coil connections.



**For Vertical installations:** Painted steel drain pans for suspended ceiling installations with right or left-sided coil connections.

Model	ABS Plastic	Powder-coated steel	Stainless Steel
PHW	Standard - Integrated	-	-
PCGH	Standard - Integrated	-	-
PDWA	-	Standard - External	Optional
PDWC	-	Standard - External	Optional
PDWSL	-	Standard - Integrated	Optional
PDWD	-	Standard - Integrated	Optional
HAHU	-	Standard - Integrated	Optional
VAHU	-	Standard - Integrated	Optional
PFWB(C)	-	Standard - Integrated	Optional
PFWSL	-	Standard - Integrated	Optional

## 07. FLANGES

### FLANGES

**For Fresh Air:** Allows up to 15% of unit airflow up to a maximum of 100m<sup>3</sup>/h (59CFM) as fresh air intake (per connection). Cassette comes with knock out fresh air connection holes. ABS plastic flanges use only two screws for fixture to unit. Available for PCGH-3R Cassette range.

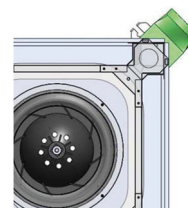

**For Branch Duct:** For delivery of treated air to adjacent spaces with 2 connectors per single fan model. Available for PCGH-3R Cassette ranges.



# Discover polaraircs.com

Download Technical Information &  
Find out more about our Products



# NOTES

A series of horizontal dotted lines for writing notes, with a large light blue speech bubble graphic overlaid in the center.



**NORTH AMERICA**

991 Providence Highway  
Norwood, MA • 02062 • USA  
T (+1) 800 326 9105

**EUROPE**

C/ Rio Jucar, Nave 6. PI El Saladar  
Lorquí • Murcia • Spain • 30564  
T (+34) 968 046 262

**HONG KONG**

Office 6, 9<sup>th</sup> Floor, Block A, 6 On Ping Street  
New Trade Plaza • Shatin, Hong Kong  
T (852) 2648-8887

[www.polaraircs.com](http://www.polaraircs.com) | [contact.polarair@polarglobalgroup.com](mailto:contact.polarair@polarglobalgroup.com)

Note: All the information or data in this catalogue may be changed without previous notice

